



# MATRIX

## SEPARATIONS

### THE PREMIER SOURCE FOR FILTRATION AND SEPARATIONS PRODUCTS

Matrix is a worldwide leader in filtration and separation product innovation focused on high performance and reliability. We offer a complete line of products and equipment, including custom built filters to fit any need.

Plus, we offer 48 hour service on most items. Our products are engineered to deliver the same consistency lot to lot . . . *guaranteed!*

Contact us for any questions about your specific needs, or our products and services, at 423.267.2397.



XLC Filter Cartridges



E-Series Wound Cartridges



Sno-Spun Cartridges

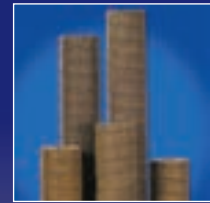

Resin Bonded Filters



Filter Bags



Carbon Cartridge Filters



Filter Vessels



Pleated Cartridges



# Contents



## Cartridge Filters & Bags

XLC Wound Cartridges	1
E-Series Wound Cartridges	3
WTB Melt Blown Cartridges	5
TB Melt Blown Cartridges	7
ATB Melt Blown Cartridges	9
Bi-Component Cartridges	11
Resin Bonded Cartridges	13
Economy Poly-Pleat (Beta 100)	19
High Purity Poly-Pleat (Beta 5000)	20
High Purity Pleated Microfiberglass (Beta 5000)	21
High Purity PES Membrane	22
High Purity Nylon 66 Membrane	23
High Purity Teflon Membrane	24
Pleated Cellulose (Nominal)	25
Pleated Polyester (Nominal)	26
Pleated Polypropylene (Nominal)	27
Carbon Cartridge Filters	29
Filter Bags	31

## Cartridge Filter Housings

Multi-Cartridge Filter Housings	35
Reduced Pressure Model 8 (5 round)	44
Uniflow (Inline Single Cartridge)	46

## Bag Filter Housings

Model 4	48
Model 6	52
Model 8	56

Model NCO and NLCO (Low Cost Non-Code)	61
Model 8 125 Psi (Clamp Cover)	63
Model LCO (Clamp Cover for size 8 & 12 Bags)	65
Model 82 (Dual Capacity)	67
Model 8 (All Plastic PVDF/Polypropylene)	69
Multi-Bag	71

## Specialty Vessels

Multi-Basket Strainers	79
Duplex Bag Filters & Basket Strainers	81
Duplex Bag Filters with Automatic Sequencing	85
Automatic Backwashing Filtration System	88
Multiplex Filters & Strainers	91
Solid/Liquids Separators	93
Portable Filtration System	97
Portable Filter Cart for Coolants & Metalworking Fluids	99

## Appendix

Standard Terms & Conditions	101
Micron Rating For Media in Fluid Filters	103
Glossary of Filtration Terms	105
Application Data Sheet	113
Calculating Total Filter Cost	114
Filtration Request Form (Gas Vessel)	115
Procedure for Gathering Spent Elements for Analysis	117
Equipment Rental Contract	119
Material Selection Guide	123





# *History* of **MATRIX** SEPARATIONS

Matrix Separations has a manufacturing history that goes back over 100 years. Standard Coosa Thatcher (SCT Yarns) was founded in April of 1891 in Piedmont, AL. The first plant in Chattanooga, Tennessee was built in 1912. SCT became a well-known leader of carpet yarns, filtration medias, outerwear yarns, threads, and nonwovens. In 1994, as VP of the Specialty Products Division, Ron Cloud led a buyout of the Filtration Unit thus forming Matrix Separations, LLC. Since Matrix Separations was formed we have transitioned from producing with only mechanical machines to electronically automated modules, provided thermally bonded polypropylene products, and introduced custom built-to-suit string wound elements. Matrix Separations opened our Just-In-Time facility in April of 2006 just outside of downtown Chattanooga. Here we continue to strive to make exceptional products with superior customer service.



First Catoosa Plant - 1891



Matrix Just-In-Time Plant - 2011

# XLC Filter Cartridges

## XLC FILTER CARTRIDGES

The XLC Cartridge (Extended Life Cartridge) is manufactured by a process which uses computer aided designs to construct a true graduated density product that allows unusually extended void volume for greater load capacity, longer life, and higher flow rate. The XLC Cartridge also retains its particle trapping effectiveness up to 99.9%.

## EXTENDED LIFE CARTRIDGE

### BENEFITS

- Dirt holding capacity is more than double that of conventional cartridges.
- Significant cost savings based on decreased production interruptions, less changeouts, inventory, and disposal cost.
- Filter construction can be tailored to fit the specifications of nearly any filtration application by use of computer aided design and intricate computer programming capabilities.
- The XLC cartridge is available in the following materials: Polypropylene Industrial, Polypropylene FDA, Xtrupor, Bleach Cotton, Bleach Cotton FDA, Natural Cotton, Acrylic, Rayon, Polyester, Nylon, and Glass.
- 304SS, 316SS, and Tin steel extended center cores are available as well as a polypropylene snap-in extender.
- Special end treatments such as 222 double O-ring caps, spears, and gaskets are typical additions that enhance cartridge performance.

### RECOMMENDED OPERATING CONDITIONS

- Change out P: 25 psi
- Max Differential P at Ambient Temp: 60 psi
- Standard Dimensions
- 1 inch Inside Diameter
- 2.5 inch Outside Diameter
- 4-50 inch Length

This is to be used as a general reference only. The supplier assumes no responsibility or liability for the accuracy or completeness or results obtained by the use of this information. Users are advised to make their own test to determine the safety and suitability of each product or product combination.



### TYPICAL APPLICATIONS

- Chemical Connectors
- Consumer Products
- Food and Beverage
- Oil
- Paint, Ink
- Petro Chemical
- Pharmaceutical
- Photograph
- Plating
- Printed Circuit
- Printed Wire
- Surface
- Utilities
- Waste Management

# XLC FILTER CARTRIDGES

## SELECTION GUIDE

A Grade	X Cartridge Code	P Type	5 Micron Rating	A Cartridge Diameter	10 Length in Inches		P Core	*C Covers	D End Cap Code	S O-Rings /Gaskets
A=Absolute Density with End Treatments (Optional)	X=XLC Graduated Density	P=Polypropylene	0.5	T=1 1/2"	4	5	P=PP	*C=Compatible	A= DOE W/gasket - no caps	B=Buna E=EPDM S=Silicone V=Viton T=Teflon Encapsulated Viton
		PP=Polypropylene FDA	1	R=1 3/4"	6	9.8	A=304SS	*E=Polyester	B= DOE W/gasket - and cap	
		PX=Xtrupor	3	B=2"	10	12	S=316SS	*M=Membrane	C= 222 W/Spear	
		C=Bleach Cotton	5	F=2 3/8"	12.5	19.5	C=1.56 Steel	*G=Glass	D= 222 W/Closed Flat Cap	
		CC=Bleach Cotton FDA	10	A=2 1/2"	20	27	D=1.22 PP		E= 222 W/Spring	
		CN=Natural Cotton	20	S=2 5/8"	29.3	29.5	F=Glass PP		F= 226 W/Closed Flat Cap	
		R=Rayon	25	C=2 11/16"	30	36	M=1.56 PP		G= 226 W/Spear	
		A=Acrylic	30	D=2 3/4"	38	39	W=PP/HW		H= 226 W/Spring	
		PE=Polyester	50	E=3"	40	50	T=EPT		J= Polypropylene Extender	
		N=Nylon	75	H=3 1/8"					K= Crimped Extended Core	
		G=Glass	100	J=3 1/2"					L= Spring	
			200	M=4"					M= 316 Metal Extender	
			250	W=4 1/4"					IB=IND. Bag	
			400	N=4 1/2"					IBL= IND. Bag & Label	
		U=2 1/4"								

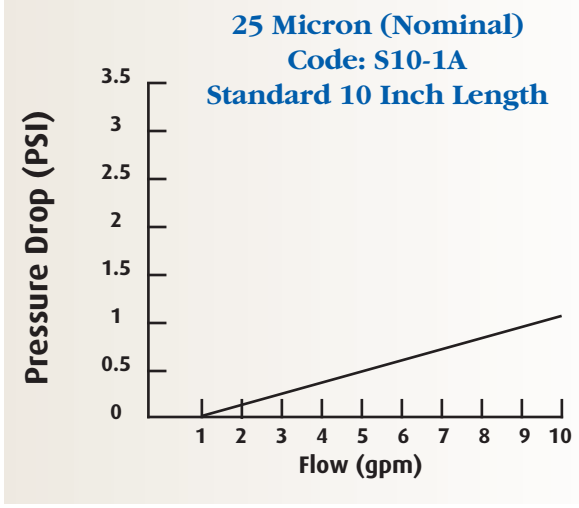
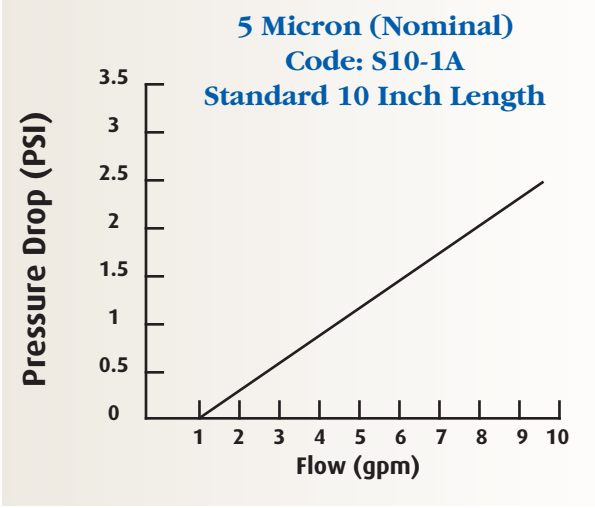
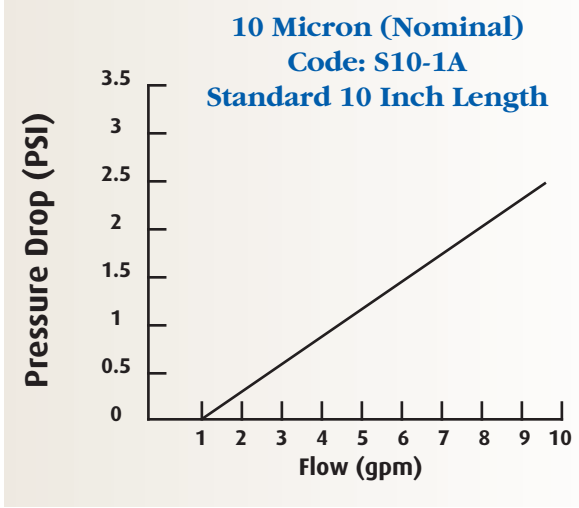
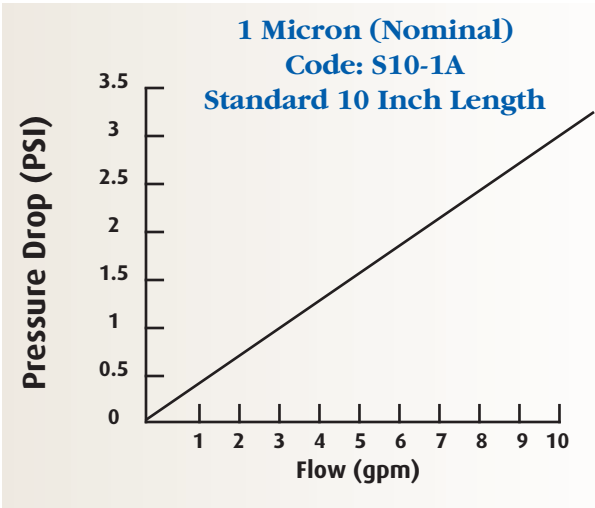

Test Fluid: Water at Ambient Temperature • Flow is in US Gallons per minute.



# E-Series Wound Depth Cartridges

## E-SERIES WOUND DEPTH CARTRIDGES

Matrix has become a world leader in the filter cartridge market with the E-Series. We precisely pattern fibers to create consistently reliable filtration with a trapping effectiveness of up to 99%.

Matrix wound cartridges offer a gradual pressure increase during cartridge life instead of the abrupt flow cutoff experienced with competitor's cartridges.

Customer service representatives are available for custom cartridge construction requests.

Matrix XLC cartridges are available in both nominal and absolute ratings.

### **BENEFITS**

- Offered in a wide variety of lengths from 4in. to 50in., and diameters from 1.5in. to 4.5in. OD for easy vessel fittings.
- The E-Series cartridge is available in the following media:  
**Polypropylene Industrial, Polypropylene FDA, Xtrapor, Bleach Cotton, Bleach Cotton FDA, Natural Cotton, Acrylic, Rayon, Polyester, Nylon, and Glass.**
- Core Covers offered in cotton, polypropylene, polyester, paper, glass, and membrane for excellent fiber migration protection.
- 304SS, 316SS, and Tin steel extended center cores are available, as well as, a polypropylene snap-in extender.
- Special end treatments such as 222 double O-ring caps, spears, and gaskets are typical additions that enhance cartridge performance.

### **RECOMMENDED OPERATING CONDITIONS**

- Change out P: 25 psi
- Max Differential P at Ambient Temp: 60 psi
- Standard Dimensions
- 1 inch Inside Diameter
- 2.5 inch Outside Diameter
- 4-50 inch Length

This is to be used as a general reference only. The supplier assumes no responsibility or liability for the accuracy or completeness or results obtained by the use of this information. Users are advised to make their own test to determine the safety and suitability of each product or product combination.



### **TYPICAL APPLICATIONS**

- Chemicals
- Connectors
- Consumer Products
- Food and Beverage
- Oils
- Paint Ink
- Petro Chemical
- Pharmaceutical
- Photographic
- Plating
- Vegetable Oils
- Water
- Waste Treatment

### **Expanded Void Volume Enhances Filtration**

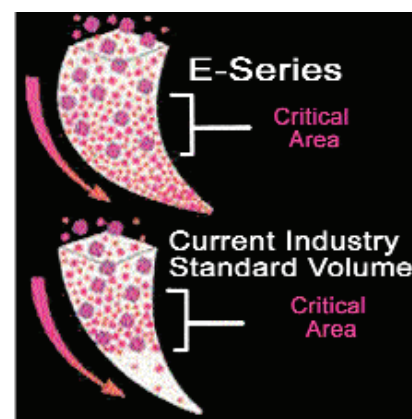

**E-SERIES WOUND DEPTH CARTRIDGES**

**SELECTION GUIDE**

A Grade	P Type	5 Micron Rating	A Cartridge Diameter	10 Length in Inches	P Core	*C Covers	D End Cap Code	S O-Rings /Gaskets	
A=Absolute	P=Polypropylene	0.5	T=1 1/2"	4	5	P=PP	*C=Compatible	A = DOE W/Gaskets No Caps	B=Buna
Blank=Nominal	PP=Polypropylene FDA	1	R=1 3/4"	6	9.8	A=304SS	*E=Polyester	B = DOE W/Gaskets And Caps	E=EPDM
	PX=Xtrupor	3	B=2"	10	12	S=316SS	*M=Membrane	C = 222 W/Spear	S=Silicone
	C=Bleach Cotton	5	F=2 3/8"	12.5	19.5	C=1.56 Steel	*G=Glass	D = 222 W/Closed Flat Cap	V=Viton
	CC=Bleach Cotton FDA	10	A=2 1/2"	20	27	D=1.22 PP		E = 222 W/Spring	T=Teflon Encapsulated Viton
	CN=Natural Cotton	20	S=2 5/8"	29.3	29.5	F=Glass PP		F = 226 W/Closed Flat Cap	
	R=Rayon	25	C=2 11/16"	30	36	M=1.56 PP		G = 226 W/Spear	
	A=Acrylic	30	D=2 3/4"	38	39	W=PP/HW		H = 226 W/Spring	
	PE=Polyester	50	E=3"	40	50	T=EPT		J = Polypropylene Extender	
	N=Nylon	75	H=3 1/8"					K = Crimped Extended Core	
	G=Glass	100	J=3 1/2"					L = Spring	
		200	M=4"					M = 316 Metal Extender	
		250	W=4 1/4"					IB = IND BAG	
		400	N=4 1/2"					IBL = IND BAG & LAB	
			U=2 1/4"						

**Matrix has become a world leader in the filter cartridge market with the E-Series.**

**Pressure Drop vs. Flow Rate**

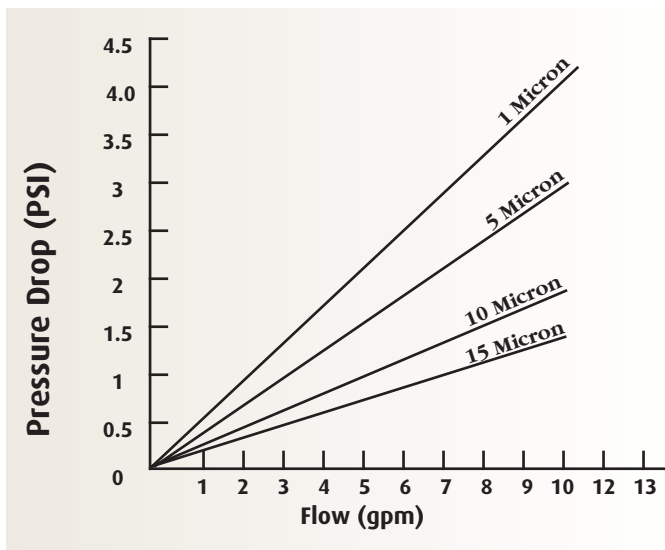

## WTB SNO-SPUN

## SNO-SPUN

Matrix SNO-SPUN filter cartridges are made of polypropylene resin meeting FDA regulation 21CFR177.1520. No binders, lubricants or antistatic agents are used in our manufacturing process. Matrix SNO-SPUN polypropylene filters have been tested and certified under ANSI/NSF standard 42 for material requirements only. The inert polypropylene resin provides exceptional chemical compatibility to handle a wide range of process fluids.

Matrix cartridges are designed to provide high flow rates with minimum pressure drop. Flow rates of up to 5 gpm per 10" length are recommended and should not exceed 10 gpm per 10" length for optimal efficiency. The maximum operating temperature is 160 F (70 C).



### BENEFITS

- WTB Series offers an excellent option for general applications anytime long life and value is required
- Polypropylene construction provides broad chemical compatibility for many applications.
- Single length construction simplifies compatibility options and provides easy disposal.
- Continuous fiber matrix prevents media migration.
- Finish-free construction provides optimum fluid purity and eliminates foaming condition.

### TYPICAL APPLICATIONS

- Chemicals
- Process Water
- Pharmaceuticals
- Plating Solutions
- RO Prefilters
- Waste Effluent
- Water

**WTB**  
Removal Efficiency of SNO-SPUN  
5 Micron Filter

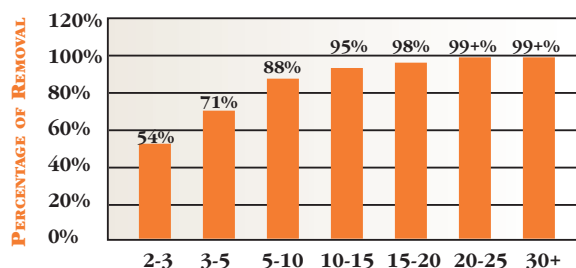

This is to be used as a general reference only. The supplier assumes no responsibility or liability for the accuracy or completeness or results obtained by the use of this information. Users are advised to make their own test to determine the safety and suitability of each product or product combination.



**SNO-SPUN**

**SELECTION GUIDE**

WTB Cartridge Code	5 Micron Rating	A Cartridge Diameter	10 Length in Inches	D End Cap Code	S O-Rings /Gaskets
WTB = Economy	.5	A = 2 1/2"	4	A = DOE W/Gaskets No Cap	B = Buna
	1	E = 3"	5	B = DOE W/Gaskets And Cap	E = EPDM
	3	N=4 1/2"	6	C = 222 W/Spear	S = Silicone
	5		9.8	D = 222 W/Closed Flat Cap	V = Viton
	10		10	E = 222 W/Spring	T = Teflon Encapsulated Viton
	20		12	F = 226 W/Closed Flat Cap	
	25		12.5	G = 226 W/Spear	
	50		19.5	H = 226 W/Spring	
	75		20	J = Polypropylene Extender	
	100		27	K = Crimped Extended Core	
	150		29.3	L = Spring	
			29.5	M = 316 Metal Extender	
			30	IBL = Ind. Bag & Label	
			36		
			38		
		39			
		40			
		50			

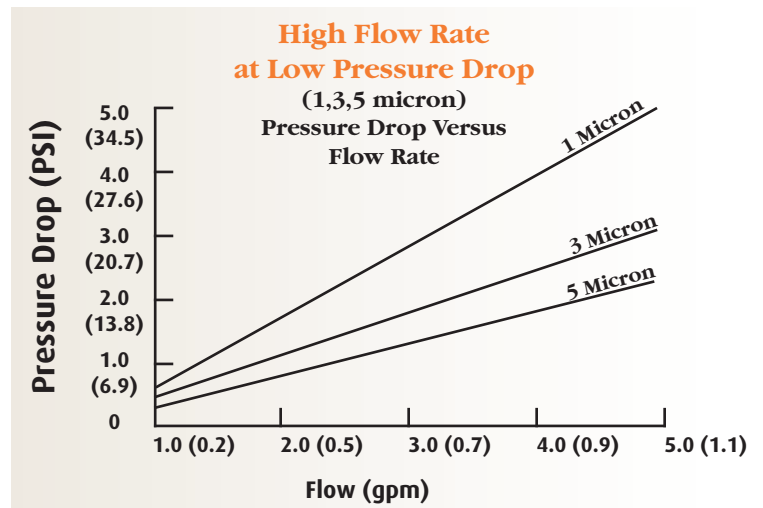
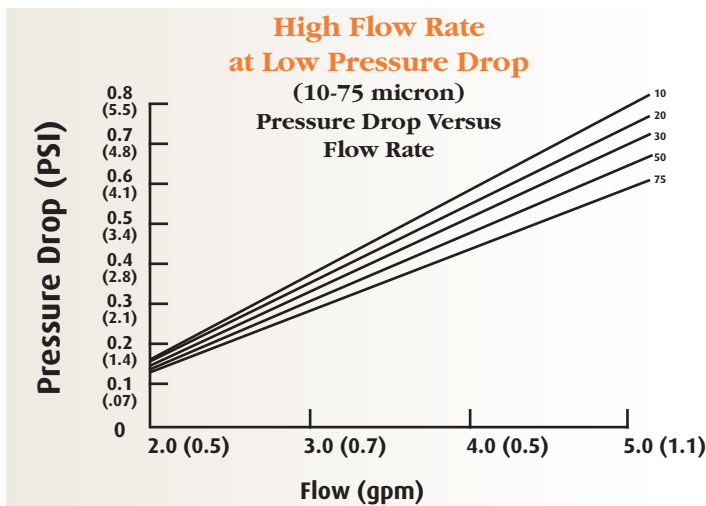

## TB SNO-SPUN

## SNO-SPUN

Matrix SNO-SPUN filter cartridges are made of polypropylene resin meeting FDA regulation 21CFR177.1520. No binders, lubricants or antistatic agents are used in our manufacturing process. Matrix SNO-SPUN polypropylene filters have been tested and certified under ANSI/NSF standard 42 for material requirements only. The inert polypropylene resin provides exceptional chemical compatibility to handle a wide range of process fluids.

Matrix cartridges are designed to provide high flow rates with minimum pressure drop. Flow rates of up to 5 gpm per 10" length are recommended and should not exceed 10 gpm per 10" length for optimal efficiency. The maximum operating temperature is 160 F (70 C).



### BENEFITS

- TB Series offers a combination of efficiency, affordability, purity, and extended life forming a high performance depth cartridge.
- Polypropylene construction provides broad chemical compatibility for many applications.
- Continuous fiber matrix prevents media migration.
- Graduated density provides twice the life of other manufactures.
- Fixed pore structure provides optimum particle retention.
- Finish-free construction provides optimum fluid purity and eliminates foaming condition.

This is to be used as a general reference only. The supplier assumes no responsibility or liability for the accuracy or completeness or results obtained by the use of this information. Users are advised to make their own test to determine the safety and suitability of each product or product combination.

### TYPICAL APPLICATIONS

- Aerosol Products
- Bottled Water
- Chemicals
- Food and Beverage
- Oil and Gas
- Pharmaceuticals
- Photographic
- Plating Solutions

#### TB

Removal Efficiency of SNO-SPUN 5 Micron Filter

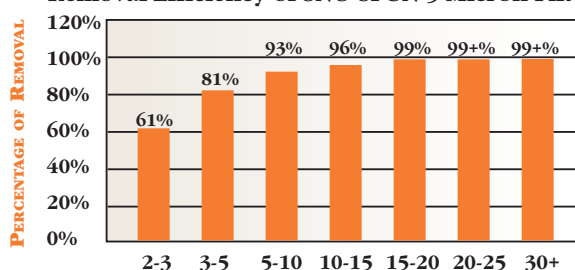

#### TBG

Removal Efficiency of SNO-SPUN 5 Micron Filter

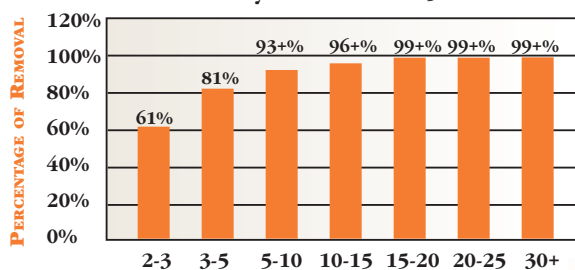

**MATRIX**  
SEPARATIONS

# SNO-SPUN

TB Cartridge Code	5 Micron Rating	A Cartridge Diameter	10 Length in Inches	P Core	D End Cap Code	S O-Rings /Gaskets
TB = Industrial	.5	A = 2 1/2"	4	P = PP	A = DOE w/Gaskets No Cap	B = Buna
TBG = Industrial Grooved	1	E = 3"	5	Blank = No Core	B = DOE W/Gaskets and Cap	E = EPDM
	3	N=4 1/2"	6		C = 222 W/Spear	S = Silicone
	5		9.8		D = 222 W/Closed Flat Cap	V = Viton
	10		10		E = 222 W/Spring	T = Teflon Encapsulated Viton
	20		12		F = 226 W/Closed Flat Cap	
	25		12.5		G = 226 W/Spear	
	50		19.5		H = 226 W/Spring	
	75		20		J = Polypropylene Extender	
	100		27		K = Crimped Extended Core	
	150		29.3		L = Spring	
			29.5		M = 316 Metal Extender	
			30		IBL = Ind. Bag & Label	
			36			
			38			
			39			
			40			
			50			

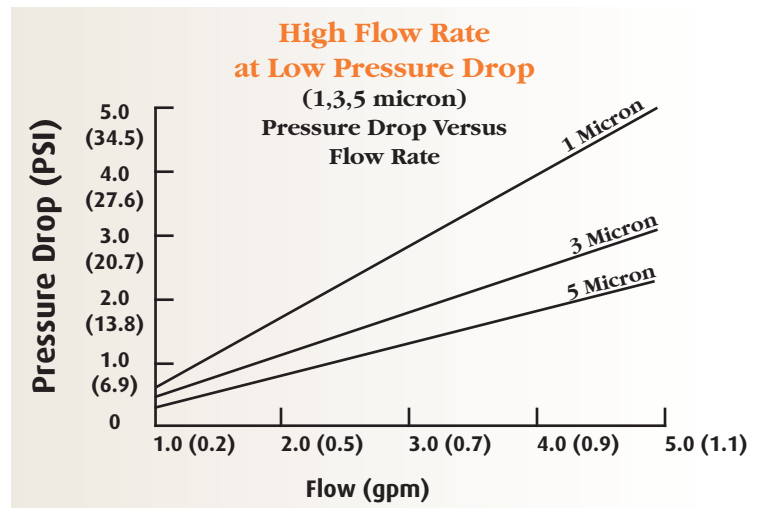
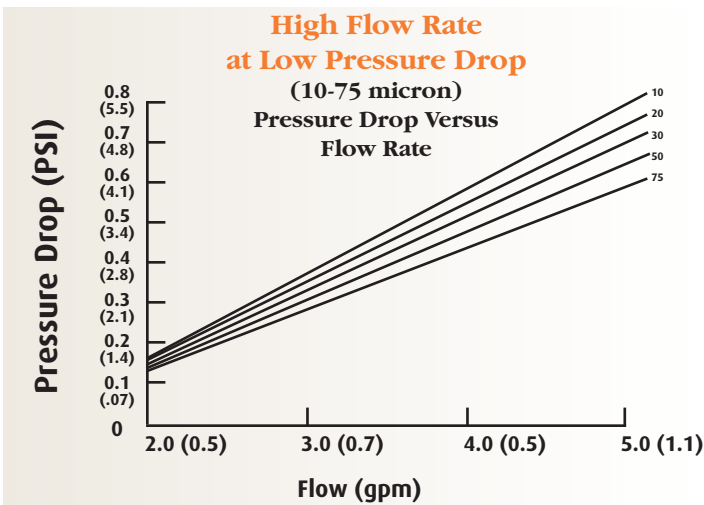

## ATB SNO-SPUN

## SNO-SPUN

Matrix SNO-SPUN filter cartridges are made of polypropylene resin meeting FDA regulation 21CFR177.1520. No binders, lubricants or antistatic agents are used in our manufacturing process. Matrix SNO-SPUN polypropylene filters have been tested and certified under ANSI/NSF standard 42 for material requirements only. The inert polypropylene resin provides exceptional chemical compatibility to handle a wide range of process fluids.

Matrix cartridges are designed to provide high flow rates with minimum pressure drop. Flow rates of up to 5 gpm per 10" length are recommended and should not exceed 10 gpm per 10" length for optimal efficiency. The maximum operating temperature is 160 F (70 C).



### BENEFITS

- ATB Series offers high particle retention which equals the performance of most other absolute rated cartridges.
- Polypropylene construction provides broad chemical compatibility for many applications.
- Continuous fiber matrix prevents media migration.
- Graduated density provides twice the life of other manufactures.
- Superior inner-layer bonding eliminates containment, unloading, and channeling.
- Finish-free construction provides optimum fluid purity and eliminates foaming condition.

### TYPICAL APPLICATIONS

- Aerosol Products
- Chemicals
- Food and Beverage
- Oil and Gas
- Pharmaceuticals
- Photographic
- Plating Solutions
- Process Water
- Pure Water

**ATB**  
Removal Efficiency of SNO-SPUN  
5 Micron Filter

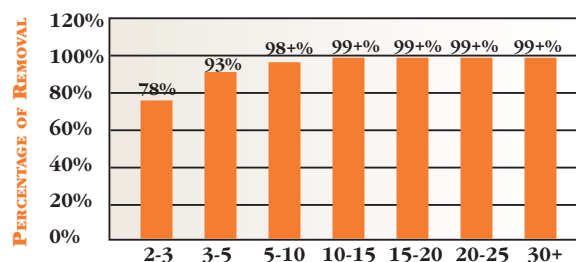

This is to be used as a general reference only. The supplier assumes no responsibility or liability for the accuracy or completeness or results obtained by the use of this information. Users are advised to make their own test to determine the safety and suitability of each product or product combination.

# SNO-SPUN

ATB Cartridge Code	5 Micron Rating	A Cartridge Diameter	10 Length in Inches	P Core	D End Cap Code	S O-Rings /Gaskets
ATB = Absolute	1	A = 2 1/2"	4	P = PP	A = DOE W/Gaskets No Cap	B = Buna
ATBG = Absolute Grooved	3	E = 3"	5	Blank = No Core	B = DOE W/Gaskets And Cap	E = EPDM
	5	N=4 1/2"	6		C = 222 W/Spear	S = Silicone
	10		9.8		D = 222 W/Closed Flat Cap	V = Viton
	20		10		E = 222 W/Spring	T = Teflon Encapsulated Viton
	25		12		F = 226 W/Closed Flat Cap	
	50		12.5		G = 226 W/Spear	
	75		19.5		H = 226 W/Spring	
	100		20		J = Polypropylene Extender	
	150		27		K = Crimped Extended Core	
			29.3		L = Spring	
			29.5		M = 316 Metal Extender	
			30		IBL = Ind. Bag & Label	
			36			
			38			
			39			
			40			
			50			

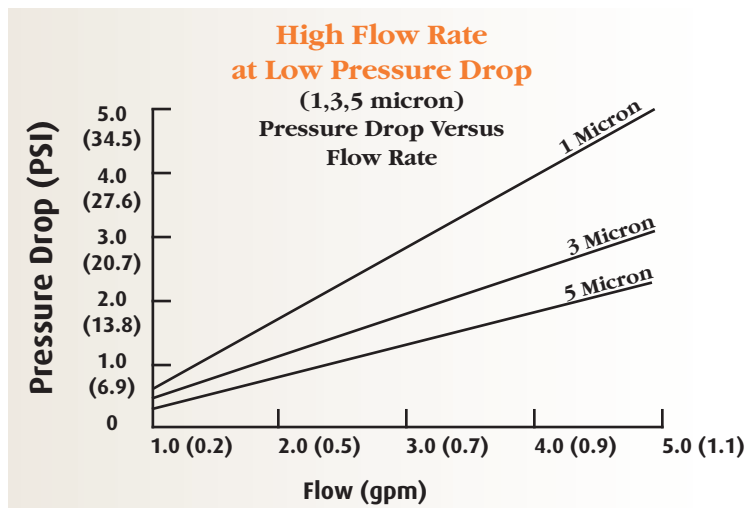
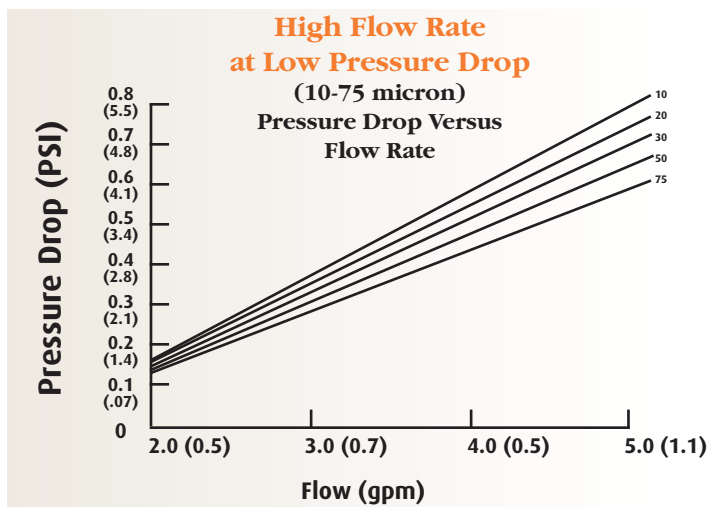

# Bi-Component Filter Cartridge

## BI-COMPONENT FILTER CARTRIDGE

### Self-Bonding, Binder-Free, Polyolefin Filter Cartridge

Only polyolefin thermally bonded bi-component fibers are used in the construction of the Matrix Bi-Component Filter Cartridges. The unique fiber-to-fiber bond forms a very stable porosity. The patented construction of the Bi-Component filter cartridge provides consistent filtration and eliminates pore size variability and media migration.

The rigid construction also provides a three dimensional fiber network that offers a high tolerance to differential pressures. This unique feature also prevents changes in the fiber matrix throughout the life of the filter providing for precise filtration and eliminating filter unloading.



### CONSTRUCTION MATERIALS

<b>Filtration Media</b> .....	Polyolefin
<b>End Caps</b> .....	Polypropylene
<b>O-rings/Gaskets</b> .....	Buna, EPDM, Silicon Viton, Polyfoam

### ORDERING INFORMATION GPB SERIES – POLYOLEFIN BICOMPONENT CARTRIDGES

(Replaces Cuno Betapure AU part numbers)

Examples of Part numbers:

**GP85-9.75 GPB25-10-2P GPB75-40-3E**

### DIMENSIONS (NOMINAL)

**LENGTHS:** 9.75 to 40 inches (24.8 to 102 cm)

**OUTSIDE DIAMETER:** 2.6 inches (6.6 cm)

**INSIDE DIAMETER:** 1.1 inch (2.8 cm)

### MAXIMUM RECOMMENDED OPERATING CONDITIONS

**DIFFERENTIAL PRESSURE** .....  $\Delta$  P-80 PSI

**TEMPERATURE** ..... 175°F (80°C)

### DIMENSIONS (NOMINAL)

Manufactured from materials, which are listed for food contact applications in Title 21 of the U.S. Code

GPB	Nominal Micron	—	(Length)	—	(End Cap Code)	O-Rings/Gaskets
Polyolefin	1	(Cuno "A")	9.75		Blank = None	Blank = None
	3	(Cuno "B")	10		A = DOE Poly Gaskets	B = Buna
	5	(Cuno "C")	19.5		C = 222 W/Spear	E = EPDM
	10	(Cuno "E")	20.5		D = 222 W/ Closed Flat Cap	S = Silicone
	25	(Cuno "G")	29.25		E = 222 W/Spring	V = Viton
	50	(Cuno "L")	30		F = 226 W/Closed Flat Cap	P = Polyfoam
	75	(Cuno "Q")	39		G = 226 W/Spear	
	100	(Cuno "V")	40		H = 226 W/Spring	
	150	(Cuno "W")			J = Polypropylene Core Extender	
	200				L = W/Spring	
	350					

# BI-COMPONENT FILTER CARTRIDGE



## Performance Data

### Flow versus Pressure

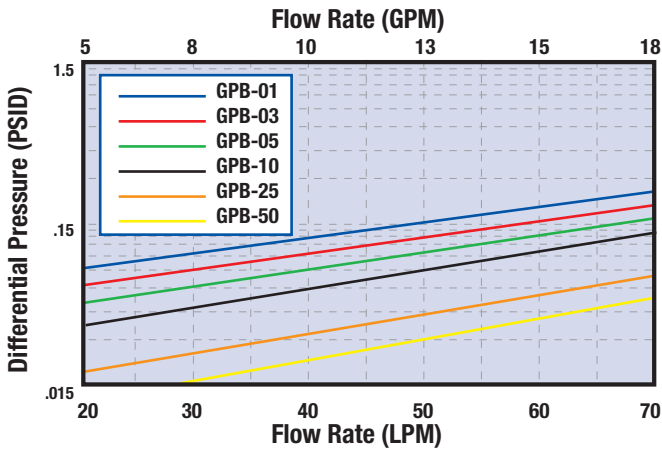

### Filtration Efficiencies

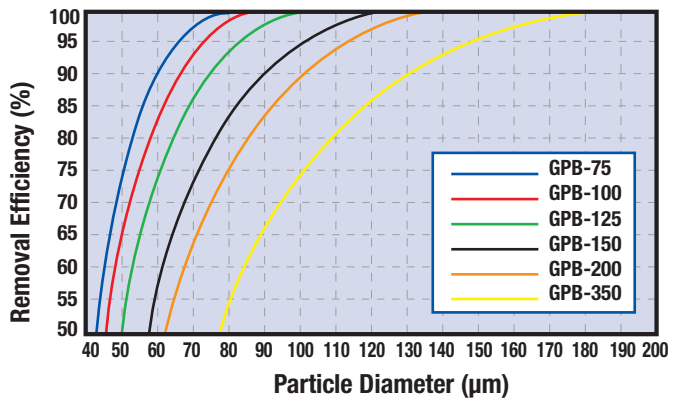
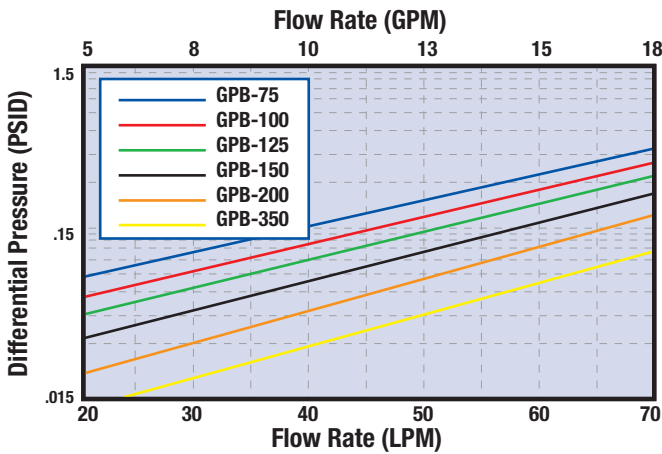
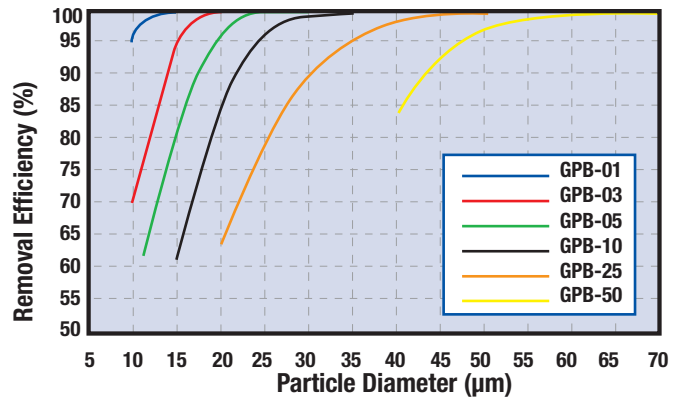

# Resin Bonded Filters

## RESIN BONDED FILTERS

Economical Depth Filtration at higher flow rates and higher viscosities. Matrix cartridges have a two-stage filtration design to maximize particle removal and service life in viscous fluid filtration applications.

Matrix cartridges are available in several different micron ratings including 2, 3, 5, 10, 25, 50, 75, 100, 125, and 150 to meet a wide variety of performance requirements.

### **BENEFITS**

The unique wrapping of continuous fiberglass media with a formulated phenolic resin makes it possible to provide:

- True gradient density
- Consistent particle removal efficiencies
- Extended cartridge life
- PH range from 4 to 10 in most applications
- Extensive chemical compatibility
- Extra long acrylic/polyester fibers provide added strength and resist breakage.
  - Wide range of effective applications
  - Provided in a choice of four styles:
    - RBP-Plain Cylindrical Surface
    - RBG-Grooved for increased surface area.
    - RBGC-Grooved/Economical Grade.
    - RBW-Grooved for food and water applications.
- Silicone free construction ensures no contamination to adversely affect adhesion properties of coatings.
- Outer layers collect large particles, while inner layers control particle removal at rated size.
- Available with optional end treatments.
- Withstands pressure surges up to 125 psi across cartridge.
- Phenolic resin impregnation strengthens cartridge for use with fluid viscosities up to 15000 SSU.



RBGC Series

### **TYPICAL APPLICATIONS**

- Abrasives
- Adhesives
- Animal Oils
- Chemical Coatings
- Emulsions
- Organic Fluids
- Organic Solvents
- Paints
- Petroleum
- Plasticizers
- Printing Inks
- Process Water
- Resins
- Waxes

### **RECOMMENDED OPERATING CONDITIONS**

Max Temp - RBW = 140° F  
 RBGC = 250°  
 RBG = 200°  
 RBP = 200°

Change out P:50 psi (3.5bar)



## RESIN BONDED FILTERS

### SELECTION GUIDE

RBG TYPE	50 MICRON RATING	A CARTRIDGE DIAMETER	98 LENGTH IN DIAMETER	END CAP / CORE OPTIONS L
RBP=Plain	1 RBP, RBG, RBW	A = Standard	98=9.75"	J = Polypropylene Extender
RBG=Grooved	2 RBGC		10=10"	L = Spring
RBGC=Grooved/ Economical Grade	3 RBP, RBG, RBW		19.5=19.5"	T = Tin Core
RBW=Melamine	5 ALL		20=20"	
	10 ALL		29=29"	
	25 ALL		29.3=29.25"	
	50 ALL		29.5=29.5"	
	10 ALL		30=30"	
	25 ALL		39=39"	
	50 ALL		40=40"	
	75 ALL			
	100 RBP, RBG, RBW			
	125 ALL			
	150 ALL			

### Standard Dimensions

2 5/8" Outside Diameter(67mm) • 1.06" Inside Diameter (29.6mm) for RBP, RBG, & RBW Products.

2 1/2" Outside Diameter • 1.06" Inside Diameter RBGC Products.

## Resin Bonded Flow Properties

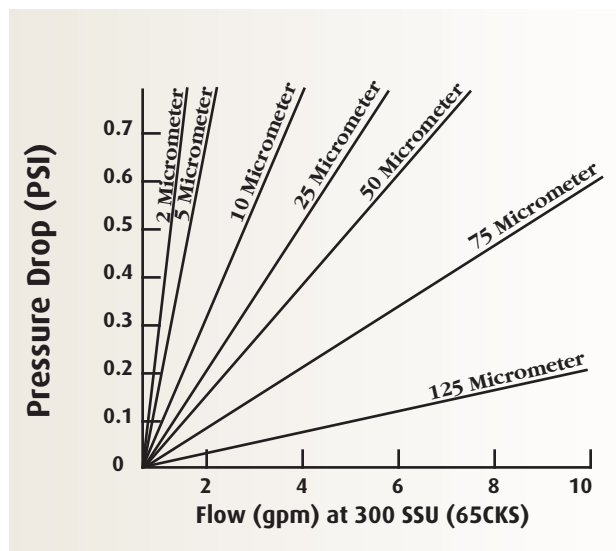

## Fiberglass Resin-Bonded Filter Cartridge

**RESIN BONDED  
FILTERS**

Matrix's Fiberglass Resin-Bonded Filter Cartridges offer proven performance in high temperature and high pressure applications.



### Typical Applications

Solvents	Varnishes
Paints	Coolants
Inks	Fuels and Lube Oils

**Note:** The filtration of industrial or potable water is not recommended with this cartridge.

### Standard Dimensions (nominal)

#### Lengths:

9.75 to 60 inches (24.8 to 153 cm)

#### Outside Diameter:

2.6 inches (6.6 cm)

#### Inside Diameter:

1.1 inch (2.8 cm)

### Construction Materials

Filtration Media .....	Microfiberglass
Binder .....	Phenolic Resin
Core .....	Tin or Stainless

### Maximum Recommended Operating Conditions

Differential Pressure .....	$\Delta P$ -80 PSI
Temperature .....	360° F (200° C)

### Ordering Information

GFR	MICRON	GROOVING	LENGTH	COVER	VAIL	CORE
	1	U = Ungrooved	9.75	N = None	N = None	N = None
	5	G = Grooved	10	C = Cotton	V = Core Vail	T = Tin
	10		19.5			HT = Heavy Tin
	25		20			S = Stainless
	50		29.25			P = Polypropylene
	75		30			
	100		39			
	125		40			
	150					

### Performance Data

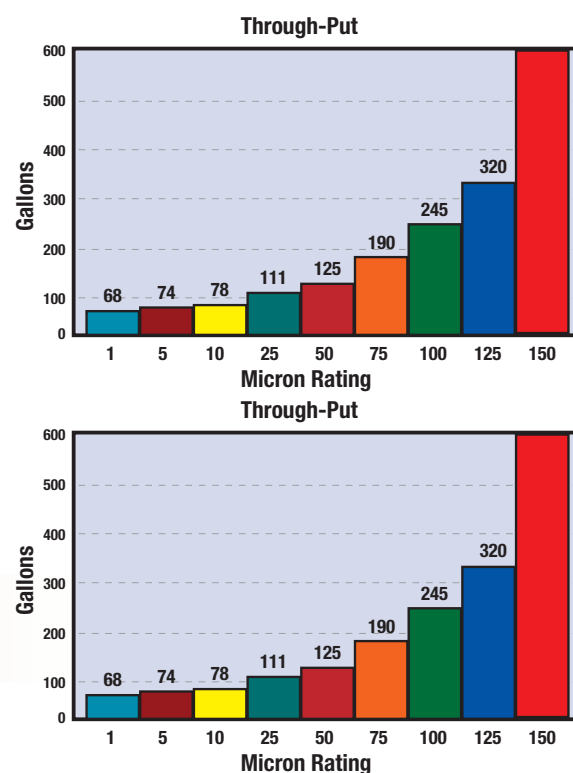

Average Test Data to 30 psi  $\Delta P$ , using A.C. Course Dust in Water. At a constant flow rate of 3 GPM.

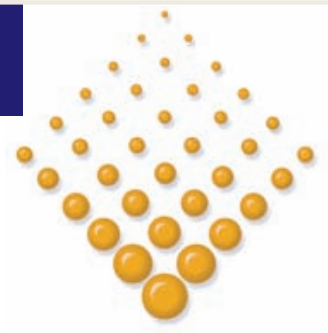

**MATRIX**  
SEPARATIONS



## Pleated Cartridges

Matrix pleated cartridges feature the latest technology in filter media and constructions. Layers of cellulose, polyester, polypropylene and glass are typical depth medias. Membranes are provided in polypropylene, polyethersulfone, teflon, and nylon.

### TYPICAL APPLICATIONS

- Food and Beverage
- Bottled Water
- Membrane Pre-Filter
- Fine Chemicals
- Electronics
- Water Purification
- Cosmetics
- Process Water
- Pharmaceuticals
- Catalyst Recovery

Matrix offers a nominal economy series, as well as, a high efficiency product. Contact our customer service representatives with any questions.



This is to be used as a general reference only. The supplier assumes no responsibility or liability for the accuracy or completeness or results obtained by the use of this information. Users are advised to make their own test to determine the safety and suitability of each product or product combination.

## PLEATED CARTRIDGES

### Economy Poly-Pleat Polypropylene Pleated Depth Cartridges

Matrix's CPP/CPW all Polypropylene Filter Cartridges are designed to optimize throughout while achieving absolute and repeatable effluent quality. Our filter media is constructed on the latest continuous Micro-Fiber blowing equipment that accurately controls fiber diameter and integrity. Utilizing state-of-the-art on-line monitoring equipment. Matrix delivers the industry's most uniform and consistent media, ensuring unparalleled product consistency. Our 100% Polypropylene construction provides an expansive chemical compatibility range for your most demanding applications.

## PRODUCT SPECIFICATIONS

### MATERIALS OF CONSTRUCTION

<b>Filter Media:</b>	Polypropylene Microfiber
<b>Support Material:</b>	Polypropylene
<b>Hardware:</b>	Polypropylene
<b>Cage:</b>	Polypropylene
<b>Sealing:</b>	Thermal Bond
<b>O-rings:</b>	Buna N, Viton A, EPDM Teflon Encapsulated Viton

### DIMENSIONS

#### Outside Diameter:

2.55" (6.48 cm)

#### Lengths:

10" (25.4cm), 20" (50.8cm),  
30" (76.2cm), 40" (102cm)

### MAXIMUM OPERATING TEMPERATURE

180° F (82° C) Continuous Duty

### PERFORMANCE SPECIFICATIONS

Retention Rating: 0.2, 0.5, 1.0, 2.5, 5.0, 10, 15, 20, 40, 70

### PACKAGING ECONOMY

Bulk packaging in case quantities to reduce material disposal:

10 inch	24 per carton
20 inch	12 per carton
30 inch	12 per carton
40 inch	9 per carton

This is to be used as a general reference only. The supplier assumes no responsibility or liability for the accuracy or completeness or results obtained by the use of this information. Users are advised to make their own test to determine the safety and suitability of each product or product combination.

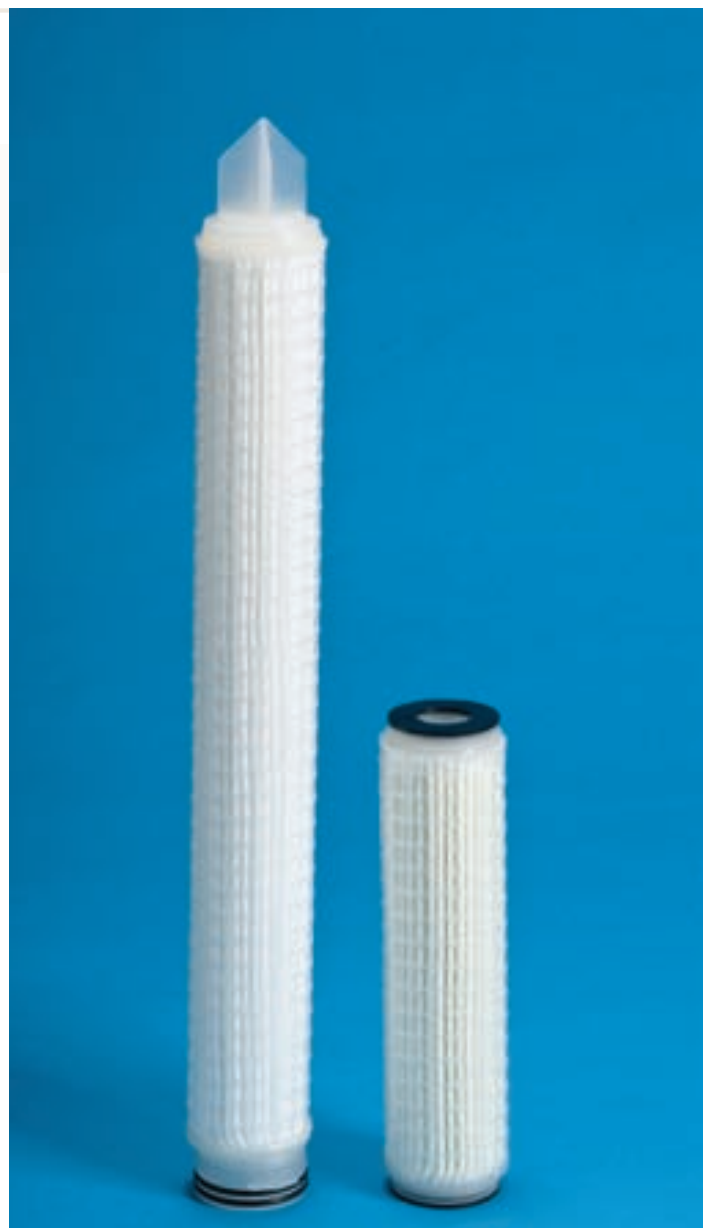

### BENEFITS

- Absolute-rated media provides reliable, consistent and repeatable filtration
- Low pressure drop yields higher flow rates and reduced processing time
- MAXX-imum pleat design for greater surface area, ensuring longer service life, less downtime and reduced operating costs per cartridge
- 100% Polypropylene, FDA compliant with CFR 21
- Thermally bonded construction, eliminating particle bypass
- CPP elements have over 6 sq. ft. of surface area per 10" equivalent
- CPW elements have 4.5 sq. ft. of surface area per 10" equivalent



# Economy Poly-Pleat

## Polypropylene Pleated Depth Cartridges

**PLEATED  
CARTRIDGES**

### PRESSURE DROP VS. FLOW RATE

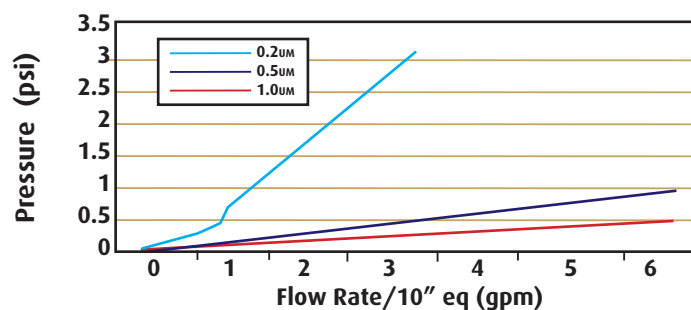
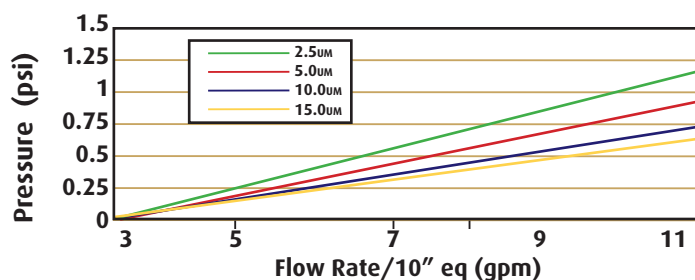

### PRODUCT EFFICIENCY

POLY-PLEAT	BETA 100
CPP/CPW 0.2	0.2µm
CPP/CPW 0.5	0.5µm
CPP/CPW 1.0	1.0µm
CPP/CPW 2.5	2.5µm
CPP/CPW 5.0	5.0µm
CPP/CPW 10	10.µm
CPP/CPW 15	15.µm
CPP/CPW 20	20µm
CPP/CPW 40	40µm
CPP/CPW 70	70µm

### PART NUMBERING SYSTEM

**CPP  
CPW**

**2.5 - 10**

**B**

**S**

#### MICRON RATING

0.2  
0.5  
1.0  
2.5  
5.0  
10.0  
15.0  
20.0  
40.0  
70.0

#### CARTRIDGE LENGTH

10"  
20"  
30"  
40"

#### END CAP CONFIGURATIONS

B - DOE flat open ends with caps  
N - SOE recessed cup, internal 213 O-ring  
D - SOE flat closed end, external 222 O-ring  
R - SOE recessed cup, external 222 O-ring  
F - SOE flat closed end, external 226 O-ring  
G - SOE fin end, external 226 O-ring  
C - SOE fin end, external 222 O-ring

#### GASKET / O-RING MATERIAL

S - Silicone (standard O-rings)  
B - Buna N (standard gaskets)  
V - Viton A  
E - EPDM  
T - Teflon  
TV - Teflon Encapsulated Viton

**PLEATED CARTRIDGES**

**High Purity – PP**

**Pleated Polypropylene Cartridge**

**Pleated Polypropylene Cartridges** are designed for use in most applications where absolute rated pleated filtration is needed. Designed to hold 6.5 square feet of filtration media, our High Purity – PP Cartridge is a great value. These cartridges are constructed with 100% polypropylene materials and assembled using the latest thermal bonding equipment. Efficiency Rating is 99.98% (Beta 5000).



**FLOW RATE** 10 inch (250 mm) Cartridges  
Water Flow Rate (LPM)

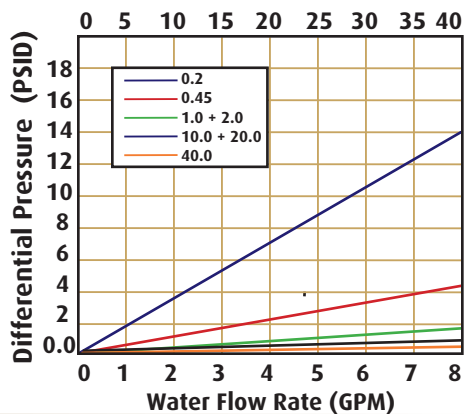

**TYPICAL APPLICATIONS**

- Food and Beverage
- Photographic
- Deionized Water
- R.O. Membrane
- Prefiltration
- Process Water
- Fine Chemicals
- Plating Chemicals
- Wastewater

**CONSTRUCTION MATERIALS**

**Filtration Media** ..... Polypropylene  
**Support Media** ..... Polypropylene  
**End Caps** ..... Polypropylene  
**Center Core** ..... Polypropylene  
**Outer Support Cage** ..... Polypropylene  
**O-rings/Gaskets** ..... Buna, Viton, EPDM, Silicone, Teflon® Encapsulated Viton

**ORDERING INFORMATION**

PP	(Pore Size)	A	(Length)	C	(End Cap Code)	O-Rings/Gaskets	Addrs
	0.2		10 (25.4 cm)		B = DOE W/gasket – and caps	B = Buna	I = SS Insert
	0.45		20 (50.8 cm)		C = 222 W/Spear	E = EPDM	HP = Heavy Poly Core
	1.0		30 (76.2 cm)		D = 222 W/Closed Flat Cap	S = Silicone	
	2.0		40 (101.6 cm)		E = 222 W/Spring	V = Viton	
	5.0				F = 226 W/Closed Flat Cap	T = Teflon	
	10.0				G = 226 W/Spear	Encapsulated Viton	
	20.0				H = 226 W/Spring		
	40.0				J = Polypropylene Extender		
					L = Spring		
					N = SOE Recessed Cap, internal 213 O-ring		

**SANITIZATION/STERILIZATION**

**Filtered Hot Water** ..... 90° C  
**Chemical Sanitization** - Industry standard concentrations of hydrogen peroxide, paracetic acid, sodium hypochlorite and other selected chemicals.

**DIMENSIONS**

**Length:**  
10 to 40 inches (25.4 to 101.6 cm) nominal  
**Outside Diameter:**  
2.70 inches (7.0 cm) nominal

**MAXIMUM RECOMMENDED OPERATING CONDITIONS**

**Change Out** ..... ΔP-35PSI  
**Temperature** ..... 180° F (82° C)

**PRODUCT PURITY**

All components FDA acceptable per 21 CFR.



# High Purity – FG

## Pleated Microfiberglass Cartridge

## PLEATED CARTRIDGES

**Pleated Microfiberglass Cartridges** offer an economical, absolute rated, filtration solution for both liquids and gases. They offer excellent flow rates and long service life with an exceptional ability to retain both deformable and non-deformable particles. High Purity — FG Cartridges are constructed with absolute rated borosilicate microfiberglass media that offers high dirt-loading capacities. The natural positive charge of the glass fiber also aids in the retention of negatively charged particulates such as bacteria, endotoxin, and a variety of colloidal materials.

### FLOW RATE

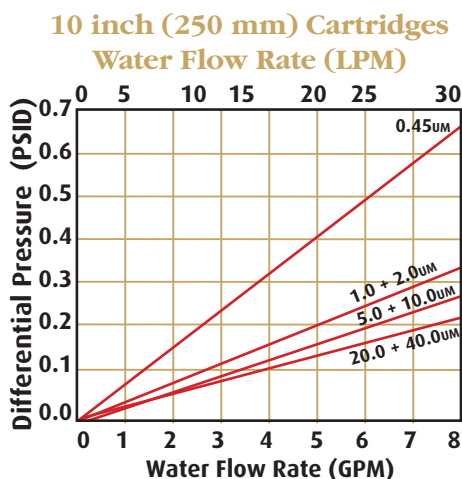

### TYPICAL APPLICATIONS

- Membrane Prefiltration
- Sterile Air
- Corn Syrup
- R.O. Prefiltration
- Wine Clarification
- Aromatic Hydrocarbons
- Oilfield Completion
- Fluids

### CONSTRUCTION MATERIALS

**Filtration Media** – FDA Borosilicate Microfiberglass with acrylic binder.

**Support Media** – Spun-bonded polyester laminated on both upstream and downstream sides.

**End Caps** ..... Polypropylene

**Center Core** ..... Fiberglass

**Outer Support Cage** ..... Polypropylene

**O-rings/Gaskets** ..... Buna, Viton, EPDM, Silicone, Teflon® Encapsulated Viton

**Note:** Contact factory for information on high-temperature stainless construction options.

### ORDERING INFORMATION

FG (Pore Size)	A	(Length)	C	(End Cap Code)	O-Rings/Gaskets	Adders
0.45		10 (25.4 cm)		B = DOE W/gasket – and caps	B = Buna	I = SS Insert
1.0		20 (50.8 cm)		C = 222 W/Spear	E = EPDM	
2.0		30 (76.2 cm)		D = 222 W/closed Flat Cap	S = Silicone	
5.0		40 (101.6 cm)		E = 222 W/Spring	V = Viton	
10.0				F = 226 W/closed Flat Cap	T = Teflon	
20.0				G = 226 W/Spear	Encapsulated	
40.0				H = 226 W/Spring	Viton	
				J = Polypropylene Extender		
				L = Spring		
				N = SOE Recessed Cap, internal 213 O-ring		



### ABSOLUTE FILTRATION RATINGS

99.98% (Bx=5000) removal efficiencies.

### SANITIZATION

**Filtered Hot Water** .....90 °C for 30 minutes at maximum of 15 PSID

### DIMENSIONS

**Length:**

10 to 40 inches (25.4 to 101.6 cm) nominal

**Outside Diameter:**

2.70 inches (7.0 cm) nominal

### MAXIMUM RECOMMENDED OPERATING CONDITIONS

**Change Out** ..... ΔP-35PSI

**Temperature** ..... 200 °F (93 °C)

**Optional Stainless Construction** ..... 275 °F (135 °C)

### PRODUCT PURITY

All components FDA acceptable per 21 CFR.



**PLEATED  
CARTRIDGES**

# High Purity – PES Membrane

## Hydrophilic Polyethersulfone (PES) Membrane for Liquid Filtration Applications

**PES Cartridges** are designed for general purpose use wherever a cost effective membrane filter is required. Manufactured to hold the maximum amount of filter media that can be completely and effectively utilized in a cartridge. PES Membrane Cartridges are manufactured from an inherently hydrophilic PES membrane. The cartridge offers excellent flow characteristics, extended service life, and broad chemical compatibility.



### FLOW RATE

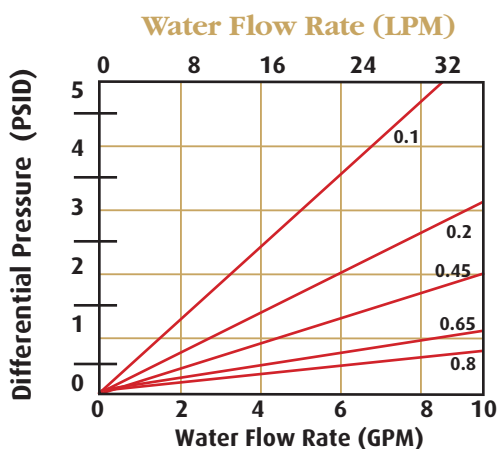

### TYPICAL APPLICATIONS

- Delonized Water Systems
- Recirculating Fluids
- General-Use Water Filtration
- Chemical Filtration
- Liquid Clarification

### CONSTRUCTION MATERIALS

**Membrane** ..... Polyethersulfone (PES)  
**Support Media** ..... Polypropylene  
**End Caps** ..... Polypropylene  
**Center Core** ..... Polypropylene  
**Outer Support Cage** ..... Polypropylene  
**O-rings/Gaskets** ..... Buna, Viton, EPDM, Silicone, Teflon® Encapsulated Viton

### ORDERING INFORMATION

MPES (Pore Size)	A (Length)	C (End Cap Code)	O-Rings/Gaskets	Options	Grade
0.04	10 (25.4 cm)	B = DOE W/gasket – and caps	B = Buna	I = 316SS Inset	G = General
0.1	20 (50.8 cm)	C = 222 W/Spear	E = EPDM	O = DI Flush	W = Water
0.2	30 (76.2 cm)	D = 222 W/Closed Flat Cap	S = Silicone		E = Electronics
0.45	40 (101.6 cm)	E = 222 W/Spring	V = Viton		F = Food & Beverage
0.65		F = 226 W/Closed Flat Cap	T = Teflon		
0.8		G = 226 W/Spear	Encapsulated Viton		
		H = 226 W/Spring			
		J = Polypropylene Extender			
		L = Spring			
		N = SOE Recessed Cap, internal 213 O-ring			

### SANITIZATION

**Filtered Hot Water** ..... 88° C for 30 minutes at a maximum of 15psid  
 Cartridges are chemically compatible with most ultra-pure chemicals, solvents, and sanitizing agents.

### DIMENSIONS

**Length:**  
 10 to 40 inches (25.4 to 101.6 cm) nominal  
**Outside Diameter:**  
 2.70 inches (7.0 cm) nominal

### MAXIMUM RECOMMENDED OPERATING CONDITIONS

**Maximum Temperature** ..... 176° F (80° C)

### MAXIMUM DIFFERENTIAL PRESSURES

**Forward** ..... 50 psi (3.4 bar) at 20° C  
**Reverse** ..... 45 psi (2.7 bar) at 20° C

### PRODUCT PURITY

All components FDA acceptable per 21 CFR.



# High Purity – Nylon 66 Membrane

Nylon Membrane for Liquid Applications

PLEATED  
CARTRIDGES

MNY pleated cartridges are highly retentive, naturally hydrophilic, Nylon membrane filters that are specially designed for critical filtration requirements of aqueous fluids. The Nylon 6,6 membrane in an all-polypropylene construction provides excellent wet-out characteristics and superior flow performance per surface area as compared to other membrane cartridges. No additives, resins, surfactants or binders are used in the manufacturing process, which dramatically reduces rinse up time, extractables and downtime. MNY cartridges are perfectly suited for critical applications where superior flow and particle removal efficiency between 0.1 and 1.2 micron is required. MNY+ charged membranes provides enhanced retention of smaller negatively charged particles such as endotoxins by electro-kinetic mechanisms.



## FLOW RATE

The following table represents typical water flow at one psi (69 mbar) pressure differential across a single 10 inch cartridge element. The test fluid is water at ambient temperature. Extrapolation for housing with multiple elements and higher pressure drops is acceptable, but as flows increase the pressure drop of the housing becomes more apparent.

PORE SIZE	GPM
0.1 M	1.0
0.2 M	1.5
0.45 M	4.0
0.65 M	6.0

## CONSTRUCTION MATERIALS

Filtration Media .....	Nylon
Support Media .....	Polypropylene
End Caps .....	Polypropylene
Center Core .....	Polypropylene
Outer Support Cage .....	Polypropylene
O-rings/Gaskets .....	Buna, Viton, EPDM, Silicone, Teflon® Encapsulated Viton

## ORDERING INFORMATION

MNY	(Pore Size)	A	(Length)	C	(End Cap Code)	O-Rings/Gaskets	Options	Grade
MNY+	0.03		10 (25.4 cm)		B = DOE W/gasket – and caps	B = Buna	I = 316SS Inset	G = General
	0.05		20 (50.8 cm)		C = 222 W/Spear	E = EPDM	O = DI Flush	E = Electronics
	0.1		30 (76.2 cm)		D = 222 W/Closed Flat Cap	S = Silicone		F = Food & Beverage
	0.2		40 (101.6 cm)		E = 222 W/Spring	V = Viton		
	0.45				F = 226 W/Closed Flat Cap	T = Teflon		
	0.65				G = 226 W/Spear	Encapsulated Viton		
	0.80				H = 226 W/Spring			
	1.20				J = Polypropylene Extender			
					L = Spring			
					N = SOE Recessed Cap,			

## SANITIZATION/STERILIZATION

Filtered Hot Water .....	90° C
Autoclave .....	127° C, 30 min, multiple cycles
In-line Stream .....	135° C, 30 min, multiple cycles
Chemical Sanitization – Industry standard concentrations of hydrogen peroxide, paracetic acid, sodium hypochlorite and other selected chemicals.	

## DIMENSIONS

Length:	10 to 40 inches (25.4 to 101.6 cm) nominal
Outside Diameter:	2.75 inches (7.0 cm) nominal

## MAXIMUM DIFFERENTIAL PRESSURES

Forward .....	50 psi (3.4 bar) at 20° C
Reverse .....	40 psi (2.7 bar) at 20° C

## PLEATED CARTRIDGES

# High Purity – General Grade Teflon

## Teflon Membrane for Liquid and Air Applications

**General Grade Teflon Cartridges** are designed for general purpose use wherever a cost effective Teflon membrane filter is required. Typical applications include filtration of aggressive fluids, vent filtration, air and gas filtration. These cartridges are found in the manufacturing processes of pharmaceutical companies, semi-conductor manufacturers and bulk chemical companies. Priced below special purpose cartridges, general grade cartridges are still manufactured with the same careful attention to quality and performance.

### FLOW RATE

The following table represents typical water flow at psi (69 mbar) pressure differential across a single 10 inch cartridge element. The test fluid is water at ambient temperature. Extrapolation for housings with multiple elements and higher pressure drops is acceptable, but as flows increase the pressure drop of the housing becomes more apparent.

PORE SIZE	GPM
0.1 M	1.25
0.2 M	2.8
0.45 M	5.7
1.0 M	9.0
3.0 M	11.4



### SANITIZATION/STERILIZATION

**Autoclave** ..... 127° C, 30 min, multiple cycles

**In-line Stream** ..... 135° C, 30 min, multiple cycles

**Chemical Sanitization** – Industry standard concentrations of hydrogen peroxide, paracetic acid, sodium hypochlorite and other selected chemicals.

### CONSTRUCTION MATERIALS

**Filtration Media** ..... Teflon®  
**Support Media** ..... Polypropylene  
**End Caps** ..... Polypropylene  
**Center Core** ..... Polypropylene  
**Outer Support Cage** ..... Polypropylene  
**O-rings/Gaskets** ..... Buna, Viton, EPDM, Silicone, Teflon® Encapsulated Viton

### DIMENSIONS

**Length:**

10 to 40 inches (25.4 to 101.6 cm) nominal

**Outside Diameter:**

2.75 inches (7.0 cm) nominal

### MAXIMUM DIFFERENTIAL PRESSURES

**Forward** ..... 50 psi (3.4 bar) at 20° C

**Reverse** ..... 45 psi (2.7 bar) at 20° C

### ORDERING INFORMATION

MPTFE (Pore Size)	A	(Length)	C	(End Cap Code)	O-Rings/Gaskets	Options
0.1		10 (25.4 cm)		B = DOE W/gasket – and caps	B = Buna	I = 316SS Inset
0.2		20 (50.8 cm)		C = 222 W/Spear	E = EPDM	
0.45		30 (76.2 cm)		D = 222 W/Closed Flat Cap	S = Silicone	
1.0		40 (101.6 cm)		E = 222 W/Spring	V = Viton	
3.0				F = 226 W/Closed Flat Cap	T = Teflon	
				G = 226 W/Spear	Encapsulated Viton	
				H = 226 W/Spring		
				J = Polypropylene Extender		
				L = Spring		
				N = SOE Recessed Cap, internal 213 O-ring		



# Pleated Cellulose

## PLEATED CARTRIDGES

**Series C cellulose cartridges** are designed for general water filtration purposes. They are economical, yet highly effective, at reducing sediment particulates down to nominal 20 micron in size, which is about one half the size of visible particles as seen with the naked eye.

Pleated construction of corrugated media with over 16 squared ft per 4 1/2" diameter by 9 3/4" long cartridges provides increased surface area and strength, which results in extended life. An external netted sheath provides extra support to protect against system pulsating. End caps are fused to the cellulose media preventing bypass and forming a gasket sealing area.



**Type:** Pleated Corrugated Cellulose

**Construction:** Resin Impregnated Cellulose Media  
Vinyl Plastisol End Caps  
Polypropylene Core

**Operating Temperature Range:** 40...F (4.4...C) to 145...F (63...C)

**Micron Rating:** Nominal 1, 5, 20

### DIMENSIONS

2 5/8" diam. x 9 3/4", 10" length  
2 5/8" diam. x 19 1/2", 20" length  
2 5/8" diam. x 30" length  
2 5/8" diam. x 40" length  
4 1/2" diam. x 9 3/4", 10" length  
4 1/2" diam. x 20" length

### MAXIMUM DIFFERENTIAL PRESSURES

10 GPM  
15 GPM  
20 GPM  
25 GPM  
25 GPM  
40 GPM

### SELECTION GUIDE

C	5	x	10	BB
Filter Media	Micron Rating		Length	Tube O.D.
C - Cellulose	1			Blank = 2 5/8"
	5		9 3/4"	All Filters are standard
	20		10"	2 5/8" O.D.
			19 1/2"	Unless otherwise specified
			20"	
			30"	
			40"	
				BB = 4 1/2"

## PLEATED CARTRIDGES

### Pleated Polyester

The chemical and bacteria resistance of the Series PE polyester media makes these cartridges suitable for most light industrial applications, swimming pool and spa, and well water applications. The durable, non-woven polyester fabric is reusable, while being pleated to maximize its dirt holding capacity and extending the time period between changes.

The 2 5/8" diameter by 9 3/4" length has more than 4 squared ft of fabric media while the larger 4 1/2" diameter by 9 3/4" long version has more than 16 squared ft.

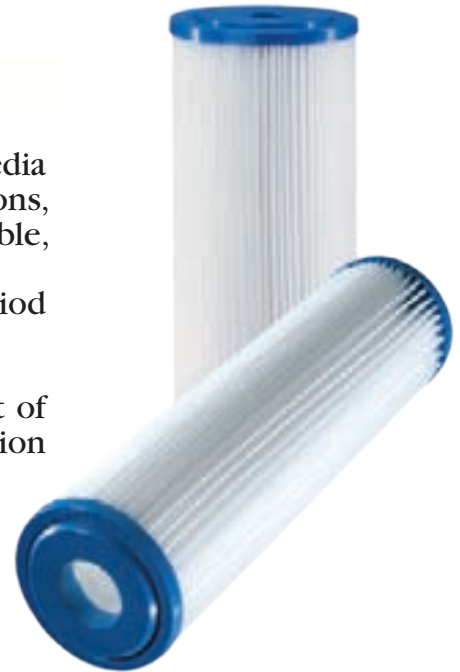

**Type:** Pleated Non-Woven Polyester

**Construction:** Non-Woven Polyester Fabric Media  
Vinyl Plastisol End Caps  
Polypropylene Core

**Operating Temperature Range:** 40...F (4.4...C) to 125...F (52...C)

**Micron Rating:** Nominal 1, 5, 10, 20, 50

#### DIMENSIONS

2 5/8" diam. x 9 3/4", 10" length

2 5/8" diam. x 19 1/2", 20" length

2 5/8" diam. x 30" length

2 5/8" diam. x 40" length

4 1/2" diam. x 9 3/4", 10" length

4 1/2" diam. x 20" length

#### MAXIMUM DIFFERENTIAL PRESSURES

10 GPM

15 GPM

20 GPM

25 GPM

25 GPM

40 GPM

#### SELECTION GUIDE

PE	5	x	10	BB
Filter Media	Micron Rating		Length	Tube O.D.
PE-Polyester	1		9 3/4"	Blank = 2 5/8" O.D.
	5		10"	
	10		19 1/2"	
	20		20"	
			30"	
	50		40"	
				BB - 4 1/2" O.D.



## Pleated Polypropylene

Series PP polypropylene cartridges are designed for residential, commercial, and industrial filtration applications. Constructed of durable, chemical resistant polypropylene media, they can be employed on many acids, alkalies, plating solutions, water remediation, and saline solutions.

4ft<sup>2</sup> of fabric media has been pleated for the standard 2 3/4" diameter by 9 3/4" long cartridge and over 16ft<sup>2</sup> for the larger 4 1/2" diameter by 9 3/4" long version.

Matrix's Separations newly and recently developed Series PP polypropylene cartridge filters employ a five (5) layered, high porosity "Bi-Component" polypropylene media consisting of both spun bonded and melt blown polypropylene layers laminated together by ultrasonic sealing in order to provide depth filtration to the media. This depth filtration will allow the cartridge to collect more dirt particulate and in most instances offer a longer life. The soft spun bonded polypropylene, having distinct dot patterns, is employed on the outer three (3) layers to serve as a prefilter to reduce larger particles while the smooth textured dernier melt blown polypropylene, which has been calandered in order to reduce the media pore size, is incorporated on the inner two (2) layers for microfiltration. This arrangement of both the "pre" and "post" filter components provides two separate gradient layers in one filter. "Gradient Density" filters reduce larger particles, which would blind-off ordinary surface filters on their outer layers, while reducing the final particles on their inner layers. This design is an advancement in filtration technology and maximizes utilization of the filtration media while enhancing overall cartridge performance. Cartridge ends have been immersed in vinyl plastisol, creating a unitized end cap and gasket which virtually eliminates bypass.

**Type:** Bi-Component Polypropylene

**Construction:** Pleated Bi-Component  
Polypropylene Vinyl Plastisol  
End Caps Polypropylene Core

**Operating Temperature Range:** 40...F (44...C) to 145...F (63...C)

**Micron Rating:** Nominal 1, 5, 10, 20, 50



### DIMENSIONS RECOMMENDED

### MAXIMUM FLOW RATES

2 3/4" diam. x 9 3/4", 10" length	10 GPM
2 3/4" diam. x 19 1/2", 20" length	15 GPM
2 3/4" diam. x 30" length	20 GPM
2 3/4" diam. x 40" length	25 GPM
4 1/2" diam. x 9 3/4", 10" length	25 GPM
4 1/2" diam. x 20" length	40 GPM

### SELECTION GUIDE

PP	5	x	10	BB
Filter Media	Micron Rating		Length	Tube O.D.
PP - Polypropylene	1		9 3/4"	
	5		10"	
	10		19 1/2"	Blank = 2 5/8" O.D.
	20		20"	
			30"	
	50		40"	
				BB = 4 1/2" O.D.

### BENEFITS OF "BI-COMPONENT" POLYPROPYLENE MEDIA

- LOWER clean initial pressure drops
- MORE uniform filtration & overall enhanced cartridge performance
- HIGH particulate reduction efficiencies up to 95%
- OPERATE at HIGHER velocities & flow rates
- GREATER degree of depth filtration
- ADDED loading capabilities
- "Gradient Density" filtration

Application Notes

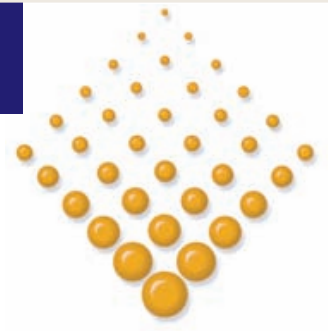

**MATRIX**  
SEPARATIONS



# Carbon Cartridge Filters

## CARBON CARTRIDGE FILTERS

Matrix's Activated Carbon Cartridge "C" Series is specifically designed for water, chemical and electroplating solutions, and represents today's best technology. The series, characterized by distinctive white, yellow or blue outer netting, is the ideal choice for either continuous or batch treatment of most applications.

### TYPICAL APPLICATIONS

- DI Prefilters
- Dye Stripping
- Electronics
- Metal Finishing
- Plating
- Potable Water
- Printed Circuits
- RO Systems
- Semi-Conductors
- Solvent Recovery
- Specialty Chemicals

This is to be used as a general reference only. The supplier assumes no responsibility or liability for the accuracy or completeness or results obtained by the use of this information. Users are advised to make their own test to determine the safety and suitability of each product or product combination.



### BENEFITS

#### C-155 SERIES

- Eliminate the past requirement for filter aides and filtration after carbon treating.
- Pre-washed to further guarantee no carbon bleed-off.
- Resistant without breakdown in both strongly acid and strongly alkaline solutions up to 180 F (82 C).
- Contains no cellulose or other products that could contribute to plating porosity or brittleness.
- Each nominal 10" length contains approximately 4 oz. of sulfur-free highly purified vegetable base carbon and may be used at up to 3 gpm flow for continuous treating. 1.5 gpm is acceptable for batch treating.
- Available in all standard lengths up to 30" and in two diameters. 2-3/4 and 2-5/8 O.D.
- Outer Polyolefin netting for surface integrity and appearance.

#### C-230 SERIES

- Contains approximately 70 grams of a finely pulverized blend of activated carbon to assure removal of the chlorine taste, as well as, organic chemical associated colors.
- The C-230 Series contains a final filter phase for polishing and has been pre-washed to further assure no carbon bleed-off.
- The unique construction of the carbon containing filter phase makes water filtration possible as it is being carbon treated. This minimizes the premature exhaustion of the carbon activity sites in "dirty" water.
- A true depth-type cartridge which assures superior dirt holding capacity in sediment laden waters.
- Available only in standard 4 7/8" and 9 3/4" lengths. Special configurations are also available.
- All components approved for food contact use.

Features and Benefits (continued on next page)

**MATRIX**  
SEPARATIONS





## CARBON CARTRIDGE FILTERS

### FEATURES AND BENEFITS (CONTINUED)

#### C-232 SERIES

- Contains approximately 90 grams of a finely pulverized blend of activated carbon yielding wide spectrum capability to assure long life in removing both the chlorine taste, as well as, organic associated colors.
- Pre-washed to guarantee no carbon bleed-off.
- Inner polypropylene core for compressive strength.
- Outer fine mesh polyolefin netting for surface integrity and appearance.
- All components approved for food contact use.
- Available only in standard 4 7/8" and 9 3/4" lengths. Special configurations are also available.
- All components approved for food contact use.

#### C-234 SERIES

- Contains a blend of approximately 100 grams of finely pulverized carbon designed for dechlorination and removal of taste, odor, color and a wide range of organic chemicals.
- Cellulose-free for added protection against bacterial degradation.
- Has proven universal utility for all but those applications requiring a high level of THM removal.
- A cost effective approach to replace GAC canister types in many applications.
- Available in any specified length up to 40" in 2 3/4" OD. Special configurations are also available.
- **Flow Rate to 3 GPM per each 10" Length**
- **Construction details for part #'s not featured are available upon request.**

#### C-240 SERIES

- Contains a blend of approximately 120 grams of finely pulverized carbon effective on both high and low molecular weight organic chemicals.
- Offers true depth – type filtration for fine sediment
- High level of organic chemical and free-chlorine removal.
- Out performs a typical granular activated carbon (GAC) cartridge.
- Does not bleed carbon after repeated uses.
- Available in all standard lengths up to 30" and 2 3/4" diameter.
- All components approved for food contact use.

#### C-252 SERIES

- Contains a blend of 290 grams of finely pulverized carbon which is highly effective in reducing chlorine, taste, odors and most organic chemicals.
- Designed for large scale applications such as Point of Entry (POE), water vending and commercial applications where a high level of carbon is essential.
- Cellulose-free for added protection against bacterial degradation.
- Does not bleed carbon after repeated uses.
- Resistant to media break-down over normal pH ranges up to 160 degrees F.
- Available in lengths of 9 3/4" and 20" and a 4 5/8" outside diameter.
- All components approved for food contact use.

### SELECTION GUIDE

C-155X	9.8	T
Series	Length in Inches	Cartridge Diameter
C-155X	9.8	T = 2 5/8" OD
C-230X	10	Without T = 2 3/4" OD
C-232X	19.5	
C-234X	20	
C-240X	30	
C-252X		



# Filter Bags

## FILTER BAGS

Matrix's filter bags are ideal for almost any process filtration application requiring the removal of solids. Matrix's filter bags are made under stringent standards to assure consistent performance. This product performs at high flow rates where liquid with viscosities up to 10,000 cps requires filtration. Matrix filter bags offer superior dirt holding capacity when compared to other high efficiency filter bags on the market. The entire line of standard filter bags are available in a broad range of sizes and materials.

### FEATURES AND BENEFITS

- Heavy-duty fabric handle makes removal quick and easy.
- Bags are available with glazed surface to effectively control migration of fibers into the filtered product.
- Each bag is incinerable, reducing filter disposal cost.
- Standard filter bags fit most major competitive vessel models.
- Bags feature a carbon steel snap ring for positive sealing.

### TYPICAL APPLICATIONS

- Paints
- Pre-filters for finer filters
- Solvents
- Adhesives
- Coatings
- Coolants
- Petroleum Oils
- Resins
- Water
- Inks
- Beverages
- Edible Oils



**Matrix filter bags offer superior dirt holding capacity when compared to other high efficiency filter bags on the market.**

### MEDIA COMPATIBILITY OF FILTER BAG MATERIALS

Fiber	Organic Solvents	Vegetable & Petro Oils	Organic Alkalies	Oxidizing Acids	Mineral Agents	Acids	Degrees F
Polyester	Excellent	Excellent	Good	Good	Good	Good	300
Polypropylene	Excellent	Excellent	Excellent	Excellent	Good	Good	225
Nylon	Excellent	Excellent	Good	Fair	Poor	Poor	325
Nomex	Excellent	Excellent	Good	Fair	Poor	Poor	475

This is to be used as a general reference only. The supplier assumes no responsibility or liability for the accuracy or completeness or results obtained by the use of this information. Users are advised to make their own test to determine the safety and suitability of each product or product combination.

**FILTER BAGS**

# Building A Filter Bag Part Number

**PE 50 P 2 S WE**

Optional

**FIBER AND MICRON RATING**

Polyester Felt = PE  
1,3,5,10,25,50,75,100,200

Polypropylene Felt = PO  
1,3,5,10,25,50,100,200

Oil Absorbing = Oil-X  
25

Nylon Monofilament Mesh = NMO  
1, 5, 10, 15, 25, 35, 45, 55,75,100,  
150, 200, 250, 300, 400, 600, 800, 1000

Polypropylene Monofilament Mesh = PMO  
150, 200, 250, 300, 400, 600, 800

Polyester Multifilament Mesh = PEM  
100,150, 200, 250, 300, 400,  
600, 800, 1500

Nylon Multifilament Mesh = NMU  
100, 150,200,250,300,400,  
600,800,1500

HT = Nomex 1, 5, 10, 25, 50, 100, 200

Lifting handles are standard on all filter bags.

**RING OPTIONS**

- SS..... Stainless Steel
- P..... Polypropylene Sewn in Ring
- PC..... Polypropylene Flanged Collar
- S..... Plated Steel Sewn in Ring
- N/H..... No Handle

**BAG SIZE**

- 1 = 7 1/16" X 16 1/2"
- 2 = 7 1/16" X 32"
- 3 = 4 1/8" X 8"
- 4 = 4 1/8" X 14"
- 5 = 4" X 24"
- 7 = 5 5/8" X 15"
- 8 = 5 5/8" X 21"
- 9 = 5 5/8" X 32"
- 10 = 12" X 18" Tie On
- 11 = 12" X 32" Tie On
- 12 = 8" X 32"
- 30 = 4 1/16" X 11"
- 65 = 4 1/16" X 22"

**BAG FINISH OR COVER**

- P..... Standard Finish
- G..... Fiber Free Glazed
- PC..... Polyester Cover
- POC..... Polypropylene Cover



# Bag Selection Guide

## FILTER BAGS

This information is important in sizing the housing if an element is going to be placed into the housing.

The following data is based on one square foot of filtration media that is present in your bag. Divide the differential pressure by the number of square feet of media that is found in the selected bag to get your final rating.

The following chart is based on one centipoise, "water". If your liquid is above one please use the correction factor to determine your estimated pressure drop.

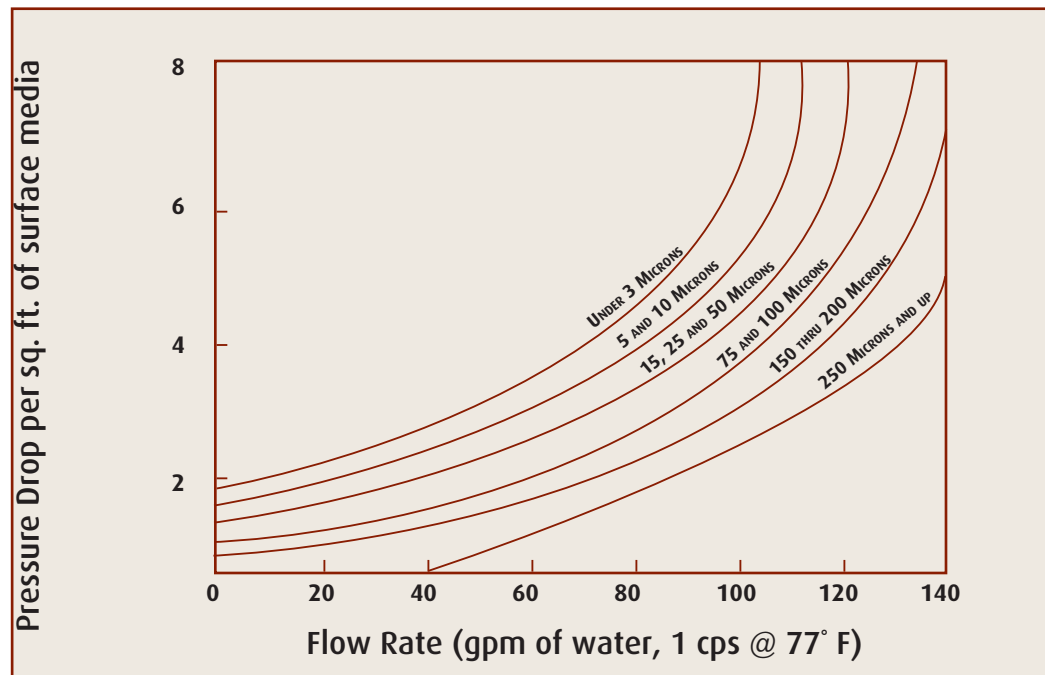

### Viscosity In Cps.

50  
100  
200  
400  
800  
1000  
2000  
4000  
6000  
8000

### Correction Factor

4.5  
8.3  
16.6  
27.7  
50.0  
56.2  
113.6  
161.0  
250.0  
325.0

**FILTER BAGS****Micron Reference Charts****WIRE MESH TO MICRON SIZE**

1 micron (1x10<sup>-6</sup> meters = 4x10<sup>-5</sup> inches  
(0.00004 inches))

<b><u>U.S. MESH</u></b>	<b><u>MICRONS</u></b>
10	2000
20	841
25	707
30	595
35	500
40	420
45	354
50	297
60	250
70	210
80	177
100	149
120	125
140	105
150	95
170	88
200	74
250	61
270	53
325	44
400	37
500	25
200x600	20
165x800	10
200x1400	5
325x2300	2

**RELATIVE MICRON COMPARISONS**

Beach Sand	>150
Granular Salt	100
Pin Point	80
Human Hair (DIA)	45-70
White Blood Cell	25
Plant Spores	15
Red Blood Cell	8
Fog Mist	5
Tobacco Smoke	.1-1
Carbon Black	.02-.1
Virus	.008-.1
Aqueous Salt	<.002

**TYPES OF SEPARATION**

Microns	
>1	Particle Filtration
08-1	Micro Filtration
007-.1	Ultra Filtration
.001-.009	Nano Filtration
<.002	Reverse Osmosis



# Cartridge Filter Housings

These cartridge housings offer a wide range of flow capacities and contaminant holding capabilities. The housings can accommodate from 1 to 205 cartridges around. All housings can be supplied with an ASME code stamp, if required.

## STANDARD BENEFITS AND OPTIONS

### BENEFITS

- Low pressure drop
- Permanently piped housings are opened without special tools and without disturbing the piping
- A Machined cover gasket groove will provide positive O-ring sealing
- Easy to clean
- In-line inlet and outlet
- Stainless steel internals

### OPTIONS

- 2 outlet styles
- Carbon steel, 304 or 316 stainless steel housings
- ASME code stamp
- O-ring seals:  
Buna N, EPR, Viton®, Teflon®
- Accommodates 10, 20, 30 or 40-inch cartridges
- Flanged connections for 3/4 through 12-inch pipe
- V posts or threaded center posts
- Units accept DOE or 222 style cartridges

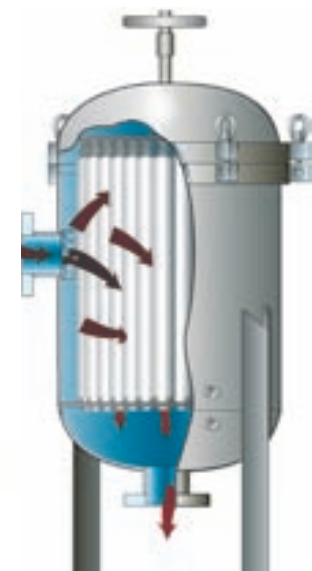

## HOW THEY WORK

Unfiltered fluid enters the housing and is distributed evenly around the cartridges, from outside to inside. Solids are collected on the outside for easy removal. The filtered fluid then exits through the outlet pipe.

Center: Models 4, 6 and 8  
Bottom Right: Models 12 thru 48

## CARTRIDGE FILTER HOUSINGS

### Cartridge Requirements

The following table gives the number of cartridges needed for each housing model.

Model Number and Diameter	Cartridge Lengths	Number of Cartridges	Equivalent 10-inch lengths	Available Pipe Sizes
Model 4	10-inch	1	1	3/4, 1, 1-1/4, 1-1/2, 2
	20-inch	1	2	
	30-inch	1	3	
	40-inch	1	4	
Model 6	20-inch	3	6	3/4, 1, 1-1/4, 1-1/2, 2, 3
	30-inch	3	9	
	40-inch	3	12	
Model 8	20-inch	6	12	3/4, 1, 1-1/4, 1-1/2, 2, 3
	30-inch	6	18	
	40-inch	6	24	
Model 12	20-inch	12	24	2,3,4
	30-inch	12	36	
	40-inch	12	48	
Model 16	20-inch	20	40	2,3,4
	30-inch	20	60	
	40-inch	20	80	
Model 18	20-inch	27	54	2,3,4
	30-inch	27	81	
	40-inch	27	108	
Model 22	20-inch	40	80	3,4,6
	30-inch	40	120	
	40-inch	40	160	
Model 24	20-inch	52	104	3,4,6
	30-inch	52	156	
	40-inch	52	208	
Model 30	20-inch	82	164	4,6,8
	30-inch	82	246	
	40-inch	82	328	
Model 36	20-inch	116	232	6,8,10
	30-inch	116	348	
	40-inch	116	464	
Model 42	20-inch	158	316	8,10,12
	30-inch	158	474	
	40-inch	158	632	
Model 48	20-inch	205	410	8,10,12
	30-inch	205	615	
	40-inch	205	820	

### Determining Housing Pressure Drop Only

The pressure drops shown on the graph are reliable for all cartridge housings. The pressure drop of any housing is governed by the size of the inlet and outlet, not the vessel itself.

- Using desired pipe size and approximate flow rate, determine the basic pressure drop from the graph.
- Multiply the pressure drop obtained in step 1 by the viscosity correction factor found in the accompanying table.
- You now have the pressure drop for an empty cartridge housing.
- The user selected cartridge pressure drop must then be added to the housing pressure.

### VISCOSITY FACTORS

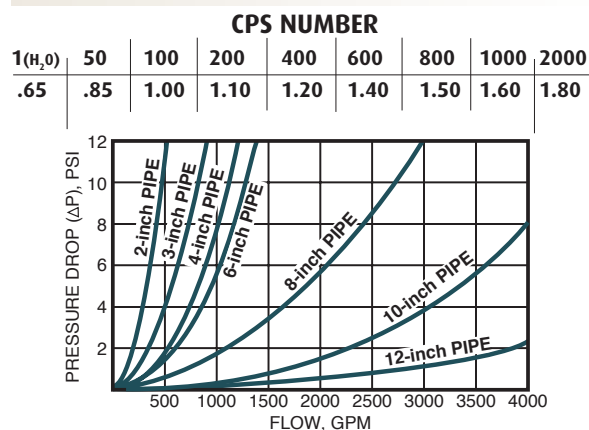

\*Based on housing only. Fluid viscosity, filter cartridge used, and expected dirt loading should be considered when sizing a filter.



# Dimensions for Models 4, 6 and 8 (IN)

## CARTRIDGE FILTER HOUSINGS

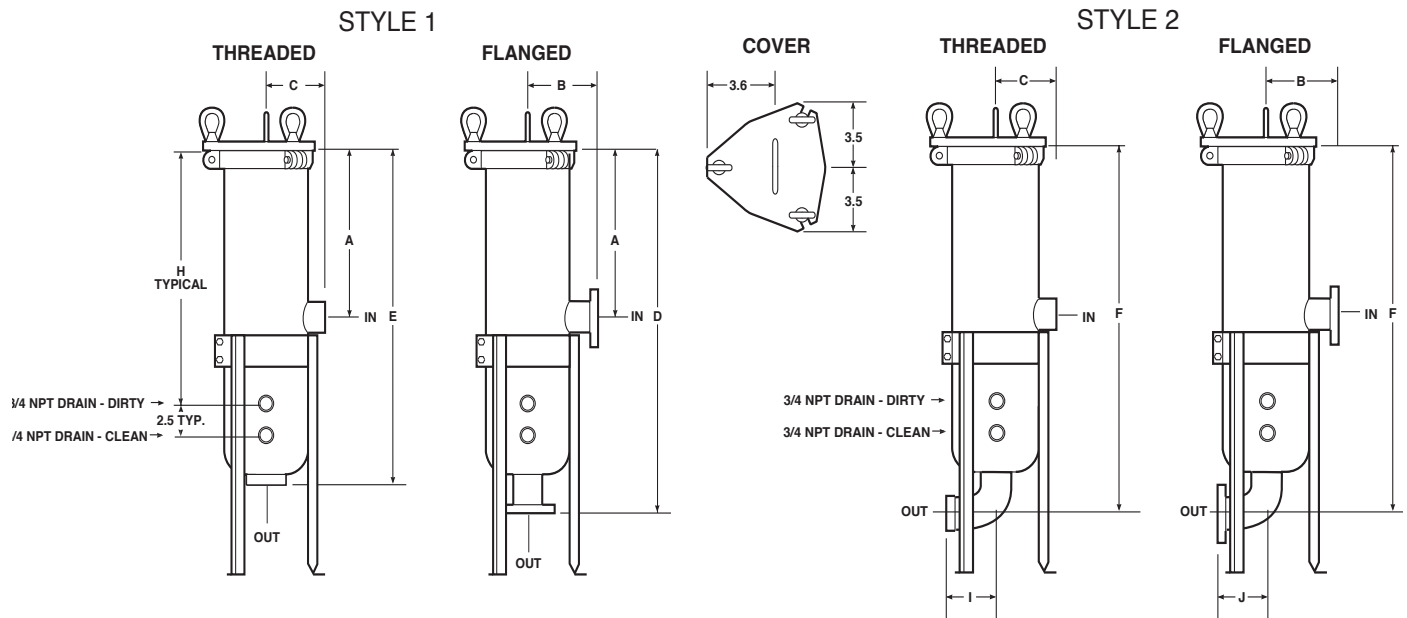

Model No.	Pipe Size	A	B	C	D	E	F	H	I	J
4110	3/4	6.0	5.0	3.5	20.0	18.6	18.9	11.8	1.9	4.0
	1	6.0	5.0	3.5	20.0	18.8	19.3	11.8	2.5	4.0
	1-1/4	6.0	5.0	3.5	20.0	18.8	19.7	11.8	2.9	4.0
	1-1/2	6.0	5.0	3.5	20.0	18.8	20.1	11.8	3.3	4.0
2	6.0	5.0	3.5	20.0	18.7	20.8	11.8	4.0	5.0	
4120	3/4	11.0	5.0	3.5	30.0	28.6	28.9	21.8	1.9	4.0
	1	11.0	5.0	3.5	30.0	28.8	29.3	21.8	2.5	4.0
	1-1/4	11.0	5.0	3.5	30.0	28.8	29.7	21.8	2.9	4.0
	1-1/2	11.0	5.0	3.5	30.0	28.8	30.1	21.8	3.3	4.0
2	11.0	5.0	3.5	30.0	28.7	30.8	21.8	4.0	5.0	
4130	3/4	16.0	5.0	3.5	40.0	38.6	38.9	31.8	1.9	4.0
	1	16.0	5.0	3.5	40.0	38.8	39.3	31.8	2.5	4.0
	1-1/4	16.0	5.0	3.5	40.0	38.8	39.7	31.8	2.9	4.0
	1-1/2	16.0	5.0	3.5	40.0	38.8	40.1	31.8	3.3	4.0
2	16.0	5.0	3.5	40.0	38.7	40.8	31.8	4.0	5.0	
4140	3/4	21.0	5.0	3.5	50.0	48.6	48.9	41.8	1.9	4.0
	1	21.0	5.0	3.5	50.0	48.8	49.3	41.8	2.5	4.0
	1-1/4	21.0	5.0	3.5	50.0	48.8	49.7	41.8	2.9	4.0
	1-1/2	21.0	5.0	3.5	50.0	48.8	50.1	41.8	3.3	4.0
2	21.0	5.0	3.5	50.0	48.7	50.8	41.8	4.0	5.0	

Dimensions are reference only and should not be used for hard plumbing. Consult factory for certified drawings.



## CARTRIDGE FILTER HOUSINGS

### Dimensions for Models 4, 6 and 8 (IN) cont.

Model No.	Pipe Size	A	B	C	D	E	F	H	I	J
<b>6310</b>	3/4	6.0	6.0	4.0	21.0	18.7	18.9	11.8	1.9	5.0
	1	6.0	6.0	4.3	21.0	18.8	19.3	11.8	2.5	5.0
	1-1/4	6.0	6.0	4.3	21.0	18.8	19.7	11.8	2.9	5.0
	1-1/2	6.0	6.0	4.3	21.0	18.8	20.1	11.8	3.3	5.0
	2	6.0	6.0	4.3	21.88	18.8	20.8	11.8	4.0	5.0
	3	6.0	6.0	4.3	21.88	19.1	22.1	11.8	6.1	7.3
<b>6320</b>	3/4	11.0	6.0	4.0	31.0	28.7	28.9	21.8	1.9	5.0
	1	11.0	6.0	4.3	31.0	28.8	29.3	21.8	2.5	5.0
	1-1/4	11.0	6.0	4.3	31.0	28.8	29.7	21.8	2.9	5.0
	1-1/2	11.0	6.0	4.3	31.0	28.8	30.1	21.8	3.3	5.0
	2	11.0	6.0	4.3	31.88	28.7	30.8	21.8	4.0	5.0
	3	11.0	6.0	4.3	31.88	29.1	32.1	21.8	6.1	7.3
<b>6330</b>	3/4	16.0	6.0	4.0	41.0	38.7	38.9	31.8	1.9	5.0
	1	16.0	6.0	4.3	41.0	38.8	39.3	31.8	2.5	5.0
	1-1/4	16.0	6.0	4.3	41.0	38.8	39.7	31.8	2.9	5.0
	1-1/2	16.0	6.0	4.3	41.0	38.8	40.1	31.8	3.3	5.0
	2	16.0	6.0	4.3	41.88	38.8	40.8	31.8	4.0	5.0
	3	16.0	6.0	4.3	41.88	39.1	42.1	31.8	6.1	7.3
<b>6340</b>	3/4	21.0	6.0	4.0	51.0	48.7	48.9	41.8	1.9	5.0
	1	21.0	6.0	4.3	51.0	48.8	49.3	41.8	2.5	5.0
	1-1/4	21.0	6.0	4.3	51.0	48.8	49.7	41.8	2.9	5.0
	1-1/2	21.0	6.0	4.3	51.0	48.8	50.1	41.8	3.3	5.0
	2	21.0	6.0	4.3	51.88	48.8	50.8	41.8	4.0	5.0
	3	21.0	6.0	4.3	51.88	49.1	52.1	41.8	6.1	7.3
<b>8620</b>	3/4	11.0	7.5	5.3	32.1	29.7	30.1	21.8	1.9	5.0
	1	11.0	7.5	5.3	32.1	29.8	30.4	21.8	2.5	5.0
	1-1/4	11.0	7.5	5.3	32.1	29.8	30.7	21.8	2.9	5.0
	1-1/2	11.0	7.5	5.6	32.1	29.8	30.1	21.8	3.3	5.0
	2	11.0	7.5	5.8	32.1	29.8	31.8	21.8	4.0	5.0
	3	11.0	7.5	6.8	32.4	30.3	33.2	21.8	6.1	7.3
<b>8630</b>	3/4	16.0	7.5	5.3	42.1	39.7	40.1	31.8	1.9	5.0
	1	16.0	7.5	5.3	42.1	39.8	40.4	31.8	2.5	5.0
	1-1/4	16.0	7.5	5.3	42.1	39.8	40.7	31.8	2.9	5.0
	1-1/2	16.0	7.5	5.6	42.1	39.8	40.1	31.8	3.3	5.0
	2	16.0	7.5	5.8	42.1	39.8	41.8	31.8	4.0	5.0
	3	16.0	7.5	6.8	42.4	40.3	43.2	31.8	6.1	7.3
<b>8640</b>	3/4	21.0	7.5	5.3	52.1	49.7	50.1	41.8	1.9	5.0
	1	21.0	7.5	5.3	52.1	49.8	50.4	41.8	2.5	5.0
	1-1/4	21.0	7.5	5.3	52.1	49.8	50.7	41.8	2.9	5.0
	1-1/2	21.0	7.5	5.6	52.1	49.8	50.1	41.8	3.3	5.0
	2	21.0	7.5	5.8	52.1	49.8	51.8	41.8	4.0	5.0
	3	21.0	7.5	6.8	52.4	50.3	53.2	41.8	6.1	7.3

# Dimensions for Models 12-24 (IN)

## CARTRIDGE FILTER HOUSINGS

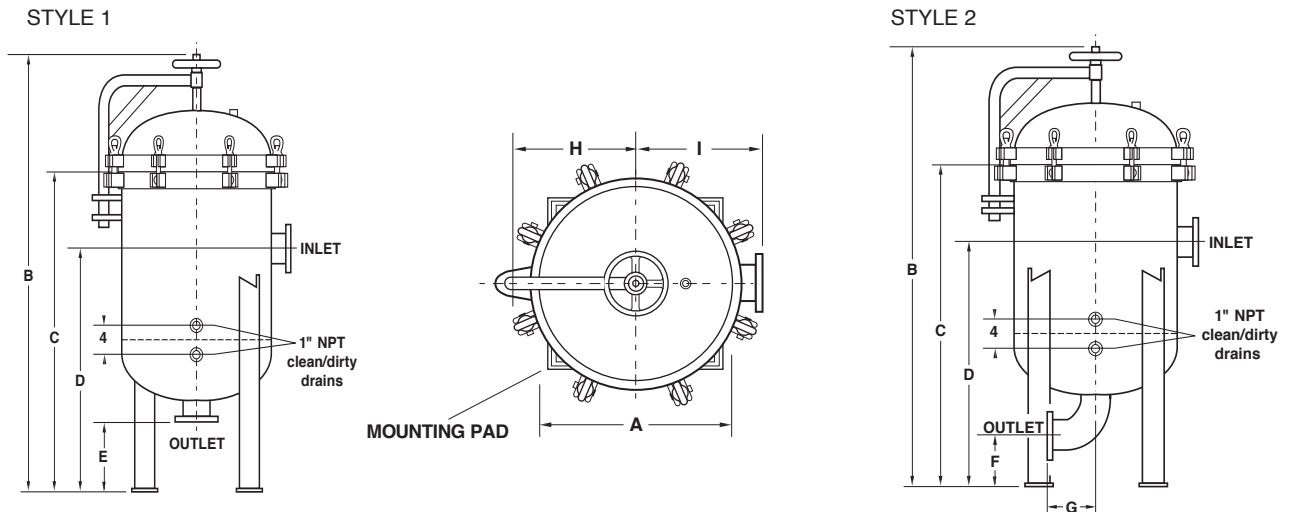

Model No.	No. of Cart.	Cart. Length	Pipe Size	STYLE 1					STYLE 2						Empty Weight (lbs)	Total Volume (cu. ft.)	
				A	B	C	D	E	B	C	D	F	G	H			I
12	12	20	2	12.0	59.1	43.1	33.1	12.0	50.6	34.6	24.6	4.5	5.5	9.3	10.0	370	2.2
			3						52.9	36.9	26.9	5.3	7.3	410			
			4						55.1	39.1	29.1	6.0	9.0				
	30	2	2	12.0	69.1	53.1	38.1	12.0	60.6	44.6	29.6	4.5	5.5	9.3	10.0	395	2.9
			3						62.9	46.9	31.9	5.3	7.3	410			
			4						65.1	49.1	34.1	6.0	9.0		425		
	40	2	2	12.0	79.1	63.1	43.1	12.0	70.6	54.6	34.6	4.5	5.5	9.3		10.0	420
			3						72.9	56.9	36.9	5.3	7.3	435			
			4						75.1	59.1	39.1	6.0	9.0		455		
16	20	20	2	16.0	61.1	44.1	34.1	12.0	52.6	35.6	25.6	4.5	5.5	10.9		12.0	450
			3						54.9	37.9	27.9	5.3	7.3	465			
			4						57.1	40.1	30.1	6.0	9.0		480		
	30	2	2	16.0	71.1	54.1	39.1	12.0	62.6	45.6	30.6	4.5	5.5	10.9		12.0	475
			3						64.9	47.9	32.9	5.3	7.3	495			
			4						67.1	50.1	35.1	6.0	9.0		510		
	40	2	2	16.0	81.1	64.1	44.1	12.0	72.6	55.6	35.6	4.5	5.5	10.9		12.0	505
			3						74.9	57.9	37.9	5.3	7.3	520			
			4						77.1	60.1	40.1	6.0	9.0		540		

Dimensions are reference only and should not be used for hard plumbing. Consult factory for certified drawings.

## CARTRIDGE FILTER HOUSINGS

### Dimensions for Models 12-24 (IN) cont.

Model No.	No. of Cart.	Cart. Length	Pipe Size	STYLE 1					STYLE 2					Empty Weight (lbs)	Total Volume (cu. ft.)				
				A	B	C	D	E	B	C	D	F	G			H	I		
18	27	20	2	18.0	62.1	44.6	34.6	12.0	53.6	36.1	26.1	4.5	5.5	11.9	13.0	480	4.7		
			3						55.9	38.4	28.4	5.3	7.3			500			
			4						58.1	40.6	30.6	6.0	9.0			515			
	30	2	2	18.0	72.1	54.6	39.6	12.0	63.6	46.1	31.1	4.5	5.5	11.9	13.0	515		6.1	
			3						65.9	48.4	33.4	5.3	7.3			530			
			4						68.1	50.6	35.6	6.0	9.0			550			
	40	2	2	18.0	82.1	64.6	44.6	12.0	73.6	56.1	36.1	4.5	5.5	11.9	13.0	550		7.6	
			3						75.9	58.4	38.4	5.3	7.3			565			
			4						78.1	60.6	40.6	6.0	9.0			580			
	22	40	20	2	22.0	64.1	45.6	35.6	12.0	55.6	37.1	27.1	4.5	5.5	13.9	15.0		615	7.3
				3						57.9	39.4	29.4	5.3	7.3				630	
				4						60.1	41.6	31.6	6.0	9.0				645	
30		2	2	22.0	74.1	55.6	40.6	12.0	65.6	47.1	32.1	4.5	5.5	13.9	15.0	655	9.5		
			3						67.9	49.4	34.4	5.3	7.3			670			
			4						70.1	51.6	36.6	6.0	9.0			690			
40		2	2	22.0	84.1	65.6	45.6	12.0	75.6	57.1	37.1	4.5	5.5	13.9	15.0	695	11.7		
			3						77.9	59.4	39.4	5.3	7.3			710			
			4						80.1	61.6	41.6	6.0	9.0			730			
24		52	20	2	24.0	65.1	46.1	36.1	12.0	56.6	37.6	27.6	4.5	5.5	14.9	16.0	665	8.8	
				3						58.9	39.9	29.9	5.3	7.3			680		
				4						61.1	42.1	32.1	6.0	9.0			700		
	30	2	2	24.0	75.1	56.1	41.1	12.0	66.6	47.6	32.6	4.5	5.5	14.9	16.0	710	11.4		
			3						68.9	49.9	34.9	5.3	7.3			725			
			4						71.1	52.1	37.1	6.0	9.0			740			
	40	2	2	24.0	85.1	66.1	46.1	12.0	76.6	57.6	37.6	4.5	5.5	14.9	16.0	750	14.0		
			3						78.9	59.9	39.9	5.3	7.3			770			
			4						81.1	62.1	42.1	6.0	9.0			785			
				6												830			



# Dimensions for Models 30-48 (IN)

## CARTRIDGE FILTER HOUSINGS

Model No.	No. of Cart.	Cart. Length	Pipe Size	STYLE 1					STYLE 2							Empty Weight (lbs)	Total Volume (cu. ft.)		
				A	B	C	D	E	B	C	D	F	G	H	I				
30	82	20	2	30.0	68.1	47.6	37.6	12.0	59.6	39.1	29.1	4.5	5.5	17.9	19.0	955	14.5		
			3						61.9	41.4	31.4	5.3	7.3	970					
			4						64.1	43.6	33.6	6.0	9.0	990					
			6						68.1	47.6	37.6	7.0	12.5	1035					
			8						72.4	51.9	41.9	8.3	16.0	1100					
		30	2	30.0	78.1	57.6	42.6	12.0	69.6	49.1	34.1	4.5	5.5	17.9	19.0	1030	18.6		
			3						71.9	51.4	36.4	5.3	7.3	1045					
			4						74.1	53.6	38.6	6.0	9.0	1060					
			6						78.1	57.6	42.6	7.0	12.5	1110					
			8						82.4	61.9	46.9	8.3	16.0	1170					
		40	2	30.0	88.1	67.6	47.6	12.0	79.6	59.1	39.1	4.5	5.5	17.9	19.0	1100	22.7		
			3						81.9	61.4	41.4	5.3	7.3	1120					
			4						84.1	63.6	43.6	6.0	9.0	1135					
			6						88.1	67.6	47.6	7.0	12.5	1180					
			8						92.4	71.9	51.9	8.3	16.0	1245					
36	116	20	2	36.0	71.1	49.1	39.1	12.0	62.6	40.6	30.6	4.5	5.5	20.9	22.0	1315	22.0		
			3						64.9	42.9	32.9	5.3	7.3	1330					
			4						67.1	45.1	35.1	6.0	9.0	1350					
			6						71.1	49.1	39.1	7.0	12.5	1395					
			8						75.4	53.4	43.4	8.3	16.0	1460					
		10	79.6	57.6	47.6	9.5	19.0	1570											
				30	2	36.0	81.1	59.1	44.1	12.0	72.6	50.6	35.6	4.5	5.5	20.9	22.0	1425	27.9
					3						74.9	52.9	37.9	5.3	7.3	1440			
					4						77.1	55.1	40.1	6.0	9.0	1460			
					6						81.1	59.1	44.1	7.0	12.5	1505			
8	85.4				63.4						48.4	8.3	16.0	1570					
10	89.6	67.6	52.6	9.5	19.0	1680													
		40	2	36.0	91.1	69.1	49.1	12.0	82.6	60.6	40.6	4.5	5.5	20.9	22.0	1535	33.8		
			3						84.9	62.9	42.9	5.3	7.3	1550					
			4						87.1	65.1	45.1	6.0	9.0	1570					
			6						91.1	69.1	49.1	7.0	12.5	1615					
			8						95.4	73.4	53.4	8.3	16.0	1680					
10	99.6	77.6	57.6	9.5	19.0	1790													
42	158	20	2	42.0	74.1	50.6	40.6	12.0	65.6	42.1	32.1	4.5	5.5	23.9	25.0	2030	31.6		
			3						67.9	44.4	34.4	5.3	7.3	2045					
			4						70.1	46.6	36.6	6.0	9.0	2060					
			6						74.1	50.6	40.6	7.0	12.5	2110					

## CARTRIDGE FILTER HOUSINGS

### Dimensions for Models 30-48 (IN) Cont.

Model No.	No. of Cart.	Cart. Length	Pipe Size	STYLE 1					STYLE 2							Empty Weight (lbs)	Total Volume (cu. ft.)	
				A	B	C	D	E	B	C	D	F	G	H	I			
			8							78.4	54.9	44.9	8.3	16.0			2170	
			10							82.6	59.1	49.1	9.5	19.0			2280	
			12							87.1	63.6	53.6	11.0	22.5			2415	
	30	2		42.0	84.1	60.6	45.6	12.0		75.6	52.1	37.1	4.5	5.5	23.9	25.0	2160	39.6
		3								77.9	54.4	39.4	5.3	7.3			2175	
		4								80.1	56.6	41.6	6.0	9.0			2195	
		6								84.1	60.6	45.6	7.0	12.5			2240	
		8								88.4	64.9	49.9	8.3	16.0			2305	
		10								92.6	69.1	54.1	9.5	19.0			2415	
		12								97.1	73.6	58.6	11.0	22.5			2550	
	40	2		42.0	94.1	70.6	50.6	12.0		85.6	62.1	42.1	4.5	5.5	23.9	25.0	2285	47.6
		3								87.9	64.4	44.4	5.3	7.3			2300	
		4								90.1	66.6	46.6	6.0	9.0			2320	
		6								94.1	70.6	50.6	7.0	12.5			2360	
		8								98.4	74.9	54.9	8.3	16.0			2430	
		10								102.6	79.1	59.1	9.5	19.0			2535	
		12								107.1	83.6	63.6	11.0	22.5			2670	
48	205	20	2	48.0	77.1	52.1	42.1	12.0		68.6	44.1	34.1	4.5	5.5	26.9	28.0	2510	43.2
			3							70.9	46.4	36.4	5.3	7.3			2520	
			4							73.1	48.6	38.6	6.0	9.0			2540	
			6							77.1	52.6	42.6	7.0	12.5			2585	
			8							81.4	56.9	46.9	8.3	16.0			2650	
			10							85.6	61.1	51.1	9.5	19.0			2760	
			12							90.1	65.6	55.6	11.0	22.5			2895	
	30	2		48.0	87.1	62.1	47.1	12.0		78.6	54.1	39.1	4.5	5.5	26.9	28.0	2655	53.7
		3								80.9	56.4	41.4	5.3	7.3			2670	
		4								83.1	58.6	43.6	6.0	9.0			2685	
		6								87.1	62.6	47.6	7.0	12.5			2730	
		8								91.4	66.9	51.9	8.3	16.0			2800	
		10								95.6	71.1	56.1	9.5	19.0			2905	
		12								100.1	75.6	60.6	11.0	22.5			3040	
	40	2		48.0	97.1	72.1	52.1	12.0		88.6	64.1	44.1	4.5	5.5	26.9	28.0	2800	64.1
		3								90.9	66.4	46.4	5.3	7.3			2815	
		4								93.1	68.6	48.6	6.0	9.0			2830	
		6								97.1	72.6	52.6	7.0	12.5			2880	
		8								101.4	76.9	56.9	8.3	16.0			2945	
		10								105.6	81.1	61.1	9.5	19.0			3050	
		12								110.1	85.6	65.6	11.0	22.5			3180	

# CARTRIDGE FILTER HOUSINGS

## How To Order

Build an ordering code as shown in the example.  
Each available only on the model sizes highlighted in the colored blocks preceding its description

**Key To Blocks:**

4	6	8	12
4	6	8	12
4	6	8	12
4	6	8	12

= Model 4  
= Model 6  
= Model 8  
= Model 12 etc.

**EXAMPLE:** 245230 4F 1 15 S B DOE VP C

**MODEL NO.**

4	6	8	12	16	18	22	24	30	36	42	48
---	---	---	----	----	----	----	----	----	----	----	----

**NUMBER OF CARTRIDGES<sup>4</sup>**  
(Around) Cartridges

4	6	8	12	16	18	22	24	30	36	42	48
---	---	---	----	----	----	----	----	----	----	----	----

**CARTRIDGE LENGTH<sup>4</sup>**

4	6	8	12	16	18	22	24	30	36	42	48
---	---	---	----	----	----	----	----	----	----	----	----

**PIPE SIZE NPT (female)**

4	6	8	12	16	18	22	24	30	36	42	48
---	---	---	----	----	----	----	----	----	----	----	----

**FLANGED<sup>1</sup>**

4	6	8	12	16	18	22	24	30	36	42	48
---	---	---	----	----	----	----	----	----	----	----	----

**HOUSING**

**OPTION**

**ASME CODE STAMP**  
C = Code

**CARTRIDGE SEALING**  
VP = V Post and Spring Seal  
TP = Threaded Post  
For other styles, consult factory

**CARTRIDGE DESIGN<sup>4</sup>**

4	6	8	12	16	18	22	24	30	36	42	48
---	---	---	----	----	----	----	----	----	----	----	----

DOE = Double-Open End  
SOE = Single-Open End  
222 = Double O-Ring  
226 = Bayonet Lock (Pall)

**COVER SEAL**

4	6	8	12	16	18	22	24	30	36	42	48
---	---	---	----	----	----	----	----	----	----	----	----

B = Buna N  
E = Ethylene Propylene  
V = Viton®  
TV = Teflon® Encapsulated Viton®  
TW = Teflon® (solid white)

**HOUSING MATERIAL<sup>2</sup>**

4	6	8	12	16	18	22	24	30	36	42	48
---	---	---	----	----	----	----	----	----	----	----	----

C = Carbon Steel  
S = 304 Stainless Steel  
S6 = 316 Stainless Steel

**PRESSURE RATING<sup>3</sup>**

4	6	8	12	16	18	22	24	30	36	42	48
---	---	---	----	----	----	----	----	----	----	----	----

15 = 150 psi (NPT or flanged)  
30 = 300 psi (NPT or flanged)

**PIPING STYLE<sup>2</sup>**

4	6	8	12	16	18	22	24	30	36	42	48
---	---	---	----	----	----	----	----	----	----	----	----

1 = Side Inlet, Bottom Outlet  
2 = In-line, Inlet-high, Outlet-low

- Flanges provided with the housing match the pressure rating of the vessel. Housings rated 150 psi have 150 class flanges. Housings rated 300 psi have 300 class flanges. Other styles and classes are available. ANSI B16.5 Pressure-Temperature rating tables determine flange class for ASME code housings. Consult factory.
- Consult factory for special options.
- Higher pressure ratings available. Consult factory.

**Pressure Drop Data**  
Cartridge filters are usually selected so that the clean pressure drop does not exceed 2 psi. Higher pressure drops may be tolerated when contaminant loading is low. The user must determine the appropriate cartridge for the application, and note the flow rate ΔP per cartridge as suggested by the media manufacturer.

### VISCOSITY FACTORS

	CPS NUMBER							
1 (H <sub>2</sub> O)	50	100	200	400	600	800	1000	2000
.65	.85	1.00	1.10	1.20	1.40	1.50	1.60	1.80

## CARTRIDGE FILTER HOUSINGS

### Cartridge Filters

Rugged, low-cost cartridge design for flow rates to 100 gpm\*

These cartridge-filter housings are rugged and low in cost. They hold five cartridges, in 10-inch, 20-inch, 30-inch, or 40-inch lengths, using industry standard designs (222, SOE, or DOE). The unique, "quick-opening" clamp design uses a standard O-ring.

#### STANDARD BENEFITS

- Low pressure drop
- Permanently piped housings are opened without disturbing the piping or requiring tools
- Quick-opening, clamp-type cover
- Carbon or stainless steel housings
- Adjustable-height tripod legs
- Holds 5 cartridge elements
- Accommodates cartridge elements in four lengths: 10", 20", 30", 40"
- 125-psi rated housing
- 3/4-inch clean-dirty/gage ports
- 2-inch female NPT ports
- V posts or threaded-center posts
- Standard hardware V-post and spring seals are 316 stainless steel.
- O-ring seals: Buna N, EPR, Viton®

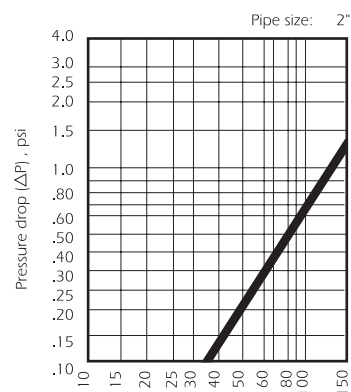

**\*Based on housing only. Fluid viscosity, filter cartridge used, and expected dirt loading should be considered when sizing a filter.**



## How To Order

### Reduced Pressure Model 8 Cartridge Housing

Build an ordering code as shown in the example

	Housing	Options
<b>Example:</b>	<b>8520</b>	<b>2P 1 125 S B 222</b>
<b>REDUCED PRESSURE MODEL 8 CARTRIDGE HOUSING</b> = 8		
<b>NUMBER OF CARTRIDGES</b> 5 = 5		
<b>CARTRIDGE LENGTH</b> 10 inch = 10 20 inch = 20 30 inch = 30 40 inch = 40		
<b>PIPE SIZE</b> 2-inch female NPT = 2P		
<b>OUTLET STYLE</b> Bottom = 1		
<b>PRESSURE RATING</b> 125 PSI = 12		
<b>HOUSING MATERIAL</b> Carbon Steel = C 304 Stainless Steel = S		
<b>COVER SEAL</b> Buna N = B Ethylene Propylene = E Viton® Fluorelastomer = V		
<b>CARTRIDGE DESIGN<sup>1</sup></b> 222 = 222 Single-open End = SOE Double-open End <sup>2</sup> = DOE		

1. Comes with V-Posts and spring seals.

### Dimensions (IN)

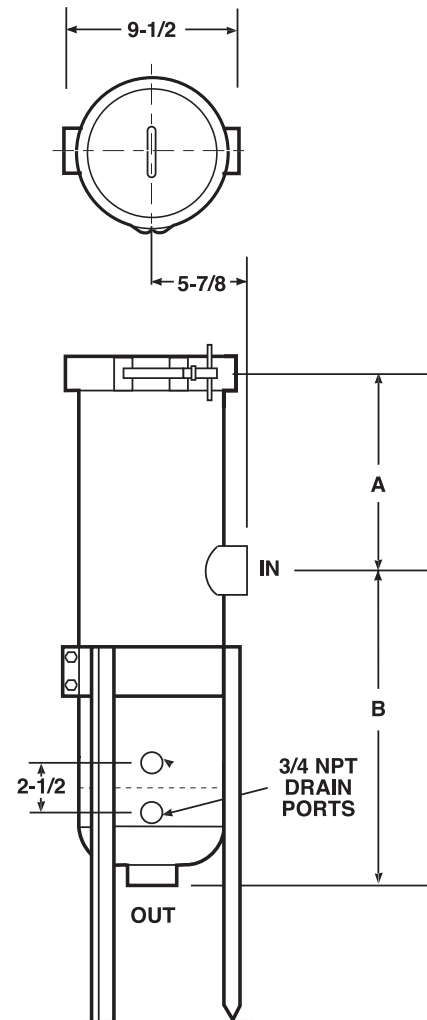

Cart. Length	A	B
10	6	14-13/16
20	11	19-13/16
30	16	24-13/16
40	21	29-13/16

Dimensions are reference only and should not be used for hard plumbing. Consult factory for certified drawings.



## SINGLE-CARTRIDGE LIQUID VESSELS

### Uniflow Series

Uniflow Series Cartridge Vessels are designed with a single compression ring which allows for easy-access and use in a wide variety of applications. The vessels are constructed of 304 or 316 stainless steel, are rated at 300 PSI, and feature dual seal o-rings to ensure against leaks. The Uniflow is available with 3/4" and 1" FNPT connections to accept DOE or -222 end cartridges in 10", 20", & 30" lengths.

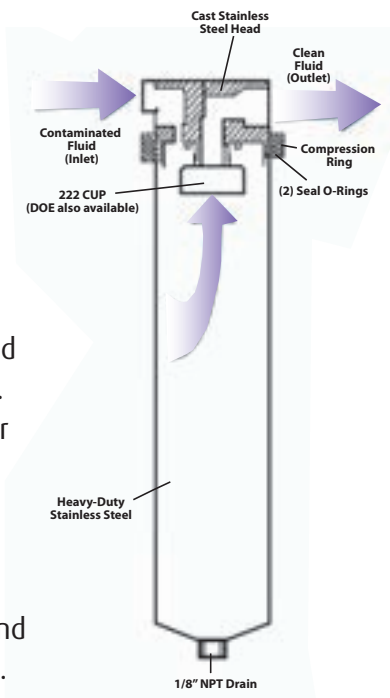

## UNIFLOW SERIES



### BENEFITS

- **Inline design for easy installation**
- **Single compression ring seal for easy change-out (wrench included)**
- **304 or 316 stainless steel construction**
- **300 PSI pressure rating**
- **Offered in double open-end or -222/FLAT configurations**
- **Heavy-duty cast head with mounting bracket**
- **Dual o-ring closure seal (silicone standard)**
- **1/8" drain and vent standard on all models**

### TYPICAL APPLICATIONS

- **Petrochemical**
- **Coolants**
- **Process Water**
- **Compressed air**
- **Solvents**
- **Hydraulic oils**
- **Potable liquids**

### OPTIONS

- **Other seal materials**

### ORDERING INFORMATION

UniFlow	Pressure rating	Length	Inlet/Outlet Size	Material	End Configuration
UF	3= 300 PSI	10= 10"	75N= 3/4" FNPT	A= 304 SS	D= DOE
		20= 20"	1N= 1" FNPT	S= 316 SS	2= 222/Flat
		30= 30"			



# Single-Bag Filter Features

## BAG VESSELS

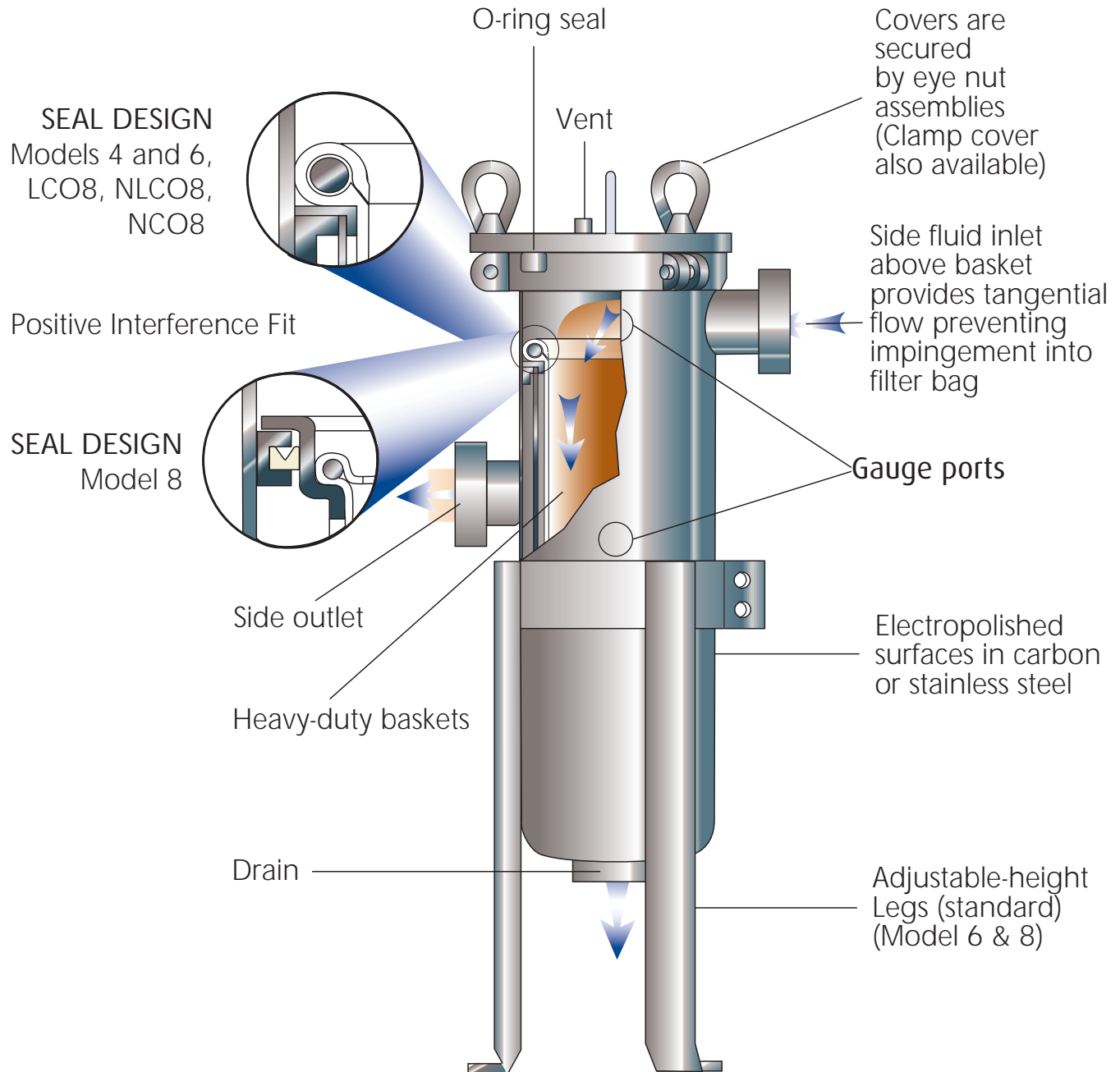

Typical Filter

## BAG VESSELS

## Model 4 Basket Strainer and Bag Filters

### Strainers or Bag Filters: YOUR CHOICE!

Model 4 strainer/filter housings are made in 2 sizes and 4 pressure ratings. In all cases, covers are easily removed without special tools, and the basket or bag is easily cleaned or replaced.

### BENEFITS AND OPTIONS

#### BENEFITS

- Low pressure drops
- Permanently piped housings
- Covers are O-ring sealed
- Carbon steel, or stainless steel (304 or 316) construction for housings
- All housings are electropolished to resist adhesion of dirt and scale
- Easy to clean!
- Adjustable-height legs, optional
- O-ring seals: Buna N, EPR, Viton®, Teflon®
- ASME code stamp available on select models
- Liquid displacers for easier servicing
- Four pressure ratings: 200 psi (with clamp cover) and 150, 300, or 500 psi (with eyenut cover)
- Duplex units are available
- Pipe sizes 3/4 thru 2-inch, NPT or flanged (standard 150 class flange)
- Two basket depths: 6, or 12 inches (nominal)

#### OPTIONS

- Bag filter hold-down devices
- Sanitary construction
- Different outlet connections
- Higher pressure ratings
- Extra-length legs
- Heat jacketing
- Epoxy coating
- Displacers
- Magnets



Covers are secured by three eyenut assemblies. One of them acts as a hinge, when the cover is opened.



### CHOOSING A BASKET STRAINER OR BAG FILTER

Choose between straining (removing particles down to 74 micron size) or filtering a fluid (removing particles down to 1 micron). This will direct you to choose the correct basket when ordering.

### OPERATION

Unfiltered liquid enters the housing above the bag or basket and flows through. Solids are contained inside the bag or basket, where they're easily and completely removed when the unit is serviced.

Fluid bypass around the basket is prevented because the filter bag seals radially against the housing inside diameter. A single cover gasket is used to seal the opening, and covers can be installed and removed without tools.

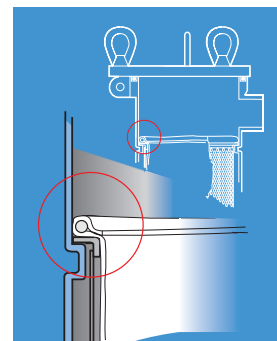

# Pressure Drop Data

## BAG VESSELS

Basket strainers and bag filters are usually selected so that the pressure drop does not exceed 2 psi when they are clean. Higher pressure drops may be tolerated when contaminant loading is low. Bag change-out should occur at 15 psid.

The pressure drop data is accurate for all housings with strainer or bag filter baskets. When filter bags are added, total pressure drop becomes the sum of the pressure drop as determined by the steps below.

### Follow these easy steps:

1. Using the desired pipe size and approximate flow rate, determine the basic pressure drop from the appropriate graph.
2. Multiply the pressure drop obtained in step 1 by the viscosity correction factor found in the accompanying table. This is the adjusted (clean) pressure drop for all baskets, without filter bags.
3. Add the pressure drop for the bag filter.



Clamp covers to the left and center, and eyenut cover to the right.

Bag Style and	Viscosity, cps								
	1 (H <sub>2</sub> O)	50	100	200	400	600	800	1000	2000
All unlined baskets	.65	.85	1.00	1.10	1.20	1.40	1.50	1.60	1.80
40-mesh lined	.73	.95	1.20	1.40	1.50	1.80	1.90	2.00	2.30
60-mesh lined	.77	1.00	1.30	1.60	1.70	2.10	2.20	2.30	2.80
80-mesh lined	.93	1.20	1.50	1.90	2.10	2.40	2.60	2.80	3.50
100-mesh lined	1.00	1.30	1.60	2.20	2.40	2.70	3.00	3.30	4.40
200-mesh lined	1.30	1.70	2.10	3.00	3.40	3.80	4.40	5.00	6.80

### BASKET DATA

Depth Nominal (inches)	Diameter (inches)	Surface Area (sq. ft.)	Volume (cu. in.)	Bag Size No.
6	3.9	0.5	65	3
12	3.9	1.0	130	4

### MODEL 4-FOR FLOW RATES TO 50GPM\*

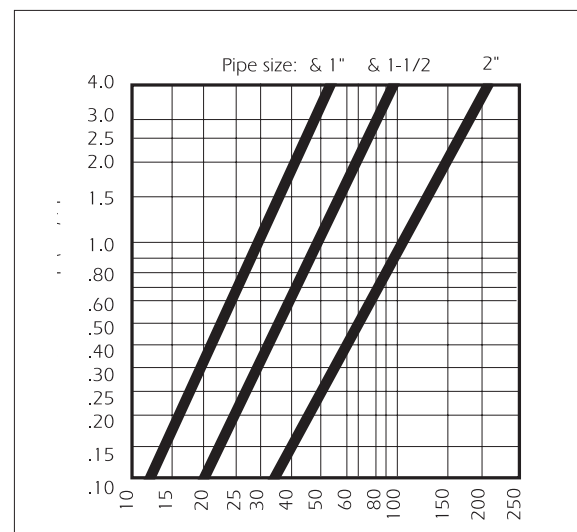

\*Based on housing only. Fluid viscosity, bag filter used, and expected dirt loading should be considered when sizing a filter.

# BAG VESSELS

## Dimensions (IN)

### Cover Types

#### EYENUT COVER

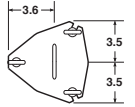

ANSI flanged connections and 500 Series with pipe threads

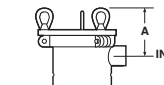

A clearance distance equal to basket depth must be available above housing for basket removal.

Legs for Model 4 are optional at extra cost.



#### CLAMP COVER



Rated 200 psi with NPT connections

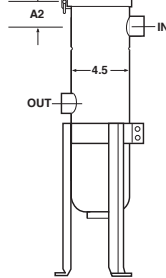

## Outlet Styles

Flanged  
(150 lb. ANSI)

Threaded  
(NPT)

### STYLE 1

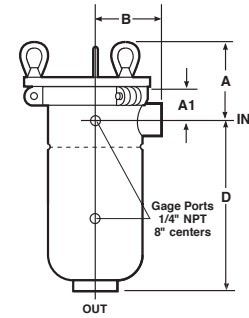
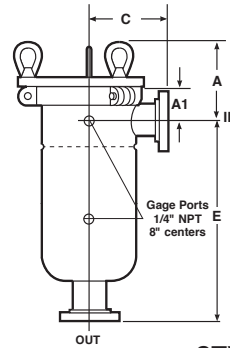

### STYLE 2

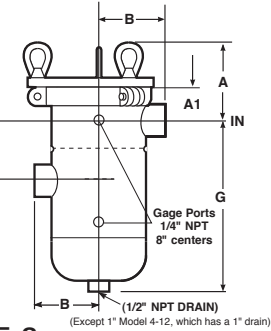
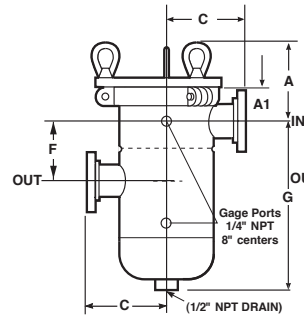

### STYLE 3

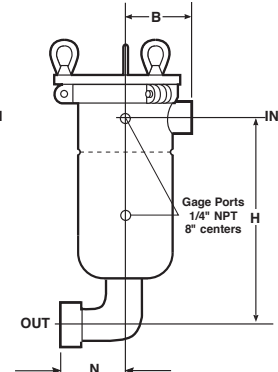
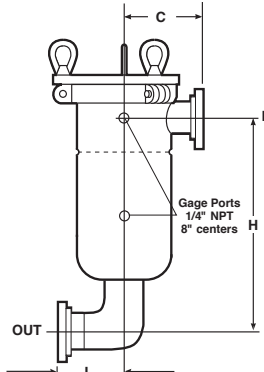

(Style 1 with customer's elbow)

## Dimensions (IN)

Model	Pipe Size	A	A1	A2	B	C	D	E	F	G	H	L	N
4-6	3/4	5.5	1.9	2.3	3.5	5.0	10.0	12.0	4.5	10.1	10.5	4.0	2.0
	1	5.5	1.9	2.3	3.5	5.0	10.0	12.0	4.5	10.1	10.9	4.0	2.5
	1-1/4	6.1	2.5	2.9	3.5	5.0	9.4	12.0	4.5	9.5	10.6	4.0	2.9
	1-1/2	6.1	2.5	2.9	3.5	5.0	9.4	12.0	4.5	9.5	10.9	4.0	3.3
	2	6.1	2.5	2.9	3.5	5.0	9.3	12.0	4.5	9.5	11.6	5.0	4.0
4-12	3/4	5.5	1.9	2.3	3.5	5.0	16.0	18.0	4.5	16.1	16.5	4.0	2.0
	1	5.5	1.9	2.3	3.5	5.0	16.0	18.0	4.5	16.1	16.9	4.0	2.5
	1-1/4	6.1	2.5	2.9	3.5	5.0	15.4	18.0	4.5	15.5	16.6	4.0	2.9
	1-1/2	6.1	2.5	2.9	3.5	5.0	15.4	18.0	4.5	15.5	16.9	4.0	3.3
	2	6.1	2.5	2.9	3.5	5.0	16.3	18.0	4.5	15.5	17.6	5.0	4.0

Dimensions are reference only and should not be used for hard plumbing. Consult factory for certified drawings.



# How To Order

Build an ordering code as shown in the example

	HOUSING					OPTIONS						
<b>Example:</b>	<b>4</b>	<b>12</b>	<b>2P</b>	<b>1</b>	<b>50</b>	<b>C</b>	<b>B</b>	<b>S</b>	<b>M</b>	<b>200</b>	<b>D</b>	<b>C</b>
<b>MODEL NO.</b>											<b>ASME CODE STAMP</b>	
4 = 4											C = Code	
LCO 4 = LCO 4											<b>DISPLACER</b>	
											D = Displacer	
<b>HOUSING SIZE</b>											<b>BASKET, MEDIA SIZE</b>	
6 inch = 6											No symbol if type B basket was selected	
12 inch = 12											Perforation diameters (for type P baskets) 1/4, 3/16, 9/64, 3/32, 1/16	
											Mesh sizes (for type M and BM baskets) 20, 30, 40, 50, 60, 70, 80, 100, 150, 200	
<b>PIPE SIZE, NPT and FLANGED<sup>1</sup></b>											<b>BASKET TYPE</b>	
3/4-in. female NPT = 3/4P											PB = Filter bag basket, 9/64 perforations <sup>3</sup>	
1-in. female NPT = 1P											P = Strainer basket, perforated metal	
1-1/4-in. female NPT = 1-1/4P											BM = Filter bag basket, perforated, mesh lined <sup>3</sup>	
1-1/2-in. female NPT = 1-1/2P											M = Strainer basket, perforated, mesh lined with spring handle	
2-in. female NPT = 2P											HWM = Filter bag basket, heavy wire mesh <sup>3</sup>	
3/4-in. 150 class ANSI flange = 3/4F											<b>BASKET SEAL</b>	
1-in. 150 class ANSI flange = 1F											N = No seal (with bag type baskets)	
1-1/4-in. 150 class ANSI flange = 1-1/4F											S = Seal required (on strainer type baskets)	
1-1/2-in. 150 class ANSI flange = 1-1/2F											<b>COVER SEAL</b>	
2-in. 150 class ANSI flange = 2F											B = Buna N	
											E = Ethylene Propylene	
<b>OUTLET STYLE</b>											<b>Eyenuit Cover Only</b>	
Bottom = 1											V = Viton® Fluoroelastomer	
Side = 2											TV = Teflon® Encapsulated Viton®	
Bottom elbow = 3											TW = Teflon® (solid white)	
<b>PRESSURE RATING<sup>2</sup></b>												
150 psi (flanged) = 15												
200 psi (NPT) (LCO 4 only) = 20												
300 psi (flanged) = 30												
500 psi (NPT) = 50												
<b>HOUSING MATERIAL</b>												
Carbon steel = C												
304 stainless steel = S												
316 stainless steel = S6												

- Flanges provided with the housing match the pressure rating of the vessel. Housings rated 150 psi have 150 class flanges. Housings rated 300 psi have 300 class flanges. ANSI B16.5 Pressure-Temperature rating tables determine flange class for ASME code housings. Consult factory.
- Higher pressure ratings available. Consult factory.
- 150 psi unit has 150 class flanges. 300 psi unit has 300 class flanges. 200 and 500 unit available in NPT only.

## Model 6 Basket Strainer and Bag Filters

### Strainers or Bag Filters: YOUR CHOICE!

Model 6 strainer/filter housings are made in 3 sizes and 3 pressure ratings, and can serve as basket strainers (for particle retention down to 74 micron size) or as bag filters (for particle retention down to 1 micron size). In all cases, covers are easily removed without special tools, and the basket or bag is easily cleaned or replaced.

### BENEFITS AND OPTIONS

#### BENEFITS

- Low pressure drops
- Permanently piped housings
- Covers are O-ring sealed
- Carbon steel, or stainless steel (304 or 316) construction for housings
- All housings are electropolished to resist adhesion of dirt and scale
- Easy to clean!
- Adjustable-height legs, standard
- O-ring seals: Buna N, EPR, Viton<sup>®</sup>, Teflon<sup>®</sup>
- ASME code stamp available
- Three pressure ratings: 150, 210 or 300 psi
- Duplex units are available
- Can provide 3.4 square feet of basket or bag surface area without need for ASME code construction
- Three basket depths: 12, 18, or 30 inches (nominal)
- Special alloys

#### OPTIONS

- Sanitary construction
- Different outlet connections
- Higher pressure ratings
- Extra-length legs
- Heat jacketing
- Liquid displacers for easier servicing



Covers are secured by three eye-nut assemblies. One of them acts as a hinge, when the cover is opened.

### CHOOSING A BASKET STRAINER OR BAG FILTER

Choose between straining (removing particles down to 74 micron size) or filtering a fluid (removing particles down to 1 micron). This will direct you to the correct basket when ordering.

### OPERATION

Unfiltered liquid enters the housing above the bag or basket and passes down through them. Solids are contained inside the bag or basket, where they are easily and completely removed when the unit is serviced.

Fluid bypass around the basket is prevented because the outside diameter of the filter bag seals against the housing inside diameter.

A single cover gasket is used to seal the opening, and covers can be installed and removed without tools.

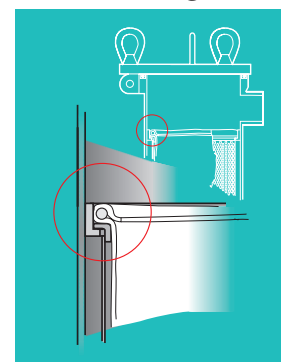

# Pressure Drop Data

## BAG VESSELS

Basket strainers and bag filters are usually selected so that the pressure drop does not exceed 2 psi, when they are clean. Higher pressure drops may be tolerated, when contaminant loading is low. Bag change should occur at 15psid.

The pressure drop data is accurate for all housings with strainer or bag filter baskets. When bag filters are added, total pressure drop becomes the sum of the pressure drop as determined by the steps below.

### Follow these easy steps:

1. Using the desired pipe size and approximate flow rate, determine the basic pressure drop from the appropriate graph.
2. Multiply the pressure drop obtained in step 1 by the viscosity correction factor found in the accompanying table. This is the adjusted (clean) pressure drop for all baskets, without bag filters.
3. Add the pressure drop for the bag filter.

	Viscosity, cps								
	1 (H <sub>2</sub> O)	50	100	200	400	600	800	1000	2000
All unlined baskets	.65	.85	1.00	1.10	1.20	1.40	1.50	1.60	1.80
40-mesh lined	.73	.95	1.20	1.40	1.50	1.80	1.90	2.00	2.30
60-mesh lined	.77	1.00	1.30	1.60	1.70	2.10	2.20	2.30	2.80
80-mesh lined	.93	1.20	1.50	1.90	2.10	2.40	2.60	2.80	3.50
100-mesh lined	1.00	1.30	1.60	2.20	2.40	2.70	3.00	3.30	4.40
200-mesh lined	1.30	1.70	2.10	3.00	3.40	3.80	4.40	5.00	6.80

### BASKET DATA

Depth Nominal (inches)	Diameter (inches)	Surface Area (sq. ft.)	Volume (cu. in.)	Bag Size No.
12	5	1.3	235	7
18	5	2.0	350	8
30	5	3.4	630	9

### Model 6-For flow rates to 100 gpm\*

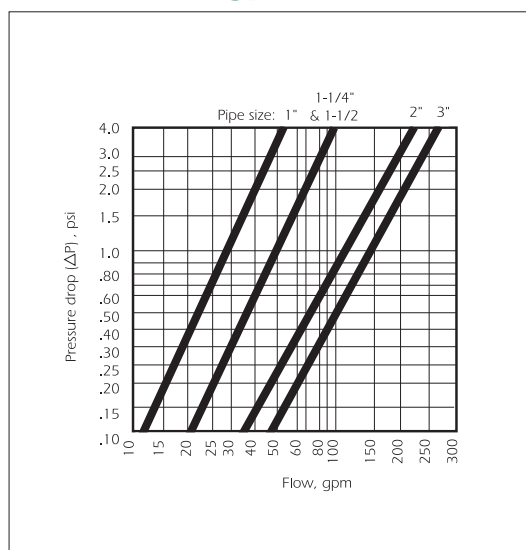

\*Based on housing only. Fluid viscosity, bag filter used, and expected dirt loading should be considered when sizing a filter.



Eye-catchers with bag filter and basket or basket strainer.



# BAG VESSELS

## Dimensions (IN)

### Cover Types

#### EYENUT COVER

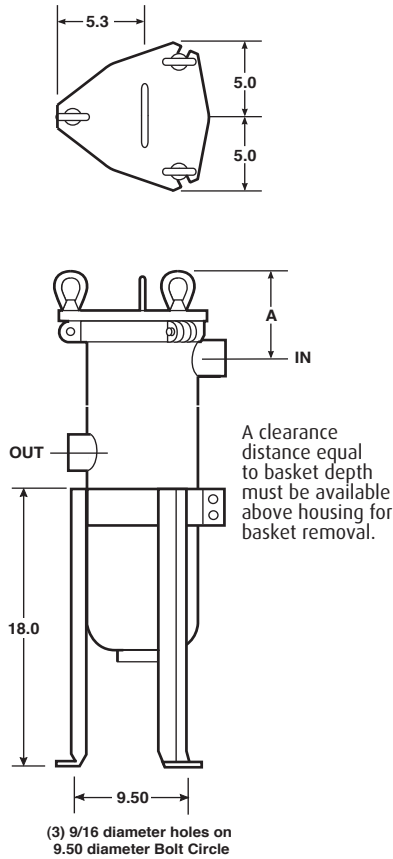

## Outlet Styles

Flanged  
(150 lb. ANSI)

Threaded  
(NPT)

### STYLE 1

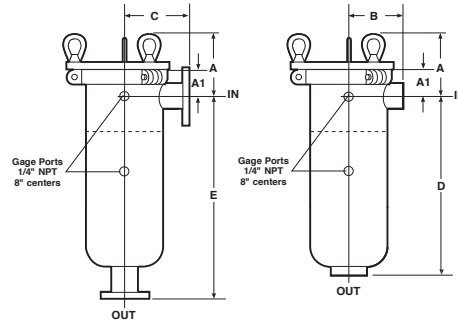

### STYLE 2

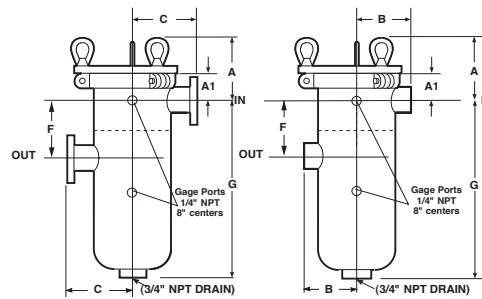

### STYLE 3

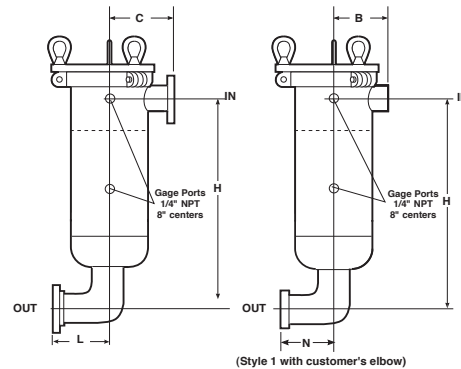

## Dimensions (IN)

Model	Pipe Size	A	A1	B	C	D	E	F	G	H	L	N
6-12	1	6.3	2.5	4.3	6.0	17.6	19.0	4.3	17.4	18.1	5.0	2.5
	1-1/4	6.3	2.5	4.3	6.0	17.6	19.0	4.7	17.4	18.4	5.0	2.9
	1-1/2	6.3	2.5	4.3	6.0	17.6	19.0	4.7	17.4	18.8	5.0	3.3
	2	7.1	3.4	4.3	6.0	16.6	19.0	6.6	16.5	18.6	5.0	4.0
	3	7.1	3.4	4.3	6.0	17.0	19.0	6.6	16.5	19.9	7.3	6.1
6-18	1	6.3	2.5	4.3	6.0	22.8	24.3	4.3	22.7	23.3	5.0	2.5
	1-1/4	6.3	2.5	4.3	6.0	22.8	24.3	4.7	22.7	23.7	5.0	2.9
	1-1/2	6.3	2.5	4.3	6.0	22.8	24.3	4.7	22.7	24.0	5.0	3.3
	2	7.1	3.4	4.3	6.0	21.8	24.3	6.6	21.8	23.8	5.0	4.0
	3	7.1	3.4	4.3	6.0	22.3	24.3	6.6	21.8	25.3	7.3	6.1
6-30	1	6.3	2.5	4.3	6.0	32.8	34.3	4.3	32.7	33.3	5.0	2.5
	1-1/4	6.3	2.5	4.3	6.0	32.8	34.3	4.7	32.7	33.7	5.0	2.9
	1-1/2	6.3	2.5	4.3	6.0	32.8	34.3	4.7	32.7	34.0	5.0	3.3
	2	7.1	3.4	4.3	6.0	31.8	34.3	6.6	31.8	33.8	5.0	4.0
	3	7.1	3.4	4.3	6.0	32.3	34.3	6.6	31.8	35.3	7.3	6.1

Dimensions are reference only and should not be used for hard plumbing. Consult factory for certified drawings.



# How To Order

Build an ordering code as shown in the example

## BAG VESSELS

**Example:** 6 30 3P 1 30 C B S M 200 D C

**MODEL NO.**  
6 = 6

**HOUSING SIZE**  
12 inch = 12  
18 inch = 18  
30 inch = 30

**PIPE SIZE, NPT and FLANGED<sup>1</sup>**  
3/4-in. female NPT = 3/4P  
1-in. female NPT = 1P  
1-1/4-in. female NPT = 1-1/4P  
1-1/2-in. female NPT = 1-1/2P  
2-in. female NPT = 2P  
3-in. female NPT = 3P  
3/4-in. 150 class ANSI flange = 3/4F  
1-in. 150 class ANSI flange = 1F  
1-1/4-in. 150 class ANSI flange = 1-1/4F  
1-1/2-in. 150 class ANSI flange = 1-1/2F  
2-in. 150 class ANSI flange = 2F  
3-in. 150 class ANSI flange = 3F

**OUTLET STYLE**  
Bottom = 1  
Side = 2  
Bottom elbow = 3

**PRESSURE RATING<sup>2</sup>**  
150 psi (flanged or NPT) = 15  
210 psi (flanged or NPT) = 21  
300 psi (flanged or NPT) = 30

**HOUSING MATERIAL**  
Carbon steel = C  
304 stainless steel = S  
316 stainless steel = S6

**ASME CODE STAMP**  
C = Code  
NSF = NSF 61 listed

**DISPLACER**  
D = Displacer

**BASKET, MEDIA SIZE**  
No symbol if type B basket was selected  
Perforation diameters (for type P baskets) 1/4, 3/16, 9/64, 3/32, 1/16  
Mesh sizes (for type M and BM baskets) 20, 30, 40, 50, 60, 70, 80, 100, 150, 200

**BASKET TYPE**  
PB = Filter bag basket, 9/64 perforations<sup>3</sup>  
P = Strainer basket, perforated metal  
BM = Filter bag basket, perforated, mesh lined<sup>3</sup>  
M = Strainer basket, perforated, mesh lined  
HWM = Filter bag basket, heavy wire mesh<sup>3</sup>

**BASKET SEAL**  
N = No seal (never on Models 4 & 6 bag-type baskets)  
S = Seal required (always on Model 8 bag-type baskets)

**COVER SEAL**  
B = Buna N  
E = Ethylene Propylene  
V = Viton® Fluoroelastomer  
TV = Teflon® Encapsulated Viton®  
TW = Teflon® (solid white)

- Flanges provided with the housing match the pressure rating of the vessel. Housings rated 150 psi have 150 class flanges. Housings rated 300 psi have 300 class flanges. ANSI B16.5 Pressure-Temperature rating tables determine flange class for ASME code housings. Consult factory.
- Higher pressure ratings available. Consult factory.
- 150 psi unit has 150 class flanges. 300 psi unit has 300 class flanges. 210 psi unit available only in NPT.

## BAG VESSELS

## Model 8 Basket Strainer and Bag Filters

### Strainers or Bag Filters:

## YOUR CHOICE!

Model 8 strainer/filter housings are made in 2 sizes and 2 pressure ratings, and can serve as basket strainers (for particle retention down to 74 micron size) or as bag filters (for particle retention down to 1 micron size). In all cases, covers are easily removed, without tools, and the basket or bag is easily cleaned or replaced.

### BENEFITS AND OPTIONS

#### BENEFITS

- NSF 61 listed
- Low pressure drops
- Permanently piped housings
- Covers are O-ring sealed
- Carbon steel, or stainless steel (304 or 316) construction for housings
- All housings are electropolished to resist adhesion of dirt and scale
- Easy to clean!
- Adjustable-height legs, standard
- Large-area, heavy-duty baskets
- O-ring seals: Buna N, EPR, Viton®, Teflon®
- ASME code stamp available
- Two pressure ratings: 150 and 300
- Duplex units are available
- Pipe sizes 3/4 thru 6-inch, NPT or flanged
- Two basket depths: 15 or 30 inches (nominal)



#### OPTIONS

- Sanitary construction
- Different outlet connections
- Higher pressure ratings
- Extra-length legs
- Heat jacketing
- Adapters for holding filter cartridges.
- Liquid displacers for easier servicing
- Can be fitted with an adapter to hold cartridge filter elements



### CHOOSING A BASKET STRAINER OR BAG FILTER

Choose between straining (removing particles down to 74 micron size) or filtering a fluid (removing particles down to 1 micron). This will direct you in selecting the correct basket when ordering.

### Dual Stage Straining/Filter

All Matrix Model 8 housings can be supplied with a second, inner basket, which is supported on the top flange of the regular basket. Both baskets can be strainers (with or without wire mesh linings) or both can be baskets for filter bags. They can also be mixed: one a strainer basket, the other a filter bag basket. Dual-stage action will increase strainer or filter life and reduce servicing needs.



## Operation

Unfiltered liquid enters the housing above the bag or basket and flows through. Solids are contained inside the bag or basket, where they are easily removed when the unit is serviced. A basket bail is pushed down by the closed cover to hold the basket against a positive stop in the housing. A radial seal prevents bypass of unfiltered liquid.

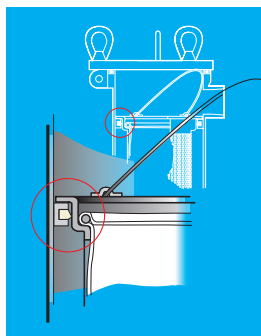

### PRESSURE DROP DATA

Basket strainers and bag filters are usually selected so that the pressure drop does not exceed 2 psi, when they are clean. Higher pressure drops may be tolerated, when contaminant loading is low. Bag change occurs at 15psid.

The pressure drop data is accurate for all housings with strainer or filter bag baskets. When filter bags are added, total pressure drop becomes the sum of the pressure drop as determined by the steps below.

### Follow these easy steps:

1. Using the desired pipe size and approximate flow rate, determine the basic pressure drop from the appropriate graph.
2. Multiply the pressure drop obtained in step 1 by the viscosity correction factor found in the accompanying table. This is the adjusted (clean) pressure drop for all baskets without filter bags.
3. Add the pressure drop for the bag.

### BASKET DATA

Depth Nominal (inches)	Diameter (inches)	Surface Area (sq. ft.)	Volume (cu. in.)	Bag Size No.
15	6.7	2.3	500	1
30	6.7	4.4	1000	2

## BAG VESSELS

	Viscosity, cps								
	1 (H <sub>2</sub> O)	50	100	200	400	600	800	1000	2000
All unlined baskets	.65	.85	1.00	1.10	1.20	1.40	1.50	1.60	1.80
40-mesh lined	.73	.95	1.20	1.40	1.50	1.80	1.90	2.00	2.30
60-mesh lined	.77	1.00	1.30	1.60	1.70	2.10	2.20	2.30	2.80
80-mesh lined	.93	1.20	1.50	1.90	2.10	2.40	2.60	2.80	3.50
100-mesh lined	1.00	1.30	1.60	2.20	2.40	2.70	3.00	3.30	4.40
200-mesh lined	1.30	1.70	2.10	3.00	3.40	3.80	4.40	5.00	6.80

### MODEL 8-FOR FLOW RATES TO 220 GPM\*

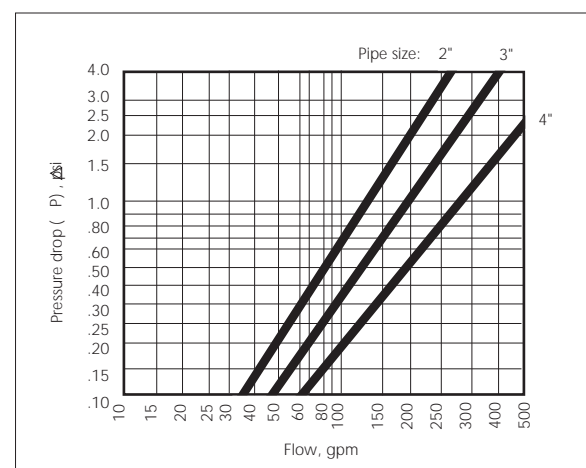

\*Based on housing only. Fluid viscosity, filter bag used, and expected dirt loading should be considered when sizing a filter.



Eyenuit covers with filter bag and basket.

**BAG VESSELS**

**Dimensions (IN)**

**Outlet Styles**

Flanged  
(150 lb. ANSI)

Threaded  
(NPT)

**Outlet Styles**

Flanged  
(300 lb. ANSI)

Threaded  
(NPT)

**STYLE 1**

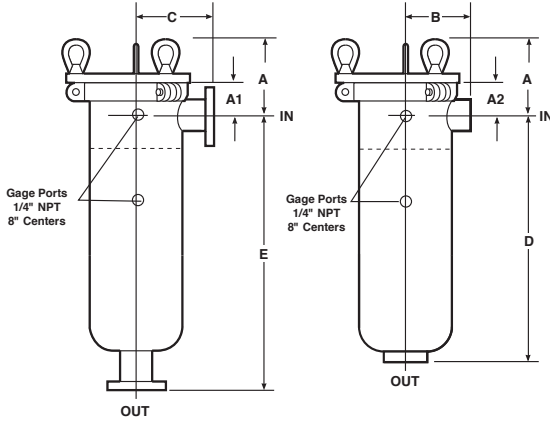

**STYLE 1**

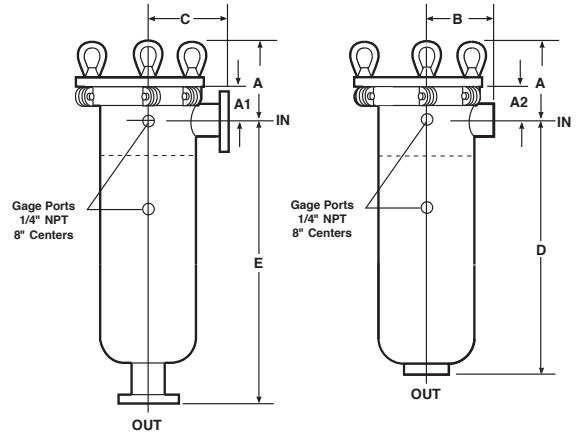

**STYLE 2**

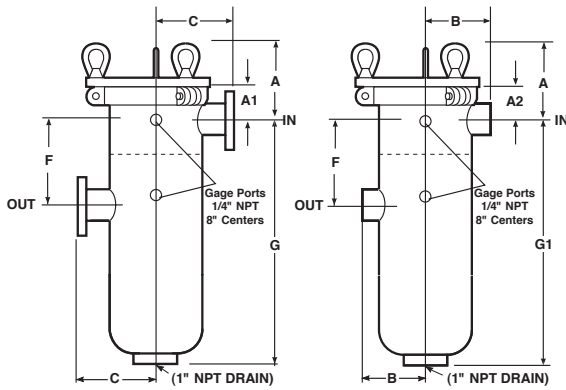

**STYLE 2**

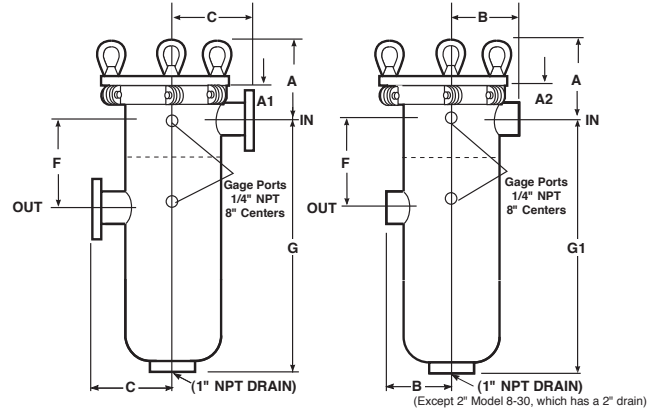

**STYLE 3**

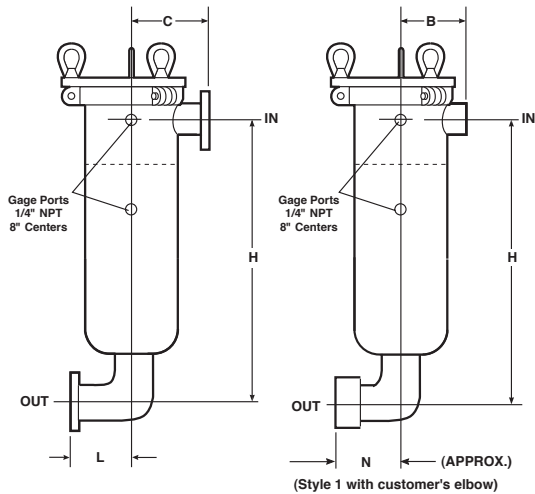

**STYLE 3**

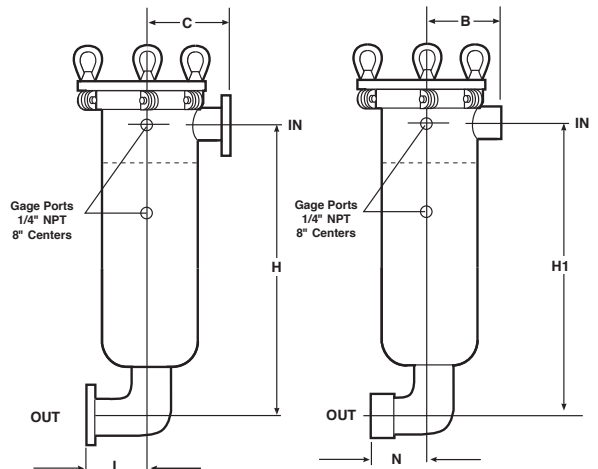

## BAG VESSELS

## Cover Types

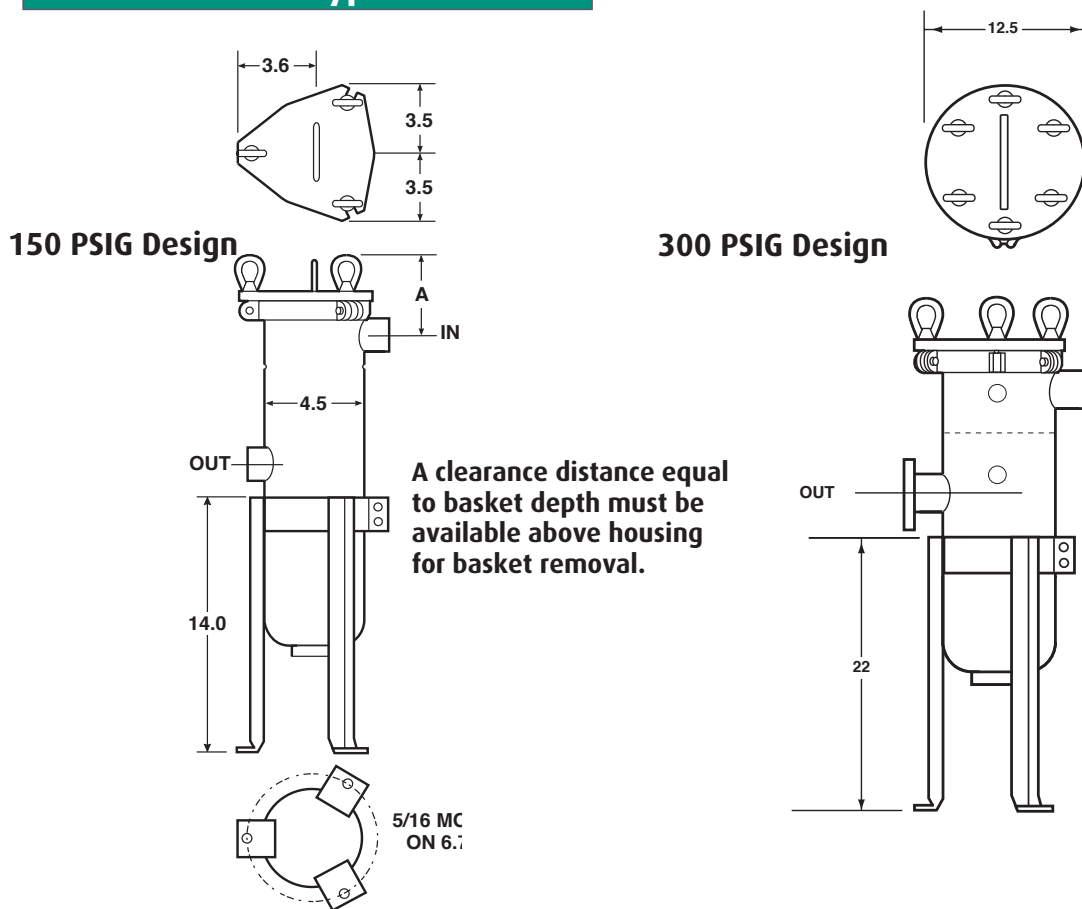

## Dimensions (IN) 150 PSIG Design

Model	Pipe Size	A	A1	A2	B	C	D	E	F	G/G1	H/H1	J	K
8-15	2	9.1	5.4	2.9	5.9	7.5	20.6	23.4	8.0	20.9	22.8	5.0	4.06
	3	9.1	5.4	3.7	6.8	7.5	21.3	23.4	8.0	20.9	24.3	7.25	6.12
	4	9.1	5.4	5.0	6.8	8.6	21.3	23.9	8.0	20.9	25.6	9.0	7.75
	6	9.4	5.6	5.9	7.1	8.6	23.6	27.1	9.0	23.4	30.9	12.5	11.0
8-30	2	9.1	5.4	2.9	5.9	7.5	35.6	38.4	8.0	35.9	37.8	5.0	4.06
	3	9.1	5.4	3.7	6.8	7.5	36.3	38.4	8.0	35.9	39.3	7.25	6.12
	4	9.1	5.4	5.0	6.8	8.6	36.3	38.9	8.0	35.9	40.6	9.0	7.75
	6	9.4	5.6	5.9	7.1	8.6	38.6	42.1	9.0	38.4	45.9	12.5	11.0

## Dimensions (IN) 300 PSIG Design

Model	Pipe Size	A	A1/A2	B	C	D	E	F	G/G1	H/H1	J	K
8-15	2	9.5	5.4	5.9	7.5	20.6	23.4	8.0	20.9	22.8	5.0	4.06
	3	9.5	5.4	6.8	8.6	21.3	23.4	8.0	20.9	24.3	7.25	6.12
	4	9.5	5.4	6.8	8.6	21.3	23.9	8.0	20.9	25.6	9.0	7.75
	6	9.6	5.6	7.1	8.6	23.6	27.1	9.0	23.4	30.9	12.5	11.0
8-30	2	9.5	5.4	5.9	7.5	35.6	38.4	8.0	35.9	37.8	5.0	4.06
	3	9.5	5.4	6.8	7.5	36.3	38.4	8.0	35.9	39.3	7.25	6.12
	4	9.5	5.4	6.8	8.6	36.3	38.9	8.0	35.9	40.6	9.0	7.75
	6	9.6	5.6	7.1	8.6	38.6	42.1	9.0	38.4	45.9	12.5	11.0

## BAG VESSELS

## How To Order

Build an ordering code as shown  
in the example

	HOUSING				OPTIONS				OPTIONAL INNER BASKET					
<b>Example:</b>	8	15	3P	1	15	C	B	S	M	200	D	C	2M	50
<b>MODEL NO.</b> 8 = 8														
<b>HOUSING SIZE</b> 15 inch = 15 30 inch = 30														
<b>PIPE SIZE, NPT and FLANGED<sup>1</sup></b> 3/4-in. female NPT = 3/4P 1-in. female NPT = 1P 1-1/4-in. female NPT = 1-1/4P 1-1/2-in. female NPT = 1-1/2P 2-in. female NPT = 2P 3-in. female NPT = 3P 3/4-in. 150 class ANSI flange = 3/4F 1-in. 150 class ANSI flange = 1F 1-1/4-in. 150 class ANSI flange = 1-1/4F 1-1/2-in. 150 class ANSI flange = 1-1/2F 2-in. 150 class ANSI flange = 2F 3-in. 150 class ANSI flange = 3F 4-in. 150 class ANSI flange = 4F 6-in. 150 class ANSI flange = 6F														
<b>OUTLET STYLE</b> Bottom = 1 Side = 2 Bottom elbow = 3														
<b>PRESSURE RATING<sup>2</sup></b> 150 psi (NPT or flanged) = 15 300 psi (NPT or flanged) = 30														
<b>HOUSING MATERIAL</b> Carbon steel = C 304 stainless steel = S 316 stainless steel = S6														
<b>COVER SEAL</b> Buna N = B Ethylene Propylene = E Viton® Fluoroelastomer = V Teflon® Encapsulated Viton® = TV Teflon® (solid white) (6 Bolt Cover) = TW <sup>5</sup>														
<b>BASKET SEAL</b> Seal required = S														
													<b>OPTIONAL INNER BASKET</b> 2M 50	
													<b>FOR MODEL 8 ONLY</b>	
													<b>OPTIONAL INNER BASKET, MEDIA SIZE-No symbol if type 2B basket was selected</b>	
													Perforation diameters (for type 2P baskets) 1/4, 3/16, 9/64, 3/32, 1/16	
													Mesh sizes (for type 2M and 2BM baskets) 20, 30, 40, 50, 60, 70, 80, 100, 150, 200	
													<b>OPTIONAL INNER BASKET TYPE</b>	
													2B = Filter bag basket, 9/94 perforations <sup>3</sup>	
													2P = Strainer basket, perforated metal	
													2BM = Filter bag basket, perforated, mesh lined <sup>3</sup>	
													2M = Strainer basket, perforated, mesh lined	
													<b>ASME CODE STAMP</b>	
													C = Code	
													NSF = NSF 61 listed	
													<b>DISPLACER</b>	
													D = Displacer	
													<b>BASKET, MEDIA SIZE-No symbol if type B basket was selected</b>	
													Perforation diameters (for type P baskets) 1/4, 3/16, 9/64, 3/32, 1/16	
													Mesh sizes (for type M and BM baskets) 20, 30, 40, 50, 60, 70, 80, 100, 150, 200	
													<b>BASKET TYPE</b>	
													PB = Filter bag basket, 9/64 perforations <sup>3</sup>	
													P = Strainer basket, perforated metal	
													BM = Filter bag basket, perforated, mesh lined <sup>3</sup>	
													M = Strainer basket, perforated, mesh lined	
													HWM = Filter bag basket, heavy wire mesh <sup>3</sup>	

**NOTE:**

- Flanges provided with the housing match the pressure rating of the vessel. Housings rated 150 psi have 150 class flanges. Housings rated 300 psi have 300 class flanges. ANSI B16.5 Pressure-Temperature rating tables determine flange class for ASME code housings. Consult factory.
- Higher pressure ratings available. Consult factory.
- 150 psi unit has 150 class flanges. 300 psi unit has 300 class flanges.
- 300 psi design only.

# Model NCO and NLCO Bag or Cartridge Filter Housings

## BAG VESSELS

### Low cost filter housings for flow rates to 100 gpm\*

NCO high-capacity bag filters offer an exceptional value in basic filtration applications offered in trade sizes 1, 2, and 12.

NCO housings provide large dirt-holding capacity combined with a rugged design rated to 150 psi. The housings incorporate an eyenut cover that is easily removed, reducing time spent on bag or cartridge change-out. The NCO bag housing offers versatility for any piping arrangement, utilizing our unistyle design (side and bottom outlet). Two connection sizes are available for both bag and cartridge filters.

The NCO housings are electropolished creating a smooth, easy-to-clean surface. A variety of filter bags or cartridges (rated 0.5 $\mu$  absolute to 100 $\mu$  nominal) can be utilized in this housing. Keep your filtration process cost effective without sacrificing quality.



### Benefits

- Permanently piped housings are opened without special tools
- Carbon or stainless steel housings
- Covers are O-ring sealed
- O-ring seals: Buna N, EPR and Viton®
- 150 psi rated housing
- Heavy-duty basket, over 50% open area
- Uses standard number 1, 2 or 12 size bags
- Filter selection surface area is:  
2.3 square feet (number 1 size bag),  
4.4 square feet (number 2 size bag),  
5.6 square feet (number 12 size bag)  
68 square feet (500 series cartridge)  
100 square feet (700 series cartridge)
- 1-1/2-inch or 2-inch NPT inlet and outlet
- 1/4-inch NPT vent connection
- Adjustable leg assembly

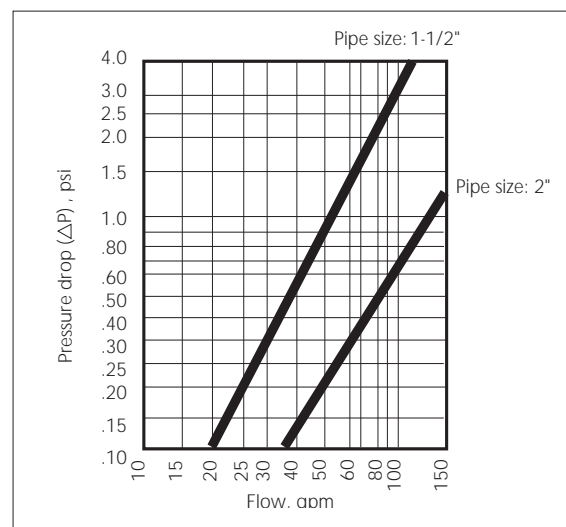

\*Based on housing only. Fluid viscosity, filter bag used, and expected dirt loading should be considered when sizing a filter.



## BAG VESSELS

## How To Order

Build an ordering code as shown  
in the example

Example :	Housing				Options		
	NC08	30	2P	* 15	C	B	PB
<b>MODEL</b> NC08 (#1, #2 bag)							
NLC08 (#12 bag)							
<b>BASKET SIZE</b> 15-inch (NCO only) = 15 30-inch (NCO or NLCO) = 30							
<b>PIPE SIZE</b> 1-1/2-inch female NPT = 1-1/2P 2-inch female NPT = 2P							
<b>OUTLET STYLE</b> Side/Bottom Unistyle (NCO or NLCO) = * Bottom = 1							
<b>PRESSURE RATING</b> 150 psi = 15							
<b>HOUSING MATERIAL</b> Carbon steel = C 304 Stainless steel = S							
<b>COVER SEAL</b> Buna N = B Ethylene propylene = E Viton® Fluoroelastomer = V							
<b>BASKET TYPE</b> Filter bag basket (NCO or NLCO) = PB							

1. Filter bags are specified separately.
2. Basket material is compatible with housing.
3. Weight (approximately): 70 lbs.



QUALITY SYSTEM  
REGISTERED TO  
ISO 9001:2004

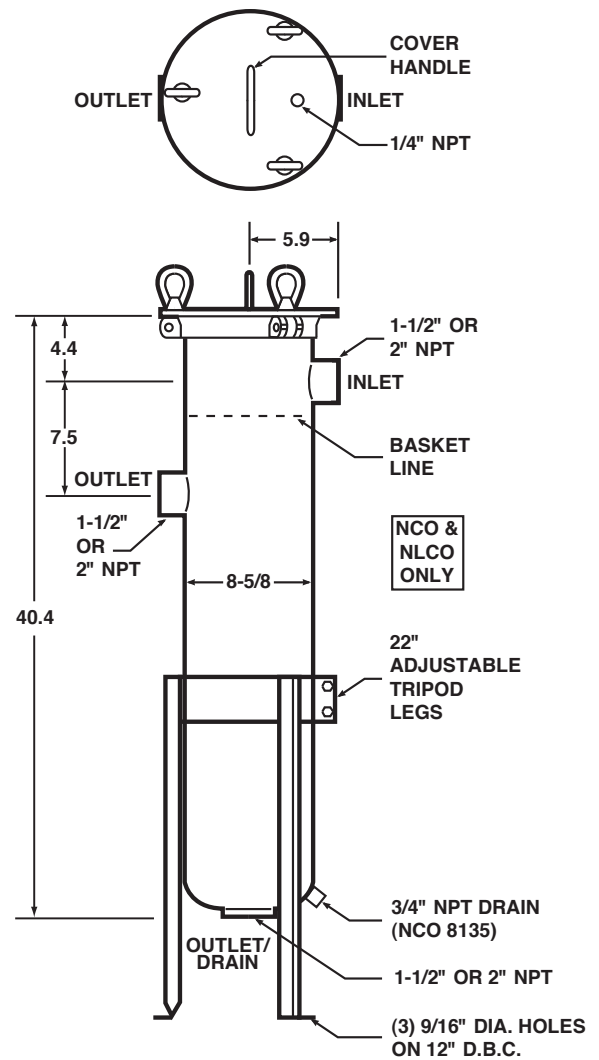

Dimensions are reference only and should not be used for hard plumbing. Consult factory for certified drawings.



## Model 8-125 psi Bag Filters

BAG VESSELS

Low cost filter housings for flow rates to 100 gpm\*

These high-capacity bag filters are very low in cost and offer large dirt holding capacity. These housings are made from carbon steel or stainless steel. They use a clamp cover that is easily removed, reducing time spent on bag change-out. The O-ring seal on the cover ensures a seal. This housing also utilizes our Unistyle design offering the option of a side or bottom outlet. There is a 2-inch outlet on the side with a 2-inch plugged drain at the bottom of the housing. The outlet can easily be changed to the bottom by merely moving the plug from the drain to the side outlet.

### Benefits

- Permanently piped housings are opened without special tools
- Quick opening cover
- Carbon or stainless steel housings
- Adjustable-height tripod legs
- O-ring seals: Buna N, EPR and Viton®
- 125-psi rated housing
- Basket material is compatible with housing
- Uses standard number 2 size bags and baskets
- Bag/Basket surface area is 4.4 square feet
- 2-inch NPT ports

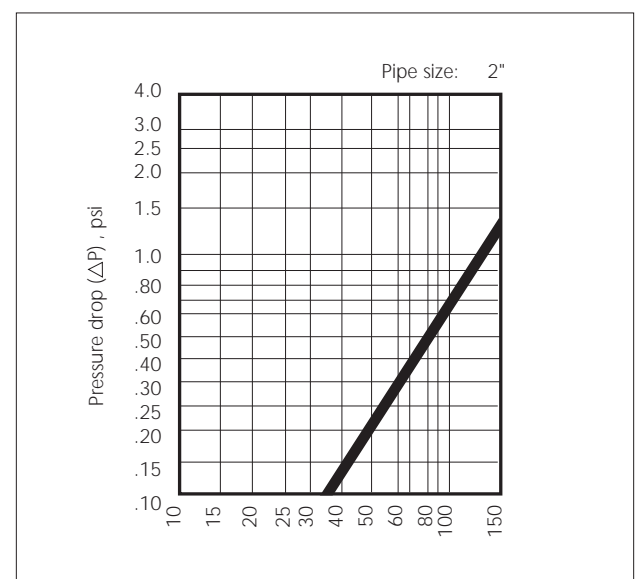

\*Based on housing only. Fluid viscosity, filter bag used, and expected dirt loading should be considered when sizing a filter.

## BAG VESSELS

## How To Order

Low Pressure  
Model 8 Housing

Build an ordering code as shown in the example

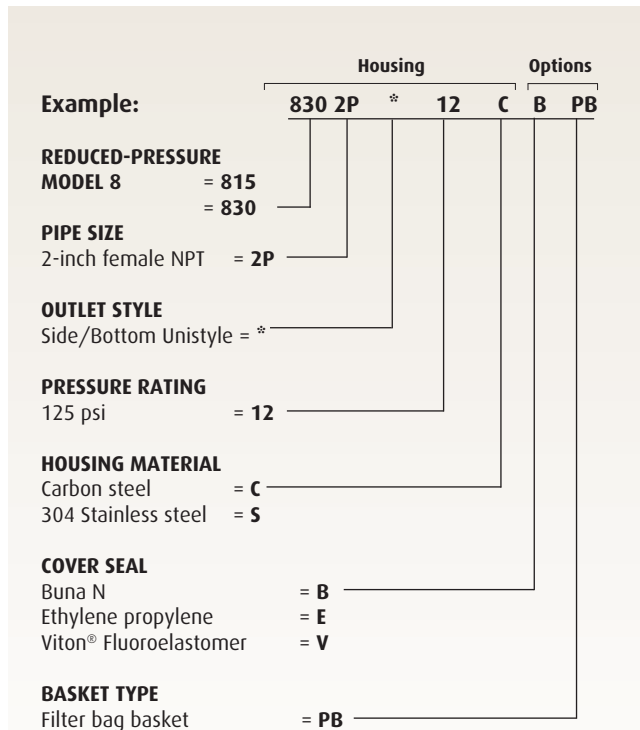

## Dimensions

Model	A
815	21.1
830	35.9

## Dimensions (IN)

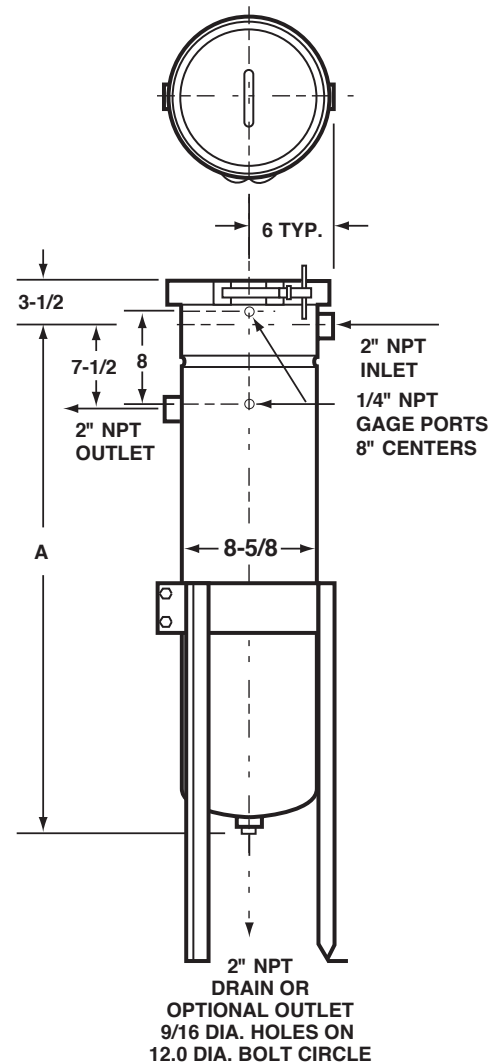

Dimensions are reference only and should not be used for hard plumbing. Consult factory for certified drawings.



# Model LCO Bag Filter Housings

## BAG VESSELS

Low cost filter housings for flow rates to 100 gpm\*

These high-capacity bag filters are low in cost and offer more dirt holding capacity. These housings are made from carbon steel or stainless steel. They use a clamp cover that is easily removed, reducing time spent on cleaning and bag replacement. Housings also utilize our Unistyle design offering you the option of a side or bottom outlet. There is a 1-1/2-inch or 2-inch inlet and outlet on the side, with a 1-1/2-inch or 2-inch plugged drain at the bottom of the housing. The outlet can easily be changed to the bottom by merely moving the plug from the drain to the side outlet.

### Benefits

- Permanently piped housings are opened without special tools
- Quick opening cover
- Carbon or stainless steel housings
- Large area bag and basket for greater dirt-holding capacity
- O-ring seals: Buna N, EPR and Viton®
- Adjustable-height tripod legs
- 125 psi rated housing
- Basket material is compatible with housing
- Bag surface area is 5.6 square feet (LCO8), and 2.0 square feet (LCO6)
- Uses number 12 size bags (LCO8), and number 8 size bags (LCO6)
- 2-inch NPT ports (LCO8)

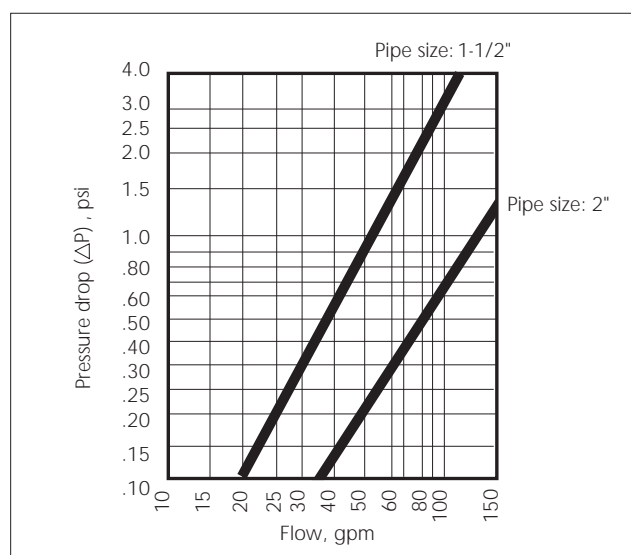

\*Based on housing only. Fluid viscosity, filter bag used, and expected dirt loading should be considered when sizing a filter.

**BAG VESSELS**

# How To Order

## Model LCO

**Dimensions (IN)**

Build an ordering code as shown in the example.

	Housing				Options			
<b>Example :</b>	LC08	30	2P	*	12	C	B	PB
<b>MODEL</b>	LC06	LC08						
<b>HOUSING SIZE</b>								
18-inch (6)	=18							
30-inch (8)	=30							
<b>PIPE SIZE</b>								
1-1/2-inch female NPT (6)	= 1-1/2P							
2-inch female NPT (8)	= 2P							
<b>OUTLET STYLE</b>								
Side/Bottom Unistyle	= *							
<b>PRESSURE RATING</b>								
125 psi	= 12							
<b>HOUSING MATERIAL</b>								
Carbon steel	= C							
304 Stainless steel	= S							
<b>COVER SEAL</b>								
Buna N	= B							
Ethylene propylene	= E							
Viton® Fluoroelastomer	= V							
<b>BASKET TYPE</b>								
Filter bag basket	= PB							

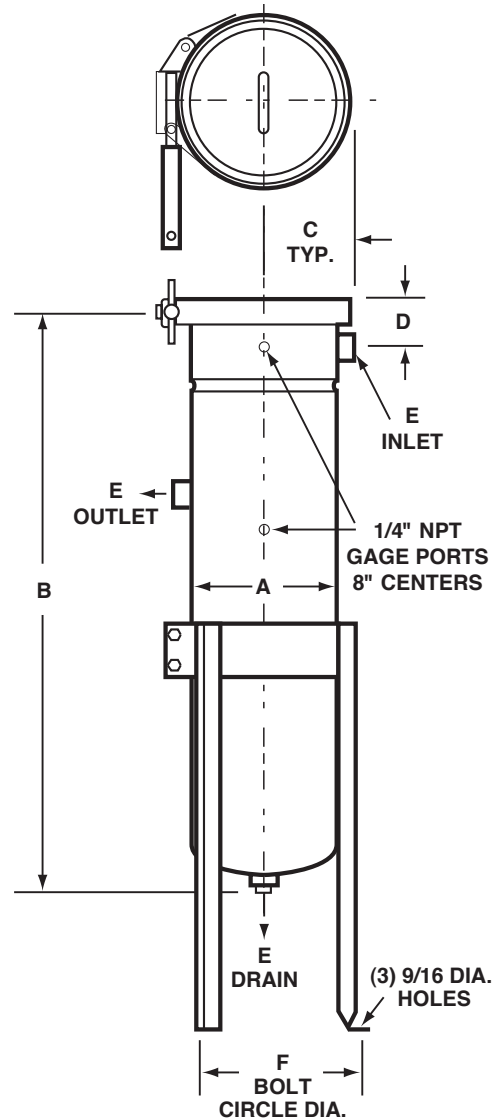

MODEL NUMBER & Dim. A	B	C	D	E	F	PSI	Weight, lb (Approx)
6 (6.0)	28.0	4.3	3.0	1.5	9.5	125	50
8 (8.6)	35.9	6.0	3.5	2.0	12.0	125	70

Dimensions are reference only and should not be used for hard plumbing. Consult factory for certified drawings.

# Model 82 Dual Capacity Bag Filter And Basket Strainer

**Extra capacity at higher flow rates!**

Matrix dual capacity housings can serve as either basket strainers or bag filters. Covers are easily removed, without tools, and the basket or bag is quickly and easily cleaned or replaced. Matrix's bag-sized pleated cartridges will provide even greater dirt-holding capacity.

**Low price, greater dirt holding capacity, and higher flow rates make the Model 82 a very cost-efficient choice!**

## BENEFITS AND OPTIONS

### BENEFITS

- Low pressure drops
- Permanently-piped housings
- Covers are O-ring sealed
- Carbon steel or stainless steel (304 or 316) housings
- Housings are electropolished to resist adhesion of dirt or scale
- Adjustable-height legs
- For flow rates to 440 gpm
- ASME code stamp available
- Large-area, heavy-duty baskets
- Dual stage straining/filtering

### OPTIONS

- Higher pressure ratings
- Extra-length legs
- Heat jacketing
- Liquid displacers for easier servicing



## **BASKET DATA** (each basket, two baskets total)

Depth inches (nominal)	Diameter (inches)	Surface Area (sq. ft.)	Volume (cu. in.)	Bag Size No.
15	6.7	2.3	500	1
30	6.7	4.4	1000	2

# BAG VESSELS

## How To Order

Build an ordering code as shown in the example

## Dimensions (IN)

	Housing				Options							
	82	30	4F	1	15	C	B	S	BM	200	D	C
<b>Example:</b>												
MODEL 82 = 82												
<b>HOUSING SIZE</b>												
15 inch = 15												
30 inch = 30												
<b>PIPE SIZE, NPT &amp; FLANGED</b>												
2-in. 150 or 300-lb ANSI flange* = 2F												
3-in. 150 or 300-lb ANSI flange* = 3F												
4-in. 150 or 300-lb ANSI flange* = 4F												
6-in. 150 or 300-lb ANSI flange* = 6F												
*Dependent on required pressure rating												
<b>OUTLET STYLE</b>												
Side = 1												
<b>PRESSURE RATING<sup>1</sup></b>												
150 psi (flanged) = 15												
300 psi (flanged) = 30												
<b>HOUSING MATERIAL</b>												
Carbon steel = C												
304 stainless steel = S												
316 stainless steel = S6												
<b>COVER SEAL</b>												
Buna N = B												
Ethylene Propylene = E												
Viton® Fluoroelastomer = V												
Teflon® Encapsulated Viton® = TV												
Teflon® (solid white) (6 Bolt Cover) = TW												
<b>BASKET SEAL</b>												
Seal (required) = S												
<b>BASKET TYPE</b>												
Filter bag basket <sup>2</sup> = PB												
Strainer basket = P												
Filter bag basket, mesh lined <sup>2</sup> = BM												
Strainer basket, mesh lined = M												
Filter bag basket, heavy wire mesh = HWM												
<b>BASKET, MEDIA SIZE</b> , no symbol if type B basket was selected												
Type P perforation diameters 1/4, 3/16, 9/64, 3/32, 1/16												
Type M and BM mesh sizes 20, 30, 40, 50, 60, 70, 80, 100, 150, 200 = 200												
<b>DISPLACER</b>												
Displacer = D												
<b>ASME CODE STAMP</b>												
Code = C												

- Higher pressures are available, consult factory.
- Flanges provided with the housing match the pressure rating of the vessel. Housings rated 150 psi have 150 class flanges. Housings rated 300 psi have 300 class flanges.

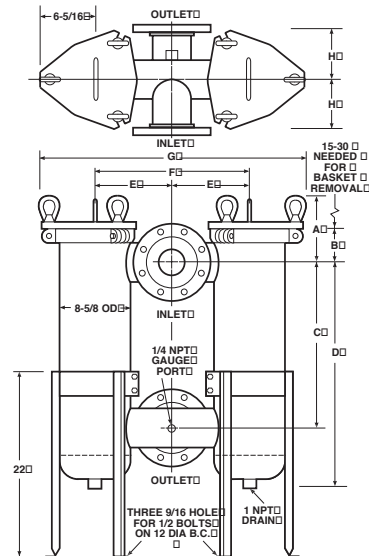

Pipe Size	2	3	4	6
<b>A</b>	6-5/8	7-1/2	7-1/2	9
<b>B</b>	2-7/8	3-3/4	3-3/4	5-1/4
<b>C (15 in)</b>	14-1/2	14-1/2	14-1/2	14-1/2
<b>(30 in)</b>	29-1/2	29-1/2	29-1/2	29-1/2
<b>D (15 in)</b>	21-3/16	22-3/32	22-3/32	23-9/16
<b>(30 in)</b>	36-3/16	37-3/32	37-3/32	38-9/16
<b>E</b>	8	8	9	9
<b>F</b>	16	16	18	18
<b>G</b>	28-9/16	28-9/16	30-9/16	30-9/16
<b>H</b>	4-1/2	5-1/2	6-1/2	8

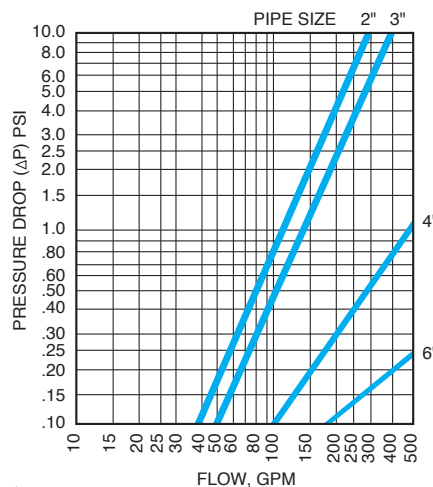

\*Based on housing only. Fluid viscosity, filter bag used, and expected dirt loading should be considered when sizing a filter.

Dimensions are reference only and should not be used for hard plumbing. Consult factory for certified drawings.

# The All Plastic PVDF/Polypro Model 8 Bag Filter Housing

**Excellent for use in pure, ultra-pure, and corrosive applications**

Matrix's Generation II filter housings incorporate a unique one piece, seamless body that handles flows to 100 gpm. It is rated to 100 psi at 150°F, and offers excellent resistance to corrosion. In addition Matrix has added new features:

## BENEFITS AND OPTIONS

### **BENEFITS**

- All molded construction
- 2-inch flat face flange connections
- Unistyle piping configuration (side and/or bottom outlet)
- Accepts all number 2 sized bags or 500 Series Cartridges (down to 0.5µ absolute)
- Wide selection of cover o-ring materials
- External cover and pressure threads with plug
- Hold down assembly



### **OPTIONS**

- Cover vent and drain valve
- Duplex and multiplex arrangements available
- Leg assembly (stainless steel)
- Pressure differential instrumentation
- Also available in PVDF

## DESIGN DETAILS

An easy to remove cover and basket make bag change-out quick, clean and simple. No special tools are needed, and the filter is back in service in a matter of minutes. The cover threads are external, and have no contact with the process fluids to prevent product accumulation. For extra strength the cover features buttress-style threads. The housing is complete with a cover vent, drain and gage port connections. The gauge connections allow for the use of Matrix differential pressure indicating equipment that assist in determining bag change-out. This can be accomplished by utilizing our pressure gauges, switches options. It's versatile unistyle design, side or bottom outlet, makes piping easy in any arrangement.



Plastic model base shown above.

## CONSTRUCTION

This durable, corrosion resistant design is constructed from special polymer compounds. The Polypro housing is molded of reinforced chemically coupled polypropylene homopolymer. The addition of a UV stabilizer makes it suitable for outdoor use.



# BAG VESSELS

## How To Order

Build an ordering code as shown in the example

Matrix's Generation II Polypro housings are designed to accept all number 2 size elements, including our standard bags, and bag-sized pleated cartridges,.

	Housing				Option
<b>Example:</b>	<b>CR8</b>	<b>30</b>	<b>2F</b>	<b>*</b>	<b>10 P B</b>
<b>MODEL NO.</b> Corrosive Resistant Model 8 = <b>CR8</b>					
<b>HOUSING SIZE</b> 30 inch = <b>30</b>					
<b>PIPE SIZE (Flange)</b> 2-inch Flat Face Class 150 = <b>2F</b>					
<b>OUTLET STYLE</b> Side/Bottom Unistyle = <b>*</b>					
<b>PRESSURE RATING</b> 100 psi = <b>10</b>					
<b>HOUSING MATERIAL</b> Polypropylene = <b>P</b> PVDF = <b>K</b>					
<b>COVER SEAL</b> Buna N = <b>B</b> Ethylene Propylene = <b>E</b> Viton = <b>V</b> Teflon Encapsulated Viton = <b>TV</b>					

## Technical Specifications

<b>Element Size:</b>	No. 2 Size Elements
<b>Piping Connections:</b>	2" ANSI B16.5 FF Flange
<b>Housing Material :</b>	Glass-reinforced polypropylene with UV stabilizer or PVDF
<b>Basket Material:</b>	Natural polypropylene or PVDF
<b>Recommended Change Out:</b>	15 PSID
<b>Pressure Rating:</b>	100 psi @ 150°F
<b>Shipping Weight:</b>	50lb (approx.)

## Dimensions (IN)

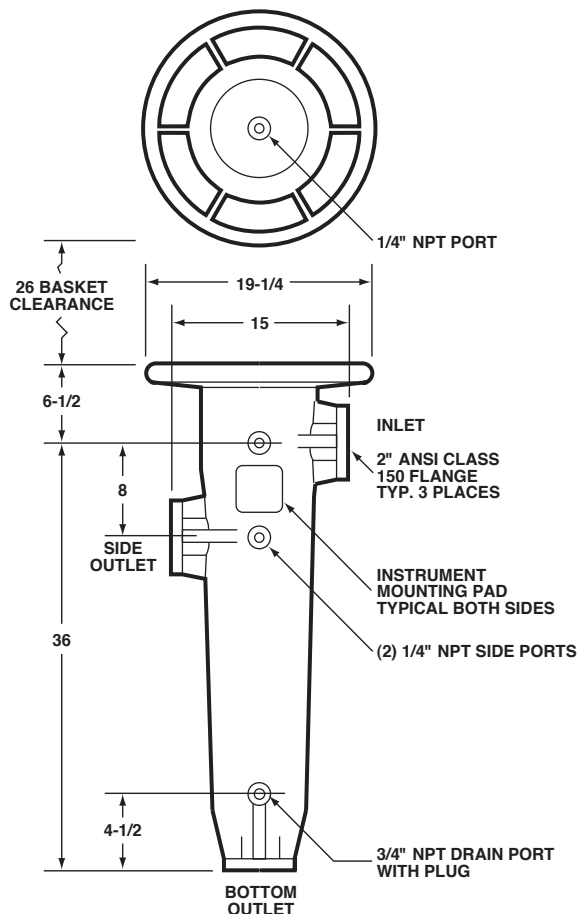

Dimensions are reference only and should not be used for hard plumbing. Consult factory for certified drawings.

## Temperature vs. Pressure

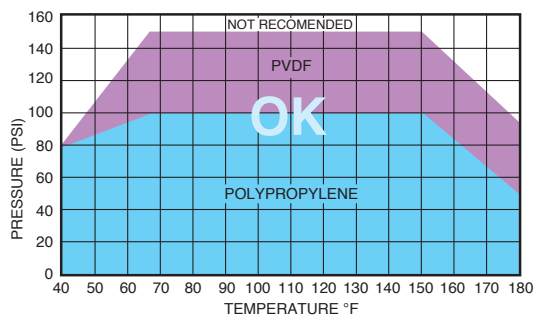

NOTE: Not for use in conditions under 40°



# Multi-Bag Filter Standard Features

## BAG VESSELS

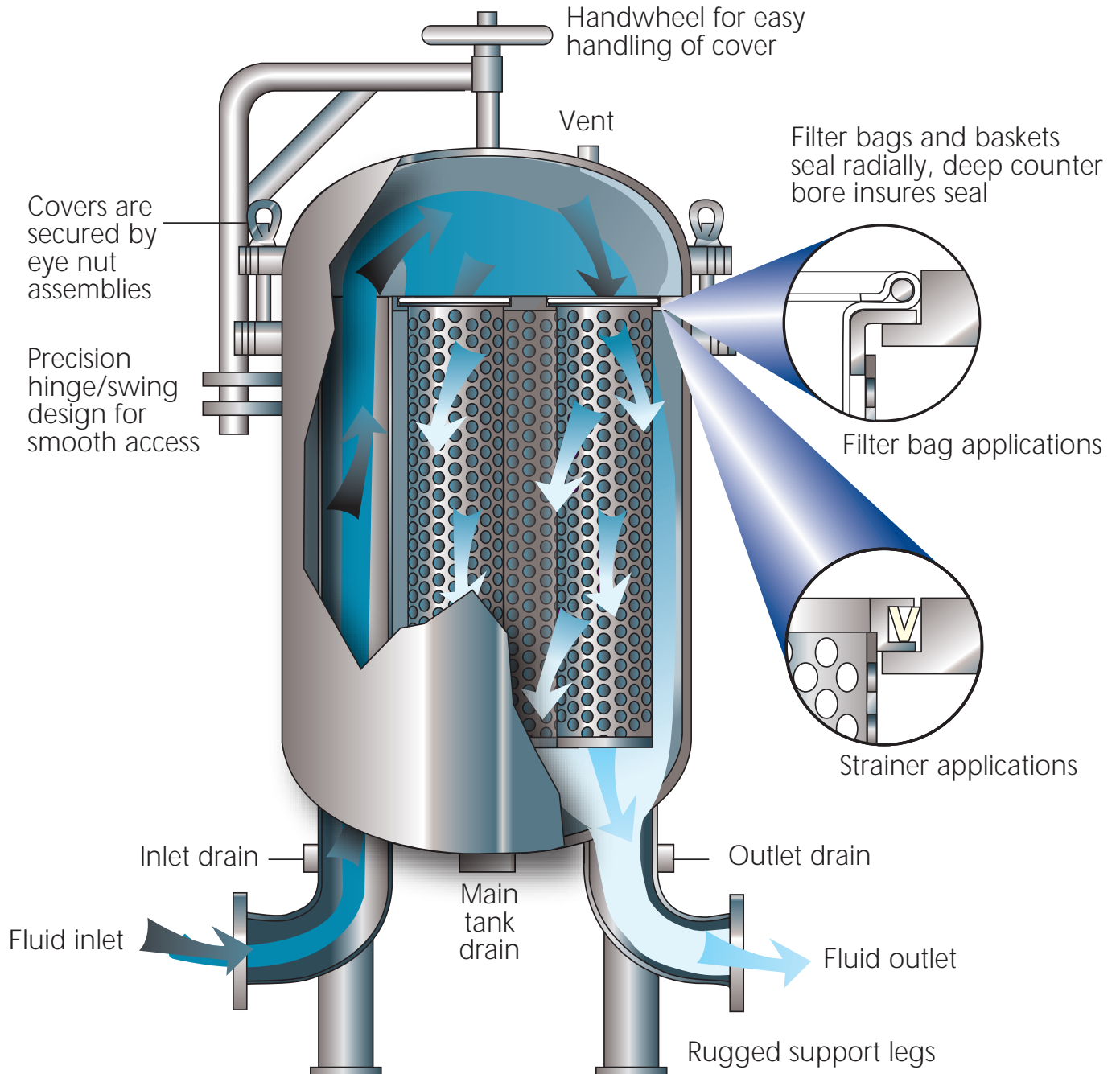

### Typical Multi-basket Strainer and Multi-bag Filter Housing

Unfiltered fluid enters the bottom of the housing and flows into the open area under the dome of the cover. Flow is distributed uniformly through the bags or baskets, where they can be removed easily and completely.



## BAG VESSELS

# Multi-Basket Strainers and Multi-Bag Filters

These multi-basket strainers and bag filters offer a wide range of flow capacities and contaminant-holding capabilities. They contain from 2 to 23 baskets.

To serve as a strainer, a unit is ordered with perforated stainless steel baskets (mesh-lined if desired). When ordered as a filter, it's fitted with perforated stainless steel baskets designed to hold disposable or cleanable filter bags. Industry-standard size bags are used: the standard 30 inch baskets accept bag size 2, the optional 15 inch baskets take size 1.

The standard pressure rating for all models is 150 psi. All housings can be supplied with an ASME code stamp, if required.



## BENEFITS AND OPTIONS

### BENEFITS

- NSF 61 listed
- Multiple housing styles available (standard, quick access, low profile, hinged)
- Permanently piped housings are opened without tools and without disturbing the piping
- Machined cover gasket groove provides positive O-ring sealing
- Carbon steel, 304 or 316 stainless steel construction housings
- Large-area, 30 inch deep, heavy-duty, 9/64 inch perforated baskets
- Easy to clean
- Low pressure drop
- Four cover seal materials: Buna N, Ethylene Propylene, Viton®, and Teflon®
- Pressure rating 150 psi
- Flanged connections for 2 through 12 inch pipe
- Vent, drain and gage connections



### OPTIONS

- ASME code stamp
- Higher pressure ratings
- Corrosion allowances
- Steam jackets
- Special connection locations
- Bag hold down assembly (standard on QII design)
- Inner baskets for dual-stage straining or filtering
- Cleanable wire mesh lined or perforated strainer baskets
- Special alloy materials
- Hydraulic cover lifting assembly
- Sanitary fittings
- Differential pressure indicators

## DUPLEX SYSTEMS

All multi-basket models described here are also available as duplex systems. Two units come piped together with valves to permit continuous use of either unit while servicing the other. One lever actuates all valves simultaneously or it can be ordered for automatic service.



## Choose Baskets That Strain or Filter

### Whatever your needs dictate

Strainer baskets are cleanable, reusable.

A seal is supplied on any strainer basket. It forms a seal between basket and housing to prevent dirty fluid bypass. Choose between various perforation sizes or wire mesh. Strainer baskets have flat, non-perforated bottoms and contain heavy-duty handles.

Filter bag baskets hold disposable filter bags.

Filter bags have an interference fit between the bags top rim and the housing causing a positive seal to prevent fluid bypass. Filter bag baskets have flat perforated bottoms.

Filter bags are available in a wide variety of felt, micro-fiber, monofilament and multifilament mesh materials.

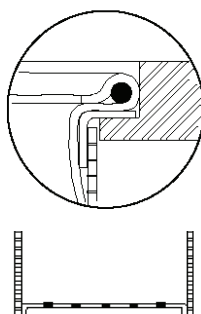
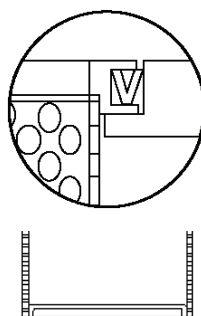

**DUAL-STAGE**- Dual-stage action will increase strainer or filter life and reduce servicing needs. This straining/filtering action can be achieved by ordering a second, inner basket. It is supported on the top flange of the outer basket. Both baskets can be utilized as strainers (with or without wire mesh linings), filter bag baskets, or a combination of strainer and bag basket.



### BASKET DATA

Surface area of each 30 in. basket: 4.4 sq. ft.

Volume of each 30 in. basket: 0.6 cu. ft.

### BASKET CONSTRUCTION

For cleanable strainer baskets, choose from the following perforation diameters: 1/4, 3/16, 9/64, 3/32, or 1/16 inch (for other not shown consult factory).

Any perforated basket can also be ordered lined with wire mesh. Stainless steel wire is used in mesh sizes 20, 30, 40, 50, 60, 70, 80, 100, 150, or 200.

Filter bag baskets, have standard 9/64 inch diameter perforations that are 51% open area. A wire mesh can also be utilized with bag baskets for two advantages:

1. Fiber migration is minimized.
2. In the unlikely event of bag rupture, the wire mesh better contains the contaminant.

## BAG VESSELS

## Choose Housing Style

### Designed to suit your requirements

The versatility of Matrix Products provides a choice of several different designs.

- Quick Access Cover (QII) features a unique counter weight design that makes opening, closing, and change-out, fast, easy, and simple. This will significantly reduce change-out time and lower operating costs. The QAC is rated to 150 PSI and constructed to meet ASME code requirements. Built-in safety features ensure that the cover cannot be opened unless the internal pressure is first released. The QII is offered with our low profile design making bags more accessible and easy to remove.
- Low Profile Design (SLP) Housings are compact and space saving, allowing for ease of bag change-out. Standard operating height is reduced, resulting in a safe design by eliminating platforms and ladders. The SLP is manufactured in any housing version, including our standard davit arm cover, QAC design, and spring assisted hinged cover.
- Standard Housing Design (STD) is durable and economic. It includes a davit arm and handwheel to facilitate cover removal. It is our most versatile housing design offering a variety of options, including our low profile design.



QII Quick Access Cover



Low Profile Design



Standard Davit Arm



# BAG VESSELS

MODEL NUMBER & Dim. A	Pipe Sizes B	Leg Bolt Circle Dia.	Standard					Weight, lb (Approx)	Low Profile				
			C	D	E	F	G		H	I	J	K	L
16	2	14.0	10.9	40.1	57.1	4.50	10.5	400	37.9	54.9	8.00	15.0	13.0
	3		42.5	59.5	5.25	12.3	425	38.3	55.3	9.00	17.0	14.0	
	4		44.9	61.9	6.00	14.0	450	N/A	N/A	N/A	N/A	N/A	
18	2	16.0	11.9	40.5	58.0	4.50	11.1	450	39.6	58.5	8.00	15.0	14.0
	3		42.9	60.4	5.25	12.9	475	40.0	58.9	9.00	17.0	15.0	
	4		45.3	62.8	6.00	14.6	500	N/A	N/A	N/A	N/A	N/A	
22	2	20.0	14.0	41.4	60.0	4.50	11.9	485	39.5	58.0	8.00	15.0	16.0
	3		43.9	62.4	5.25	13.7	500	40.0	58.5	9.00	17.0	17.0	
	4		46.2	64.7	6.00	15.4	515	39.5	58.0	9.00	19.0	18.0	
	6		50.4	69.0	7.00	18.9	560	N/A	N/A	N/A	N/A	N/A	
24	2	22.0	15.0	41.7	60.7	4.50	13.1	675	41.2	61.6	8.00	15.0	17.0
	3		44.1	63.1	5.25	14.8	700	41.6	62.0	9.00	17.0	18.0	
	4		46.5	65.5	6.00	16.6	725	41.1	61.5	9.00	19.0	19.0	
	6		50.7	69.7	7.00	20.1	750	N/A	N/A	N/A	N/A	N/A	
30	2	28.0	18.0	42.8	63.3	4.50	15.2	635	41.3	61.9	8.00	15.0	20.5
	3		45.2	65.7	5.25	17.0	650	41.8	62.4	9.00	17.0	21.0	
	4		47.6	68.1	6.00	18.7	665	41.3	61.9	9.00	19.0	22.5	
	6		51.9	72.4	7.00	22.2	705	41.2	61.8	10.0	17.0	23.0	
	8		56.4	76.8	8.25	25.7	850	N/A	N/A	N/A	N/A	N/A	
36	3	34.0	21.0	46.4	68.4	5.25	18.8	840	43.3	64.5	9.00	17.0	24.0
	4		48.8	70.8	6.00	20.6	860	43.2	64.5	9.50	19.0	25.0	
	6		53.1	75.1	7.00	24.1	870	43.2	64.4	10.5	17.0	26.0	
	8		57.6	79.6	8.25	27.6	1010	43.2	64.4	11.5	17.0	27.0	
	10		62.1	84.1	9.50	30.6	1150	N/A	N/A	N/A	N/A	N/A	
42	4	40.0	24.0	50.0	73.5	6.00	22.6	1840	45.9	70.7	9.50	19.0	28.0
	6		54.3	77.8	7.00	26.1	1870	45.9	70.6	10.5	17.0	28.0	
	8		58.8	82.3	8.25	29.6	1960	45.9	70.6	11.5	17.0	29.5	
	10		63.3	86.8	9.50	32.6	2070	45.8	70.5	12.5	17.0	30.0	
	12		68.0	91.5	11.0	36.1	2200	N/A	N/A	N/A	N/A	N/A	
48	4	46.0	27.0	51.0	76.0	6.00	24.8	2015	46.5	71.5	9.50	19.0	32.0
	6		55.4	80.4	7.00	28.3	2075	46.4	71.4	10.5	17.0	32.0	
	8		60.0	85.0	8.25	31.8	2200	46.4	71.4	11.5	17.0	32.5	
	10		64.4	89.4	9.50	34.8	2350	46.4	71.4	12.5	17.0	33.0	
	12		69.2	94.2	11.0	38.3	2530	N/A	N/A	N/A	N/A	N/A	

## Dimensions (IN) (30-inch deep basket)

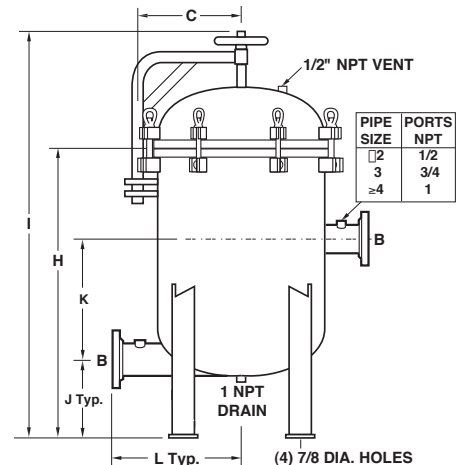
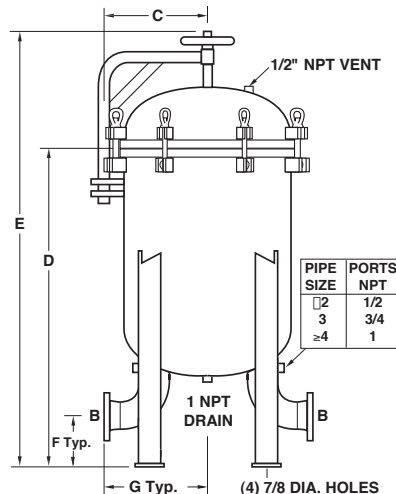
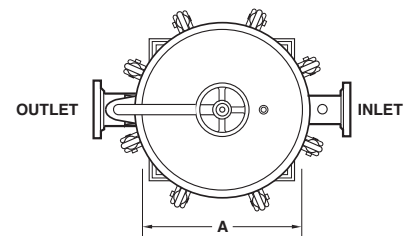
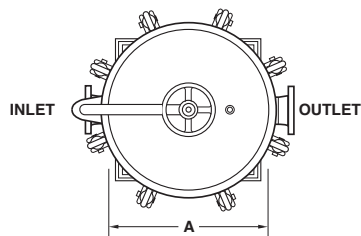

Dimensions are reference only and should not be used for hard plumbing. Consult factory for certified drawings.

Standard

Low Profile

# BAG VESSELS

		QII Low Profile								
MODEL NUMBER & Dim. A	Leg Bolt Circle Dia.	Pipe Size	A	B	C	D	E	F	G	H
16 & 18	16.0	18.0	2	40.0	53.2	8.00	15.0	14.0	35.5	
			3	40.4	53.6	9.00	17.0	15.0		
22	22.0	24.0	2	41.5	56.2	8.00	15.0	16.0	35.5	
			3	41.9	56.6	9.00	17.0	17.0		
			4	41.4	56.1	9.00	19.0	18.0		
24	22.0	24.0	2	41.5	56.2	8.00	15.0	17.0	38.5	
			3	41.9	56.6	9.00	17.0	18.0		
			4	41.4	56.1	9.00	19.0	19.0		
30	28.0	30.0	2	43.0	59.2	8.00	15.0	20.5	41.5	
			3	43.4	59.6	9.00	17.0	21.0		
			4	42.9	59.1	9.00	19.0	22.5		
			6	42.9	59.1	10.00	17.0	23.0		
36	34.0	36.0	3	44.9	62.6	9.00	17.0	24.0	44.5	
			4	44.9	62.6	9.50	19.0	25.0		
			6	44.9	62.6	10.5	17.0	29.5		
			8	44.9	62.6	11.5	17.0	27.0		
42	40.0	42.0	4	46.4	65.6	9.5	19.0	28.0	47.5	
			6	46.4	65.6	10.5	17.0	28.0		
			8	46.4	65.6	11.5	17.0	29.5		
			10	46.3	65.5	12.5	17.0	30.0		
48	46.0	48.0	4	47.9	68.6	9.5	19.0	32.0	50.5	
			6	47.9	68.6	10.5	17.0	32.0		
			8	47.9	68.6	11.5	17.0	32.5		
			10	47.8	68.5	12.5	17.0	33.0		

## Model Selection (For all housings)

Model No.	Number of Baskets	Straining, Filtering Area, ft <sup>2</sup>	Nominal Flow Rate (gpm)**	Inlet/Outlet Size (in)
16	2	8.8	200	2,3,4*
18	3	13.2	300	2,3,4*
22	4	17.6	400	2,3,4,6*
24	6	26.4	600	2,3,4,6*
30	8	35.2	800	2,3,4,6,8*
36	12	52.8	1200	2,3,4,6,8,10*
42	17	74.8	1700	2,3,4,6,8,10,12*
48	23	101.2	2300	2,3,4,6,8,10,12*

\* Not available on SLP, HLP, and QII styles.

\*\* Nominal flow rate is based on water @ 1 psi ΔP. For optimum filtering effectiveness, a maximum fluid velocity of 10 ft/sec should be maintained.

## Dimensions (IN)

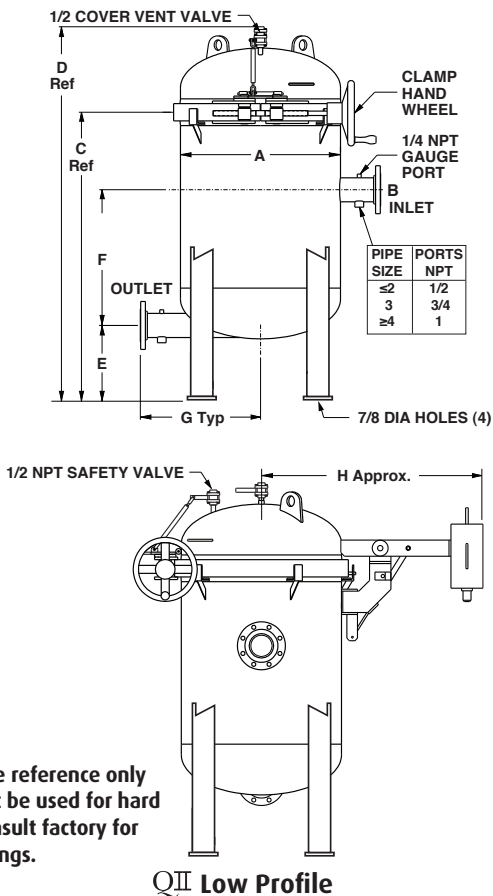

Dimensions are reference only and should not be used for hard plumbing. Consult factory for certified drawings.

QII Low Profile

## PRESSURE DROP DATA

Basket strainers and bag filters are usually selected so that the pressure drop does not exceed 2 psi, when they are clean. Higher pressure drops may be tolerated when contaminant loading is low.

### Determining housing pressure drop:

The pressure drops shown on the graph are reliable for all multi-basket housings, including strainer baskets or bag filter (perforated only or mesh lined). The pressure drop of any housing is governed by the size of the inlet and outlet, not the vessel itself.

- Using the desired pipe size and approximate flow rate, determine the basic pressure drop from the graph.
- Multiply the pressure drop obtained in step 1 by the viscosity correction factor found in the accompanying table.
- You now have the pressure drop for a clean multi-basket unit. If bag filters are employed, you must add the pressure drop they incur to get a true pressure drop for the assembly.

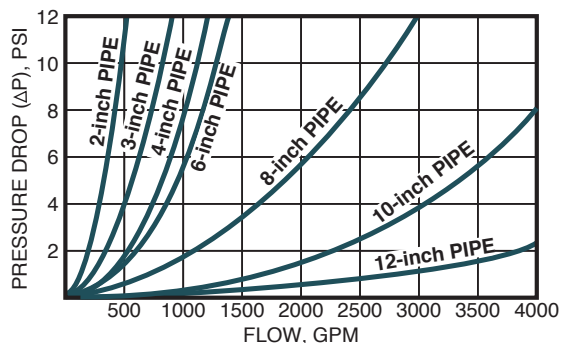

Recommended flow rates are based on housing only. Fluid viscosity, filter bag used, and expected dirt load should be considered when sizing a filter.

## Viscosity Factors

		CPS NUMBER							
(H <sub>2</sub> O)		50	100	200	400	600	800	1000	2000
.65		.85	1.00	1.10	1.20	1.40	1.50	1.60	1.80



# How To Order

Build an ordering code as shown in the example

**Example:** **SLP 24 30 4F 1 15 C B S M 20 C 2P 1/16**

	Housings			Options							OPTIONAL INNER BASKET			
	SLP	24	30	4F	1	15	C	B	S	M	20	C	2P	1/16

**HOUSING STYLE**  
 Standard (std) = No Symbol  
 Standard Low Profile = SLP  
 Quick Access Cover = Q

**MODEL NO.**  
 16 = 16      30 = 30  
 18 = 18      36 = 36  
 22 = 22      42 = 42  
 24 = 24      48 = 48

**BASKET DEPTH**  
 15-in. = 15  
 30-in. (std) = 30

**PIPE SIZE (FLANGED<sup>1</sup>)**  
 2-in. (Std, SLP, HLP 16-48 / QII 18 & 24) = 2F  
 3-in. (Std, SLP, HLP 16-48 / QII 18 & 24) = 3F  
 4-in. (Std 16-48 / SLP, HLP 22-48 / QII 24) = 4F  
 6-in. (Std 22-48 / SLP, HLP 30-48) = 6F  
 8-in. (Std 30-48 / SLP, HLP 36-48) = 8F  
 10-in. (Std 36-48 / SLP, HLP 42 & 48) = 10F  
 12-in. (Std 42, 48) = 12F

**OUTLET STYLE**  
 In-line, bottom (std) = 1  
 Side inlet/outlet (SLP, HLP, QII) = 2  
 Side inlet/outlet, same side (SLP, HLP, QII) = 4

**PRESSURE RATING<sup>2</sup>**  
 150 psi (flanged) = 15

**HOUSING MATERIAL**  
 Carbon steel = C  
 304 stainless steel = S  
 316 stainless steel = S6

**COVER SEAL**  
 Buna N (N/A on Q housing) = B  
 Ethylene Propylene (N/A on Q housing) = E  
 Viton® = V  
 Teflon® Encapsulated Viton® (N/A on Q housing) = TV  
 Teflon® (solid white) (N/A on Q housing) = TW

**BASKET SEAL**  
 No seal = N  
 Seal (only on strainer housings) = S

**OPTIONAL INNER BASKET, MEDIA SIZE**  
 Perforation diameters (for type 2P baskets)  
 1/4, 3/16, 9/64, 3/32, 1/16  
 Mesh sizes (for type 2M & 2BM baskets)  
 20, 30, 40, 50, 60, 70, 80, 100, 150, or 200

**OPTIONAL INNER BASKET, TYPE**  
 2B = Filter bag basket, 9/64 perforations  
 2P = Strainer basket, perforated metal  
 2BM = Filter basket, mesh lined  
 2M = Strainer basket, perforated, mesh lined

**ASME CODE STAMP**  
 C = Code  
 NSF = NSF 61 listed

**BASKET, MEDIA SIZE No symbol if type B basket was selected**  
 Perforation diameters (for type P baskets)  
 1/4, 3/16, 9/64, 3/32, 1/16  
 Mesh sizes (for type M & BM baskets)  
 20, 30, 40, 50, 60, 70, 80, 100, 150, or 200

**BASKET, TYPE**  
 PB = Filter bag basket, 9/64 perforations  
 P = Strainer basket, perforated metal  
 BM = Filter bag basket, perforated, mesh lined  
 M = Strainer basket, perforated, mesh lined  
 HWM = Filter bag basket, heavy wire mesh

1. Flanges provided with the housing match the pressure rating of the vessel. Housings rated 150 psi have 150 class flanges. Housings rated 300 psi have 300 class flanges. Other styles and classes available. ANSI B16.5 Pressure-Temperature rating tables determine flange class for ASME code housings. Consult factory.

2. Higher pressure ratings available. Consult factory.

\*Note: Because of its unique Quick Access Cover, the Q (QII) housing style is available only with a Viton cover seal.



Application Notes

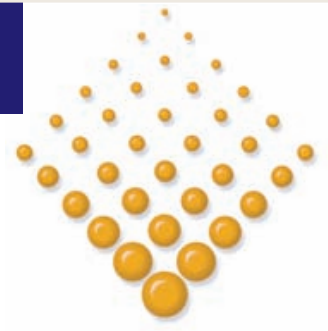

**MATRIX**  
SEPARATIONS



# Multi-Basket Strainers and Multi-Bag Filters with Spring-Access Cover

These multi-basket strainers and bag filters offer a wide range of flow capacities and contaminant-holding capabilities. They contain from 2 to 23 baskets/bags. Larger units that hold more baskets/bags are available, consult Matrix Separations, LLC.

- Low Profile Design Housings are compact and space saving, allowing for ease of bag change-out. Standard operating height is reduced, resulting in a safe design by eliminating platforms and ladders.
- Spring Assisted Hinged Cover opens and closes without effort. Simply loosen the swing bolts and lift the cover up to open. An automatic cover stop is provided.
- The units meet ASME code requirements for 150 PSI ratings.

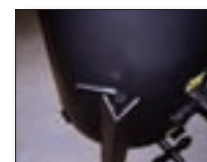
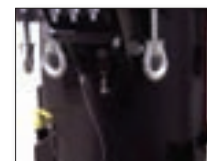
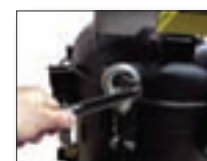

## BENEFITS AND OPTIONS

### BENEFITS

- Permanently piped housings are opened without disturbing the piping
- Machined cover seal groove provides positive sealing
- Carbon steel, 304 or 316 stainless steel construction housings (wetted parts)
- Large-area, 30-inch deep, heavy-duty, 9/64-inch perforated baskets
- Easy to clean
- Low pressure drop
- Three cover seal materials: Buna N, Ethylene Propylene, and Viton®
- Pressure rating 150 psi
- Flanged connections for 2 through 8-inch pipe
- Vent, drain and gauge connections
- Bag hold down assembly

### OPTIONS

- ASME code stamp
- Special connection locations
- Inner baskets for dual-stage straining or filtering
- Cleanable wire mesh lined or perforated strainer baskets
- Special alloy materials
- Sanitary fittings
- Bag or cartridge design
- Differential pressure indicators
- Safety pressure release
- Steam jackets (body jacket only)

**SPECIALTY VESSELS**

**Dimensions**

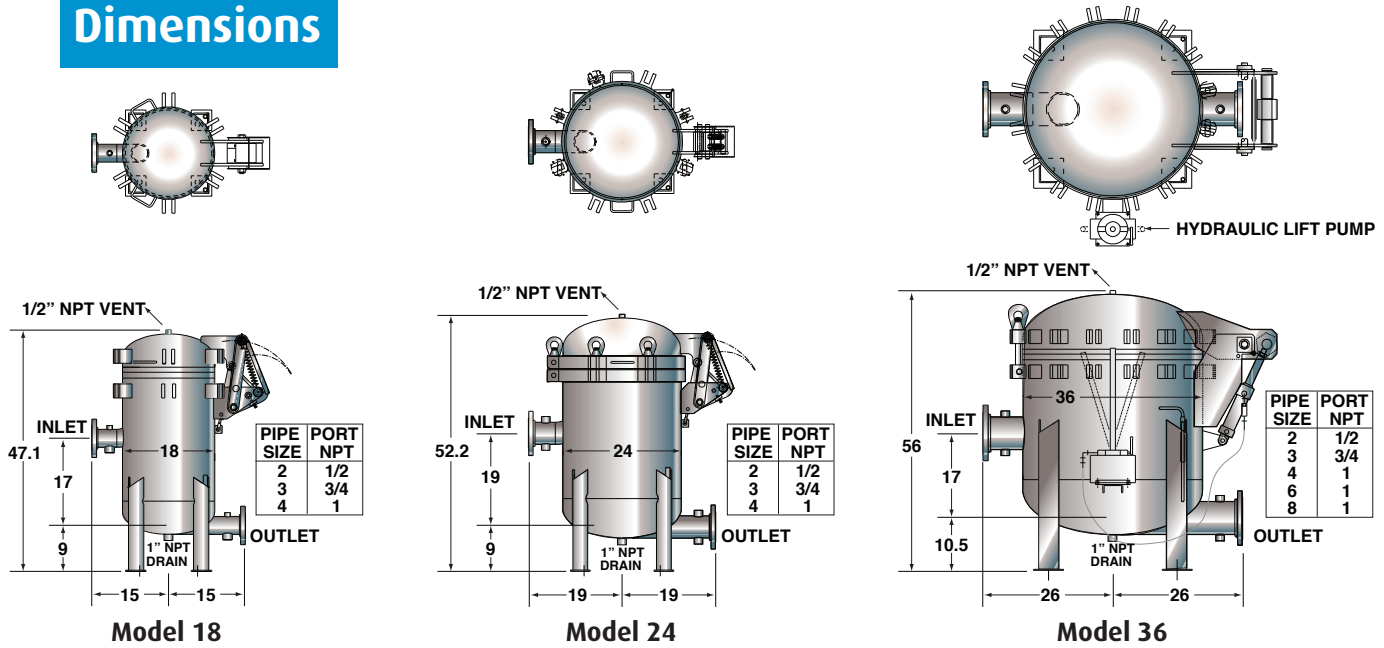

Dimensions are reference only and should not be used for hard plumbing. Consult factory for certified drawings.

**How To Order**

Build an ordering code as shown in the example

**Example:** **HLP18 30 4F 2 15 C B S M 20 C**

<b>MODEL NO.</b>	18 = HLP18 (3-Bag Unit)	24 = HLP24 (6-Bag Unit)	36 = HLP36 (12-Bag Unit)
<b>BASKET DEPTH</b>	15-in. = 15	30-in. (std) = 30	
<b>PIPE SIZE (FLANGED<sup>1</sup>)</b>	2-in. (All Models) = 2F	3-in. (All Models) = 3F	4-in. (Model 24/36) = 4F
	6-in. (Model 36) = 6F	8-in. (Model 36) = 8F	
<b>OUTLET STYLE</b>	Side inlet/outlet = 2	Side inlet/outlet (same side) = 4	
<b>PRESSURE RATING<sup>2</sup></b>	150 psi (flanged) = 150		
<b>HOUSING MATERIAL</b>	Carbon steel = C	304 stainless steel = S	316 stainless steel = S316

<b>ASME CODE STAMP</b>	C = Code	NSF = NSF 61 listed
<b>BASKET, MEDIA SIZE No symbol if type B basket was selected</b>	Perforation diameters (for type P baskets) 1/4, 3/16, 9/64, 3/32, 1/16	
	Mesh sizes (for type M & BM baskets) 20, 30, 40, 50, 60, 70, 80, 100, 150, or 200	
<b>BASKET, TYPE</b>	PB = Filter bag basket, 9/64 perforations	P = Strainer basket, perforated metal
	BM = Filter bag basket, perforated, mesh lined	M = Strainer basket, perforated, mesh lined
	HWM = Filter bag basket, heavy wire mesh	
<b>BASKET SEAL</b>	N = No seal	S = Seal (only on strainer housings)
<b>COVER SEAL</b>	B = Buna N	E = Ethylene Propylene
	V = Viton®	

1. Flanges provided with the housing match the pressure rating of the vessel.
2. Housings rated 150 psi have 150 class flanges. Other styles and classes available. ANSI B16.5 Pressure-Temperature rating tables determine flange class for ASME code housings. Consult factory.

# Duplex Bag Filters And Basket Strainers

## Trouble free, continuous operation

Duplex filters permit continuous operation, reducing overall operating costs. Flow can be switched back and forth between two filter vessels, allowing one side to be serviced while the other is in use.

The Matrix duplex, using a single multi-ported valve operating system, is a better solution, and offers many benefits:

- Four separate valves are used all operated simultaneously by a single lever.
- Valves use the standard butterfly design, known for their effective seal, low pressure drop, and low cost.
- Any of the valves can be serviced individually, without need to disturb the other valves or piping. Replacements are readily available.
- Valves are soft-seated to provide bubble-tight closure.
- A variety of valve seal materials is available for use with a number of hard-to-handle fluids.
- Pressure drop is minimized because the flow path has the equivalent of only four elbows instead of the usual six.
- Mechanical stops assure that the valves are completely open or closed.
- A single-valve pressure balancing vent system is furnished to ease movement of the lever and to fill the just serviced vessel before use.
- Vents in filter covers and drain ports in filter housing speed evacuation and filling.
- Remotely operated power actuators and automatic power actuation (triggered by pressure differential sensing) are offered. Air or electric actuation is best if such power is available.



## SPECIALTY VESSELS

### CONSTRUCTION MATERIALS

Available in carbon steel, 304 stainless steel, or 316 stainless steel.

Internal valve parts other than seals are 316 stainless steel.

Four different materials can be ordered for all seals involved.

All baskets and mesh linings are made of stainless steel. 304 stainless will be supplied with carbon and 304 housings, 316 stainless with 316 housings.

### CHOOSING A BASKET STRAINER OR BAG FILTER

Choose between straining a fluid (removing particles down to 74 micron size) and filtering it (removing particles down to 1 micron).

### PRESSURE DROP DATA

Basket strainers and bag filters are usually selected so that the pressure drop does not exceed 2 psi, when they are clean. Higher pressure drops may be tolerated, when contaminant loading is low.

The pressure drop data are accurate for all housings with strainer or filter bag baskets. When filter bags are added, total pressure drop becomes the sum of the pressure drop as determined by the steps below.

#### Follow these easy steps:

1. Using the desired pipe size and approximate flow rate, determine the basic pressure drop from the appropriate graph.

2. Multiply the pressure drop obtained in step 1 by the viscosity correction factor found in the accompanying table.

This is the adjusted (clean) pressure drop for all baskets without filter bags.



	Viscosity, cps								
	1 (H <sub>2</sub> O)	50	100	200	400	600	800	1000	2000
All unlined baskets	.65	.85	1.00	1.10	1.20	1.40	1.50	1.60	1.80
40-mesh lined	.73	.95	1.20	1.40	1.50	1.80	1.90	2.00	2.30
60-mesh lined	.77	1.00	1.30	1.60	1.70	2.10	2.20	2.30	2.80
80-mesh lined	.93	1.20	1.50	1.90	2.10	2.40	2.60	2.80	3.50
100-mesh lined	1.00	1.30	1.60	2.20	2.40	2.70	3.00	3.30	4.40
200-mesh lined	1.30	1.70	2.10	3.00	3.40	3.80	4.40	5.00	6.80



## Selecting A Size

### SPECIALTY VESSELS

These descriptions and flow charts can aid in size selection. Capacities given are for each of the two vessels in any duplex system.

#### Model 4—For flow rates to 50 gpm\*

- Pipe sizes 1, 2, or 3 inch, flanged
- Basket depth: 12 inches (nominal)

##### BASKET DATA

Depth (nominal, inches)	Diameter (inches)	Surface Area	Volume (cu. in.)
12	3.9	1.0	130

#### Model 6—For flow rates to 100 gpm\*

- Delivers 3.4 square feet of basket or bag surface without need for ASME code construction.
- Can be fitted to hold cartridge filter elements
- Pipe sizes 1, 2, 3, or 4 inches (flanged).
- Two basket depths: 18, or 30 inches (nominal)

##### BASKET DATA

Depth (nominal, inches)	Diameter (inches)	Surface Area	Volume (cu. in.)
18	5	2.0	350
30	5	3.4	630

#### Model 8—For flow rates to 220 gpm\*

- Can be fitted to hold cartridge filter elements
- Pipe sizes 2, 3, or 4 inch, flanged.
- Two basket depths: 15 or 30 inches (nominal)

##### BASKET DATA

Depth (nominal, inches)	Diameter (inches)	Surface Area	Volume (cu. in.)
15	6.7	2.3	500
30	6.7	4.4	1000

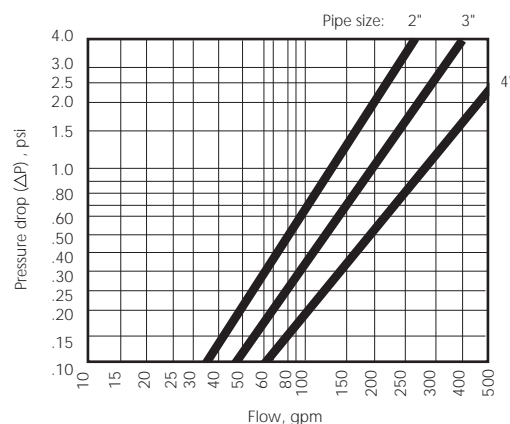
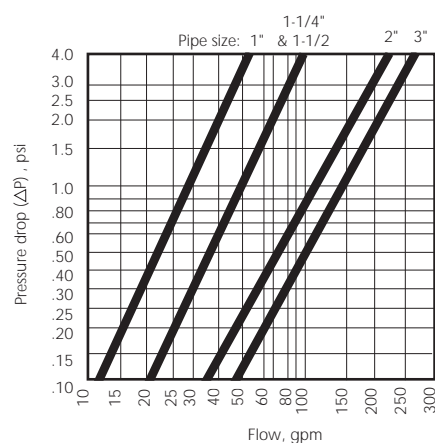
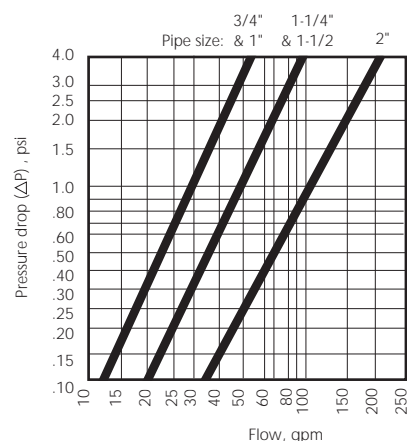

\*Based on housing only. Fluid viscosity, filter cartridge used, and expected dirt loading should be considered when sizing a filter.



## SPECIALTY VESSELS

## Single-Basket Models (IN)

Model	Flange Size	A For basket depths				B	B1 (Model 82 only)	C	D	F	G	H	I	J (Model 82 only)
		12	15	18	30									
4	1	18				29.5		9	15	14	19	22.25	7.0	
	2	18				29.5		9	15	14	19	22.25	7.0	
	3	22.125				31.75		11	17	14	19	24.25	7.0	
6	1			25.75	37.75	34.75		9	15	18	20.5	24.25	10.0	
	2			25.75	37.75	34.75		9	15	18	20.5	24.25	10.0	
	3			27.75	39.625	37		11	17	18	20.5	26.25	10.0	
	4			27.625	39.625	41.5		13	18	18	20.5	31	10.0	
8	1		23.75		38.75	44.75	45.75	9	15	22	21.3	32.25	11.6	28.6
	2		23.75		38.75	44.75	45.75	9	15	22	21.3	32.25	11.6	28.6
	3		25.625		40.625	47	48	11	17	22	21.3	34.5	11.6	30.6
	4		25.625		40.625	49.5	50.5	13	18	22	21.3	37	11.6	30.6

The inlets and outlets on all duplex systems come standard in a horizontal configuration (facing opposite directions). The option of arranging the inlet and outlet is available in three positions, 90° apart. The system is designed with flanged tees, allowing the orientation to be changed in the field.

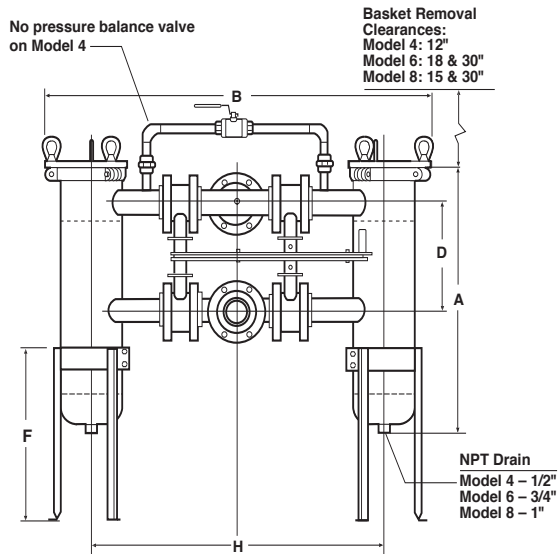
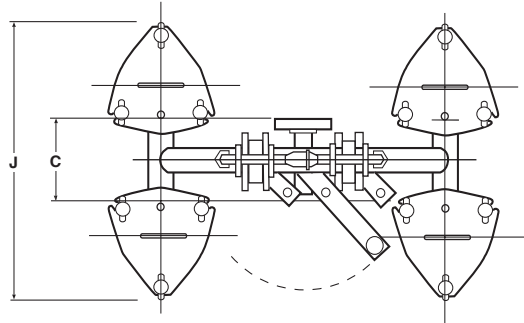
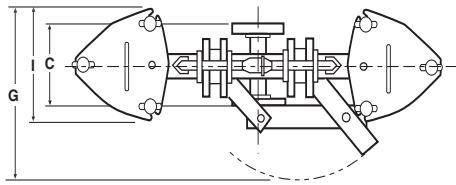

Duplex Models 4, 6, and 8

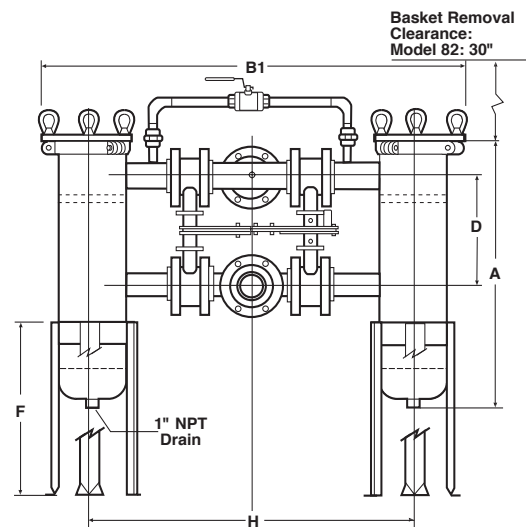

Duplex Model 82



# Duplex Bag Filters With Automatic Sequencing

**Continuous, uninterrupted filtering of large flows of liquid is provided by these automatic duplex filters**

When the filter bags on one side get to the point of requiring change-out, the incoming flow is automatically diverted to the clean filter bags on the other side. Maintenance personnel are alerted to the need to change the dirty filters so that the system will be ready for the next cycle.

## TYPICAL STEP-BY-STEP OPERATION

1. As the filter bags in vessel A become so loaded with particulate that the differential pressure increases to a selected level, a switch actuates an air-operated valve in the loop pipe. This diverts a small flow of fluid to fill vessel B. After enough time to equalize the pressure in the two vessels, the four main valves are actuated by an air cylinder.
2. The duplex valve system shifts four valves at once, closing the inlet and outlet on vessel A and opening the two on vessel B.

An indicator light (and remote signal, if desired) shows that vessel B is now being utilized. Another light shows that the shift from one vessel to the other has occurred, and that filter bags need to be replaced. An electrical interlock prevents another shift cycle until the dirty filter bags have been replaced and the operator has pushed a reset button.

3. With the interlock released, the system is ready to cycle whenever the pressure differential again indicates the necessity.

## AVAILABILITY

The automatic duplex valve system can be ordered on any Maxtrix filter vessel. The standard multi-bag filter models are shown in the table.

The main inlet and outlet connections can be positioned to accommodate any flow direction within reason.

Systems are shipped assembled, ready for use, often on dollies or skids to assist putting them in place.

Matrix Model No.*	Number of bags	Nominal flow rate, gpm
16	2	400
18	3	600
22	4	800
24	6	1200
30	8	1600
36	12	2000
42	17	3500
48	23	4500

\* Model number also indicates vessel diameter in inches.





## SPECIALTY VESSELS

## Models 16 through 48 – For flow rates to 4600 gpm

- Contain from 2 to 23 baskets
- Pipe sizes 2 through 12 inches, flanged
- Two basket depths: 15 or 30 inches (nominal) both 6.7 inches in diameter

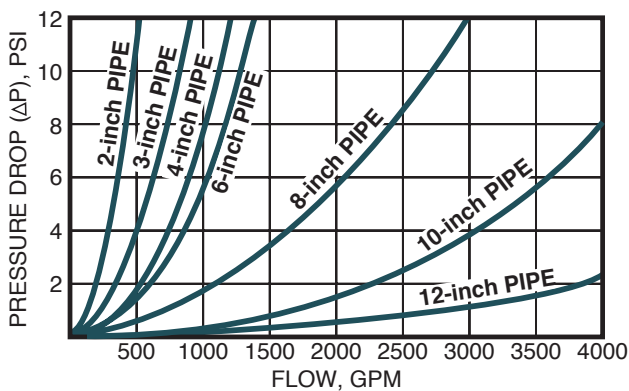

### Multi-Basket Models (IN)

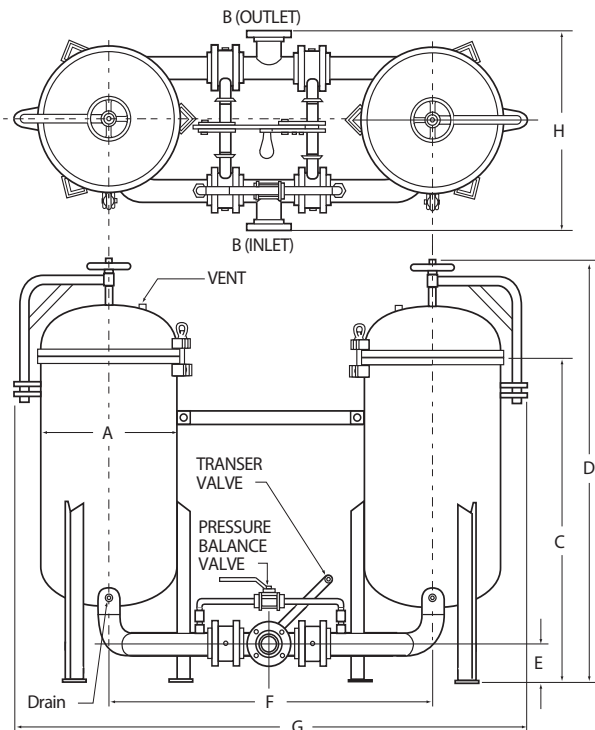

The inlets and outlets on all duplex systems come standard in a horizontal configuration (facing opposite directions). The option of arranging the inlet and outlet is available in three positions, 90° apart. The system is designed with flanged tees, allowing the orientation to be changed in the field.

Model Number	Number of Baskets	Basket Depth (nom.)	Surface Area (sq. ft.)	Flow Rate* (gpm)
16	2	30	8.8	400
18	3	30	13.2	600
22	4	30	17.6	800
24	6	30	26.4	1200
30	8	30	35.2	1600
36	12	30	52.8	2400
42	17	30	74.8	3400
48	23	30	101.2	4600

\*Based on housing only. Fluid viscosity, filter cartridge used, and expected dirt loading should be considered when sizing a filter.

Model (Dia.)	Inlet/Outlet	A	B	C	D	E	F	G	H
16	2	40.1	57.1	4.5	40.3	65.3	25.3		
	3	42.5	59.5	5.3	42.5	67.5	30.3		
	4	44.9	61.9	6.0	45.0	70.0	35.0		
18	2	40.5	58.0	4.5	42.3	69.3	26.4		
	3	42.9	60.4	5.3	44.5	71.5	31.4		
	4	45.3	62.8	6.0	47.0	74.0	36.3		
22	2	41.4	60.0	4.5	46.3	77.3	24.9		
	3	43.9	62.4	5.3	48.5	79.5	28.4		
	4	46.2	64.7	6.0	51.0	82.0	31.8		
	6	50.4	69.0	7.0	54.3	85.3	37.8		
24	2	41.7	60.7	4.5	50.3	83.3	24.1		
	3	44.1	63.1	5.3	52.5	85.5	28.8		
	4	46.5	65.5	6.0	55.0	88.0	34.1		
	6	50.7	69.7	7.0	58.3	91.3	40.1		
30	2	42.8	63.3	4.5	56.3	95.3	28.4		
	3	45.2	65.7	5.3	58.5	97.5	30.4		
	4	47.6	68.1	6.0	61.0	100.0	32.4		
	6	51.9	72.4	7.0	64.3	103.3	44.4		
	8	56.4	76.8	8.3	67.0	106.0	49.4		
36	3	46.4	68.4	5.3	64.5	109.5	34.1		
	4	48.8	70.8	6.0	67.0	112.0	36.1		
	6	53.1	75.1	7.0	70.3	115.3	39.1		
	8	57.6	79.6	8.3	73.0	118.0	41.1		
	10	62.1	84.1	9.5	77.0	122.0	60.1		
42	4	50.0	73.5	6.0	73.0	124.0	40.1		
	6	54.3	77.8	7.0	76.3	127.3	43.1		
	8	58.8	82.3	8.3	79.0	130.0	45.1		
	10	63.3	86.8	9.5	83.0	134.0	49.1		
	12	68.0	91.5	11.0	86.0	137.0	69.1		
48	4	51.0	76.0	6.0	79.0	136.0	44.5		
	6	55.4	80.4	7.0	82.3	139.3	47.5		
	8	60.0	85.0	8.3	85.0	142.0	49.5		
	10	64.4	89.4	9.5	89.0	146.0	53.5		
	12	69.2	94.2	11.0	92.0	149.0	55.5		





## SPECIALTY VESSELS

## Automatic Backwashing Filtration System

There are many advantages to our Automatic Backwashing Systems.

- Reduces process/system downtime
- Reduces operator exposure
- Reduces maintenance cost
- Reduces waste fluid
- Reduces filter element disposal and replacement cost
- Increases productivity

Self-cleaning filters represent the ideal situation and provide the most productive and labor free solution. Matrix Products' ABW is unique because our patented technology backwashes with the lowest volume of liquid. This is achieved by using air to create the shear velocity needed to effectively clean the filter with the clean liquid inside each housing chamber.

### FLEXIBLE AND VERSATILE

Flow rates to several thousand GPM can be easily accommodated. To meet space requirements various configurations are available. Micron ratings from 2 microns are possible in sintered porous metal, wedge wire, and nylon filter bags. Continuous flow is maintained by taking one station off line while the rest continue operating.

### SINGLE VS DUAL STATIONS

On systems with flow rates less than 400 GPM our standard is "single station" systems which means each housing is a station. Larger systems use a "dual station" approach which has two housings per station. The two housings share a common manifold which allows a reduction in valves and, during backwash, two housings at a time (1 Dual Station) go off-line for cleaning.



### APPLICATIONS

The ABW is being used in many industries throughout the USA as well as overseas in such places as Argentina, Taiwan, Chile and Venezuela.

**Industries served include:** Automotive - Steel - Petroleum - Chemical - Pharmaceutical - Electronics - Nuclear Power - Superfund Sites - Groundwater & Soil Remediation - Commercial Laundries - Entertainment - Food - Mining - Detergents - Paper

**Applications include:** Cooling Towers - Coolants - Membrane Protection - Sulfuric and other Acids - Harvesting Steroids - Oil Reclamation - Potable & DI Water - Bottling Plants - Food Processing - Recycling - Decorative Ponds

### TURNKEY SYSTEMS

Our systems have included air compressors, pumps, power distribution boxes, motor starters, climate controlled enclosures, heat trace and air dryers, all skid mounted and ready for installation.





## How It Works

Fluid is introduced through the bottom of the filter housing. It is then forced through a filter element where the contaminant is captured on the outside surface of the filter. The clean fluid exits through the outlet. A controller monitors the differential pressure across the filter. When enough contaminant collects on the element and the differential pressure reaches a pre-selected point ( $\Delta P$ ), the backwash sequence is initiated. The backwash is accomplished by automatically shocking the filter with air and forcing the dirty fluid through the waste outlet. There is no introduction of additional fluids to contaminate the process, and the volume of liquid discharged is held to a minimum, reducing disposal costs. When the backwash operation is completed, the system returns on-line, the controller resets itself, and the whole process begins again.

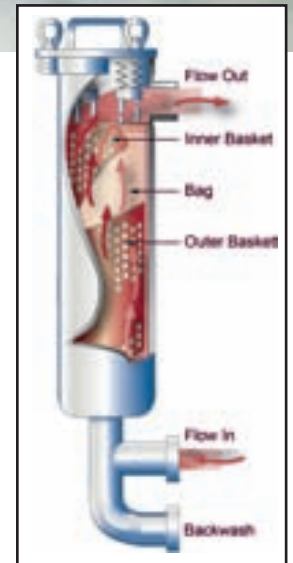

## Media Characteristics

This information is intended to be used as a general guideline. Since some characteristics are very similar from one media to the next, you should choose the media whose advantages best fit your particular filtration requirements. Consult Matrix for assistance in selecting the proper media for your application.

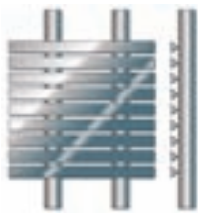

Wedge Wire (WW) or slotted, is the most durable of all backwashable media. They are strictly limited to .001" slot or 25 micron as the lowest retention rating. Wedge wire is particularly suited for critical low maintenance applications. As a result of their construction, they are used in many instances where manual cleaning is necessary but might damage other types of media.

MICRON RATING	OPENING (INCH)	% OF OPEN AREA
25	.001	2.1
50	.002	4.2
75	.003	6.1
150	.006	11.5
250	.010	18.0
350	.014	23.0



Poroplate® filter media is made from layers of stainless steel wire cloth diffusion-bonded together to form a rigid porous metal laminate structure. Poroplate filter media is corrosion resistant, cleanable, and can withstand high temperature applications up to 800°F. Micron ratings from 2 to 150 are available.

MICRON RATING	NOMINAL RATING	ABSOLUTE RATING
10	2μ	10μ
25	10μ	20μ
50	20μ	40μ
75	40μ	70μ
100	100μ	100μ
150	150μ	150μ

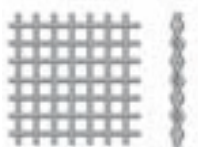

Nylon monofilament provides exceptional backwash efficiency. It exhibits a wide range of retention ratings. Nylon media should be considered for the filtration ranges of 25-75 microns. Filter bags have a defined cycle life.

MICRON RATING	% OF OPEN AREA
75	43
50	36
25	33

## How To Order

Build an ordering code as shown in the example.

**Example:** ABW 8 30 D 2F 1 4 S 15 S E B B 25 E C

**AUTO BACKWASHING FILTER**

**MODEL NUMBER**  
8 = 8

**BASKET DEPTH**  
30-inch (std.) = 30

**STATION TYPE**  
Single = S  
Dual = D

**VALVE SIZE**  
2-inch 150 class ANSI flange = 2F  
3-inch 150 class ANSI flange = 3F  
4-inch 150 class ANSI flange = 4F

**NUMBER OF STATIONS**  
One = 1  
Two = 2  
Three = 3  
Four = 4  
Five = 5  
Six = 6  
Seven = 7  
Eight = 8  
Nine = 9  
Ten = 10

**HEADER PIPE SIZE**  
2-inch = 2  
3-inch = 3  
4-inch = 4  
6-inch = 6  
8-inch = 8  
10-inch = 10  
12-inch = 12

**ASME CODE STAMP**  
C = Code

**CONTROL SYSTEM**  
E = Electric

**MICRON RATING**  
10 = 10 | 100 = 100  
25 = 25 | 150 = 150  
50 = 50 | 250 = 250  
75 = 75 | 350 = 350

**MEDIA**  
WW = Wedge wire  
PS = Sintered  
B = Bag style

**VALVE SEATS**  
B = Buna-N  
M = Ethylene propylene  
T = Teflon®  
V = Viton®

**COVER SEAL**  
B = Buna N  
E = Ethylene Propylene  
V = Viton® Fluoroelastomer  
TEV = Teflon® Encapsulated Viton®  
TSW = Teflon® (solid white)

**HOUSING MATERIAL**  
C = Carbon Steel  
S = 304 Stainless Steel  
S6 = 316 Stainless Steel

**PRESSURE RATING**  
15 = 150 psi (NPT or flanged)

**HEADER PIPE STYLE**  
S = Single sided  
D = Double sided

- Flanges provided with the housing match the pressure rating of the vessel. Housings rated 150 psi have 150 class flanges. ANSI B16.5 Pressure-Temperature rating tables determine flange class for ASME housings.
- Higher pressure ratings available. Consult factory.

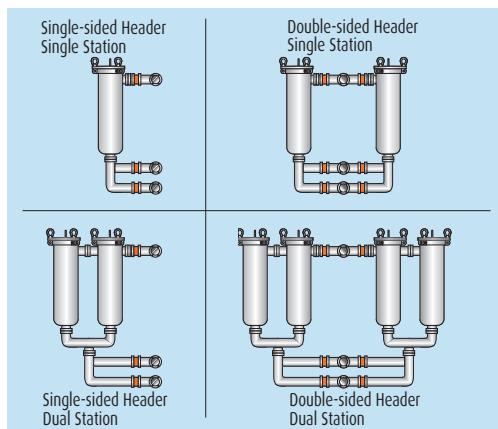

## Stations and Headers

Matrix offers both single and double-sided headers to conform to space restrictions. Header pipes have connections on one or on both sides. Each housing is separately controlled, increasing capacity while maintaining a high-level of control. A station has one set of controls, while accepting either one filter housing per station (a single station), or two housings per station (a dual station). Capacity is again increased, but the number of controls are minimized. By minimizing those controls, great savings are realized. For example, everything else being equal, a single-sided header with three dual-stations accommodates the same six housings and flow as a double-sided header with six single-single stations. However, there are three less controls on the dual-station unit, greatly reducing costs, perhaps as much as \$15,000.



# Multiplex Filters and Strainers From Matrix Separations, LLC

These high-capacity filters and strainers require no flow interruption for servicing

- For use with filter bags for filtering to as fine as one micron, or with perforated strainer baskets
- From 2 to 10 Model 8 housings are mounted in parallel to inlet and outlet manifolds
- Each unit has inlet and outlet valves, gauge ports, and a drain port, to permit servicing one at a time
- These are completely packaged free-standing systems in carbon steel and stainless steel



Standard Model 8 Triplex



Special Multi-Bag Multiplex

## Dimensions (IN)

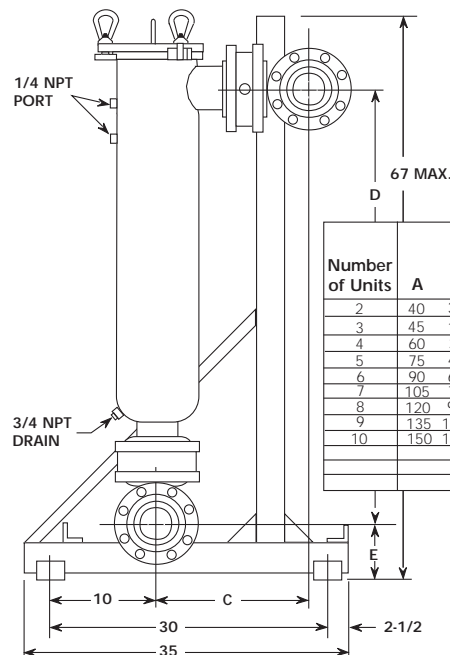
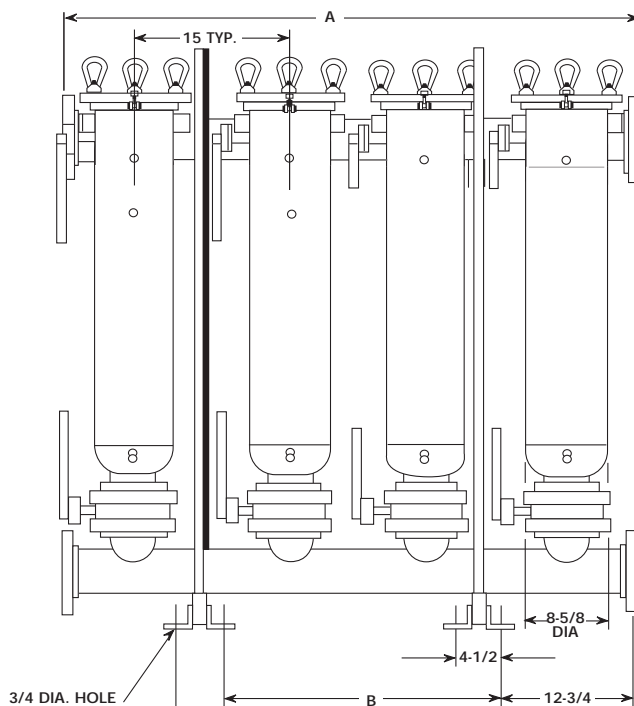

Number of Units	A	B	Inlet-Outlet Header Size	Valve Size	C	D	E
2	40	30	3	2	14.9	45.9	5.5
3	45	15	3	3	15.1	46.4	5.5
4	60	30	3	4	N/A	N/A	N/A
5	75	45	4	2	15.7	46.7	6.0
6	90	60	4	3	15.8	47.1	6.0
7	105	75	4	4	17.2	48.7	6.0
8	120	90	6	2	16.7	47.7	7.1
9	135	105	6	3	16.8	48.1	7.1
10	150	120	6	4	17.9	49.7	8.1
			8	3	18.1	49.4	8.1
			8	4	19.4	50.9	8.1

## How It Works

Build an ordering code as shown in the example.

**Example:** M8 30 10 8F 4 15 C B S M 200 D C 2M 50

	Housing				Options								OPTIONAL INNER BASKET		
<b>MODEL NO.</b>	M8	30	10	8F	4	15	C	B	S	M	200	D	C	2M	50
Multiplex = M8-30															
<b>NUMBER OF HOUSINGS</b> 2, 3, 4, 5, 6, 7, 8, 9, 10															
<b>PIPE SIZE (FLANGED)</b> 3-in. = 3F 4-in. = 4F 6-in. = 6F 8-in. = 8F															
<b>VALVE TYPE &amp; SIZE (INCH)</b> Butterfly type = 2, 3, 4															
<b>PRESSURE RATING</b> 150 psi = 15															
<b>HOUSING MATERIAL</b> Carbon steel = C 304 stainless steel = S 316 stainless steel = S6															
<b>COVER SEAL</b> Buna N = B Ethylene Propylene = E Viton® = V Teflon® Encapsulated Viton® = TV Teflon® (solid white) = TW															
<b>BASKET SEAL</b> Seal required = S															

**INNER BASKET, MEDIA SIZE**  
Perforation diameters (for type 2P baskets)  
1/4, 3/16, 9/64, 3/32, 1/16  
Mesh sizes (for type 2M and 2BM baskets)  
20, 30, 40, 50, 60, 70, 80, 100, 150, 200

**INNER BASKET, TYPE**  
No sym. = No inner basket  
2P = Perforated strainer  
2B = Filter bag\*  
2M = Mesh-lined strainer  
2BM = Mesh-lined filter bag

**ASME CODE STAMP**  
C = Code

**DISPLACER**  
D = Displacer

**OUTER BASKET, MEDIA SIZE**  
Perforation diameters (for type P baskets)  
1/4, 3/16, 9/64, 3/32, 1/16  
Mesh sizes (for type M and BM baskets)  
20, 30, 40, 50, 60, 70, 80, 100, 150, 200

**OUTER BASKET, TYPE**  
PB = Perforated strainer  
B = Filter bag\*  
M = Mesh-lined strainer  
BM = Mesh-lined filter bag

1. Flanges provided with the housing match the pressure rating of the vessel. Housings rated 150 psi have 150 class flanges. ANSI B16.5 Pressure-Temperature rating tables determine flange class for ASME housings.
2. Higher pressure ratings available. Consult factory.
3. Filter bags are ordered separately.



# Solids/Liquids Separators

## SPECIALTY VESSELS

### In-Line Separators for Industrial Applications

Use our centrifugal-action separator to remove grit, sand, metal chips, fines, and other solids from liquids. Perfect for use as a pre-filter to extend the life of fine filtration systems. These units require little or no maintenance, as there are no moving parts to wear out, or filter media to replace. The unit only requires a simple purging, eliminating downtime. For flows from 6 gpm and retention ratings to 50 micron.



### FEATURES AND OPTIONS

#### Features

- Low constant pressure drops
- Piped housings
- Carbon steel or stainless steel (304 or 316) construction for housings
- All housings are electropolished to resist adhesion of dirt and scale
- ASME code stamp available
- Pipe sizes 3/8 through 6-inch (larger sizes also available)

#### Options

- Different outlet connections
- Special materials

### TYPICAL APPLICATIONS

- Cooling towers
- Process water
- Food processing
- Chemical processing
- Well water
- Pulp & paper mills
- Mining operations
- Steel mills
- Petrochemical industry
- Power plants
- Protection of spray nozzles and other small orifices
- Chip removal from cutting coolants
- Car and vehicle wash systems
- Paint spray booths
- Heat exchangers
- Spray nozzle protection
- Industrial laundries
- Solids recovery
- Parts washing systems
- Pump protection
- Domestic Water
- Recirculating cooling water
- Sprinkler systems
- Quench water
- Pre-filter for seawater



**SPECIALTY VESSELS**

# How It Works

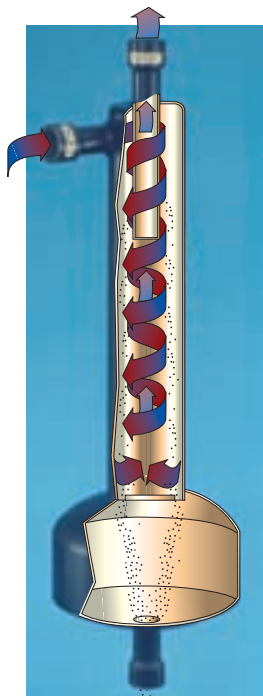

Fluid enters the pressure vessel tangentially at high velocity. A centrifugal action is created, which forces the solids to separate and enter the sump, while the clean liquid exits up through the standpipe. The solids collect in the sump, and can easily be purged. The operation is so simple, it can be set to automatically purge on a timed interval.

FLOW RANGE – GPM					
Model No.	Pipe Size (inch)	5 PSID	10 PSID	CV Factor	Solids Cap.
SEP-6	3/8	3	6	1.8	.24 gal.
SEP-11	1/2	7	11	3.4	.24 gal.
SEP-25	3/4	15	25	2.5	.94 gal.
SEP-35	1	30	40	14	.94 gal.
SEP-75	1-1/4	55	75	25	.9 gal.
SEP-80	1-1/2	60	80	25	.9 gal.
SEP-130	2	90	130	41	.87 gal.
SEP-140	2-1/2	96	140	41	.87 gal.
SEP-275	3	200	275	85	1.04 gal.
SEP-553	4	425	553	175	7.81 gal.
SEP-1265	6	985	1265	400	16.26 gal.

Model Number	Pipe Size (inch)	Inlet/Outlet	Drain Size (inch)
SEP-6	3/8	NPT	1
SEP-11	1/2	NPT	1
SEP-25	3/4	NPT	1
SEP-35	1	NPT	1
SEP-75	1-1/4	NPT	1
SEP-80	1-1/2	NPT	1
SEP-130	2	NPT	1
SEP-140	2-1/2	NPT	1
SEP-275	3	NPT or Flanged	1
SEP-553	4	Flanged	2
SEP-1265	6	Flanged	2

**Separator Performance Chart**

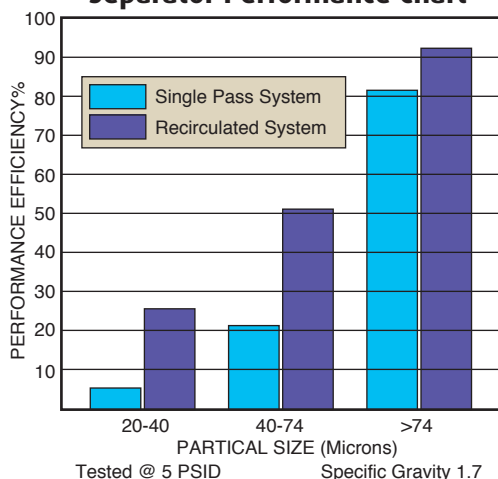

**Specific Gravity of Various Materials**

Material	Specific Gravity
Aluminum	2.7
Ashes (Coal)	2.0
Brass	9.0
Bronze/Copper	8.9
Carbon/Concrete/Lava	1.8-2.5
Coal (Anthracite)	1.3-1.9
Earth (Silt/Soil)	1.2-2.0
Glass (Crystal)	3.0
Granite/Gravel	2.5-3.0
Graphite	2.3
Iron	7.8
Lead	11.3
Limestone	2.8
Manganese	7.4
Nickel	8.9
Sand/Silica/Shale	2.6-2.8
Steel	7.8
Tin Ore	6.4-7.0

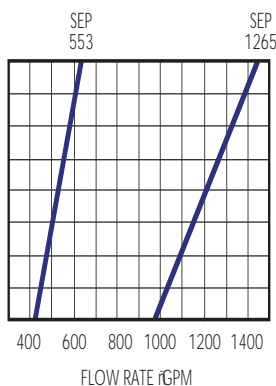
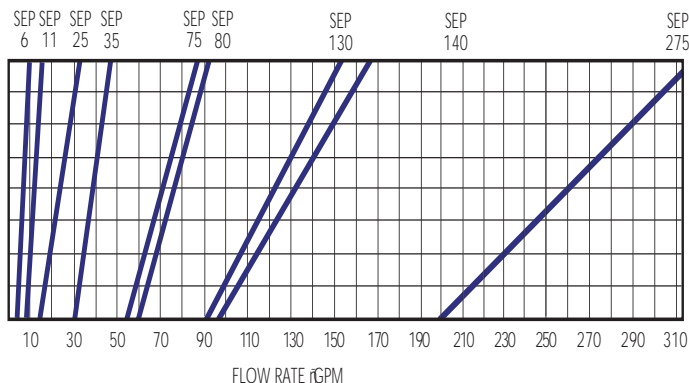

**Separator Sizing:**

Separators are generally sized so that there is at least a 5 PSID pressure drop across the unit. Separation efficiency increases as pressure drop increases. We've shown flow ranges for each unit based on 5 and 10 PSID. Choose a unit based on a flow/efficiency balance.

# Installation

## SPECIALTY VESSELS

The Separator should be installed in a near vertical position. The unit should be supported by means other than the inlet/outlet piping. First, connect the outlet of the unit to the outlet piping. Then install any supports, such as U-bolts or legs. Next, connect the inlet piping to the inlet. Test for leaks and separation. The unit is now ready for operation.

### PURGING AND MAINTENANCE

Separators must be purged regularly. If they are not, the separated solids will accumulate and overflow the collection area, affecting performance and contaminating effluent.

You can manually, automatically, or continuously purge the collection area of the separator. Manual purging requires that the operator open a simple valve and empty the contents. Automatic purging can be done many different ways, but the simplest is setting a timer to open and close the valve, purging the contaminant on a regular basis. Continuous purging simply requires leaving a manual valve partially open at all time, letting the contaminant leak out at a controlled rate. For best results, all purging should be done while the separator is in operation. Avoid purging “uphill” which will result in buildup and clogging, affecting performance and operation.

Simple rules of maintenance include checking the purge valve regularly for clogging, scale, and buildup. If the unit is installed in an area where the ambient temperature is below freezing, the collection area and all purge piping should be kept from freezing while operating. If left in idle state under freezing conditions, the entire unit must be drained of liquid, and the collection area must be purged of solids.

### Dimensions (IN)

Model	A	B	C	D	E
<b>SEP-6</b>	3.0	14.8	4.5	1.9	.6
<b>SEP-11</b>	3.0	14.8	4.5	1.9	.6
<b>SEP-25</b>	4.5	17.2	8.6	3.5	1.1
<b>SEP-35</b>	4.5	23.6	8.6	3.5	1.1
<b>SEP-75</b>	4.5	23.5	8.6	4.5	1.4
<b>SEP-80</b>	4.5	23.5	8.6	4.5	1.3
<b>SEP-130</b> (2")	4.8	22.6	8.6	6.6	2.1
<b>SEP-140</b> (2.5")	6	22.6	8.6	6.6	1.9
<b>SEP-275</b>	6.6	25.2	10.7	8.6	2.6
<b>SEP-553</b>	13.	45.2	18.0	12.7	4.1
<b>SEP-1265</b>	16.4	58.0	24.0	16.0	4.7

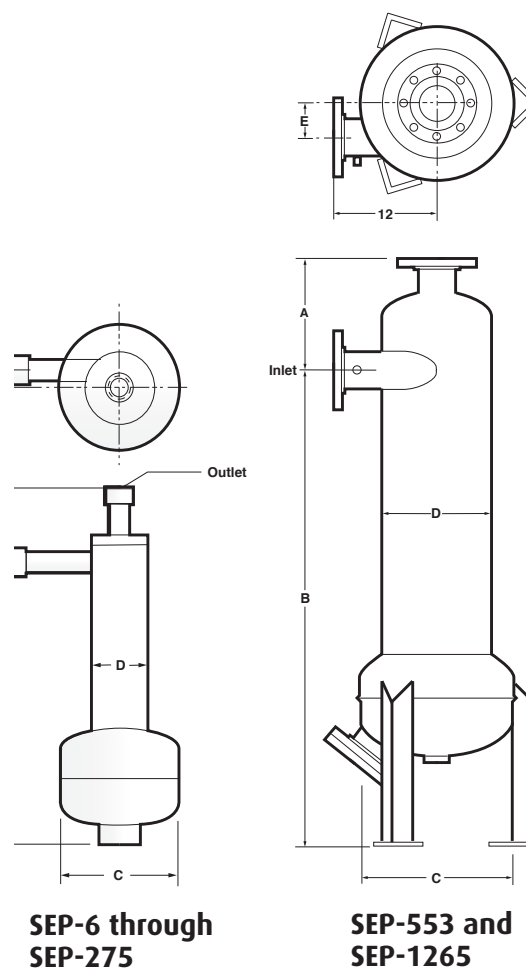

## How It Works

Build an ordering code as shown in the example.

<b>EXAMPLE:</b>		<b>SEP 275 3P 15 C C APV</b>			Options
<b>MODEL NO. AND FLOW RATE</b>					<b>OPTION</b>
6 GPM = <b>SEP-6</b>					<b>APV</b> = Optional APV Automatic
11 GPM = <b>SEP-11</b>					<b>P</b> = Manual purge valve
25 GPM = <b>SEP-25</b>					Leave blank for no purge valve
35 GPM = <b>SEP-35</b>					<b>ASME CODE STAMP</b>
75 GPM = <b>SEP-75</b>					<b>C</b> = Code
80 GPM = <b>SEP-80</b>					<b>HOUSING MATERIAL</b>
130 GPM = <b>SEP-130</b>					<b>C</b> = Carbon Steel
140 GPM = <b>SEP-140</b>					<b>S</b> = 304 Stainless Steel
275 GPM = <b>SEP-275</b>					<b>S6</b> = 316 Stainless Steel
553 GPM = <b>SEP-553</b>					<b>PRESSURE RATING<sup>2</sup></b>
1265 GPM = <b>SEP-1265</b>					<b>15</b> = 150 PSI (NPT or Flanged)
<b>PIPE SIZE, NPT, FLANGED<sup>1</sup></b>					
3/8-inch NPT = <b>3/8P</b> (SEP Model 6)					
1/2-inch NPT = <b>1/2P</b> (SEP Model 11)					
3/4-inch NPT = <b>3/4P</b> (SEP Model 25)					
1-inch NPT = <b>1P</b> (SEP Model 35)					
1-1/4-inch NPT = <b>1-1/4P</b> (SEP Model 75)					
1-1/2-inch NPT = <b>1-1/2P</b> (SEP Model 80)					
2-inch NPT = <b>2P</b> (SEP Model 130)					
2-1/2-inch NPT = <b>2-1/2P</b> (SEP Model 140)					
3-inch NPT = <b>3P</b> (SEP Model 275)					
3-inch Flanged = <b>3F</b> (SEP Model 275)					
4-inch Flanged = <b>4F</b> (SEP Model 553)					
6-inch Flanged = <b>6F</b> (SEP Model 1265)					

### NOTE:

- Flanges provided with the housing match the pressure rating of the vessel. Housings rated 150 psi have 150 class flanges. ANSI B16.5 Pressure-Temperature rating tables determine flange class for ASME code housings. Consult factory.
- Higher pressure ratings are available. Consult factory.



# Portable Filtration System

## SPECIALTY VESSELS

The Perfect choice for batch processing, or filtering from tanks or drums

This cart-mounted filter system has a diaphragm pump, pneumatic components and valves. The housing itself uses a standard cartridge. The clamp cover is easily removed and helps to reduce the time spent cleaning or replacing the cartridge. Matrix Separations superior side-entry design does not allow contaminant by pass around the filter cartridge nor fluid to impinge the filter cartridge. It also prevents the spills and messes caused when opening. So for efficient, clean filtration, Matrix Separations is your choice.

### BENEFITS

- Quick-opening covers that do not require special tools
- Carbon or stainless steel housings
- O-ring seals: Buna N, EPR, and Viton®
- 125 psi-rated housing
- 1-inch NPT ports
- Air-operated, double-diaphragm pump
- Poly-Pro pump (optional)
- Cart has built-in drip pan and 9" air-filled tires
- Compressed air filter/regulator
- 10-foot inlet/outlet hoses with quick-disconnect couplings
- 25 gpm flow rate
- Four wheel cart optional



## How It Works

Build an ordering code as shown in the example.

**EXAMPLE:**

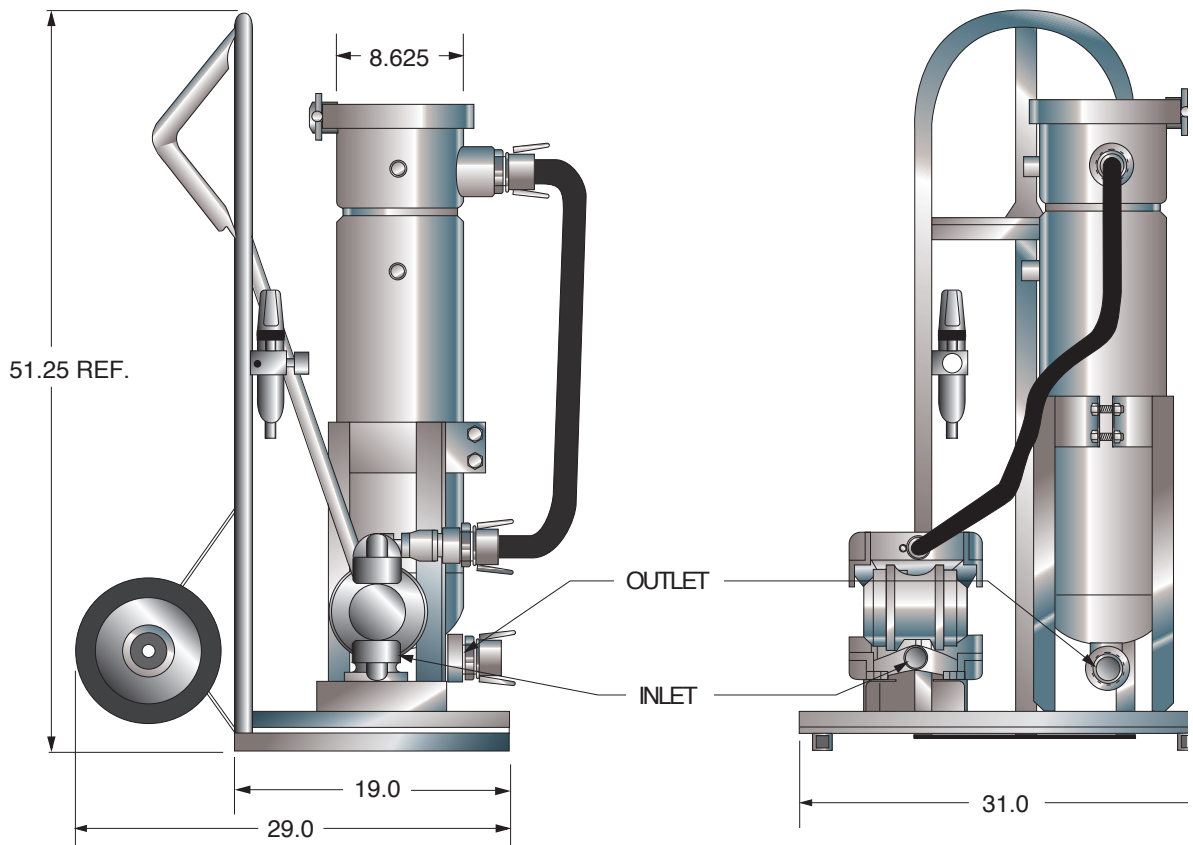
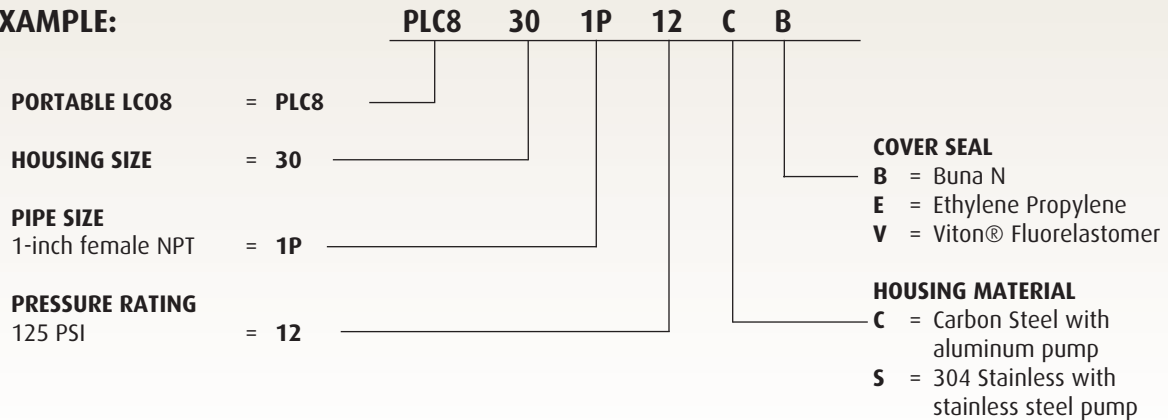

# Portable Filter Cart For Coolants and Metalworking Fluids

SPECIALTY VESSELS

## Rugged, Versatile, and On the Move ...

This versatile portable filter cart (PFC), is easily movable from machine to machine, holding tank to reservoir, or drum to tank. These two wheel hand truck systems provide a means for pre-filtering and transferring fluids. They are most effective controlling particulate problems before they cause damage to critical production equipment. Matrix PFCs' high-flow, industrial quality centrifugal pumps transfer fluids quickly and economically.

## APPLICATIONS

Portable filter systems can be used with coolants and other fluids with viscosities of 300 ssu or less that are compatible with aluminum and steel. Most new fluids are unfit for use in hydraulic and lube systems. Contamination enters the fluid during processing, mixing, handling and storage. Solid particulate may be present in unacceptable levels. Portable filter carts are the ideal means of pre-filtering and transferring these fluids. With a 1/2 horsepower motor and bag filter housing, this two wheel hand truck system is used for fluids with viscosities of 300 ssu or less.

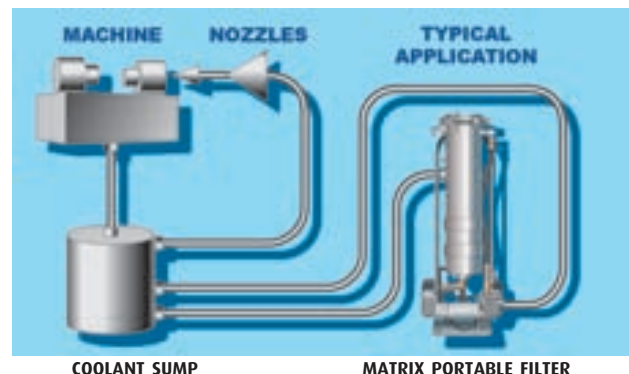

**SPECIALTY VESSELS**

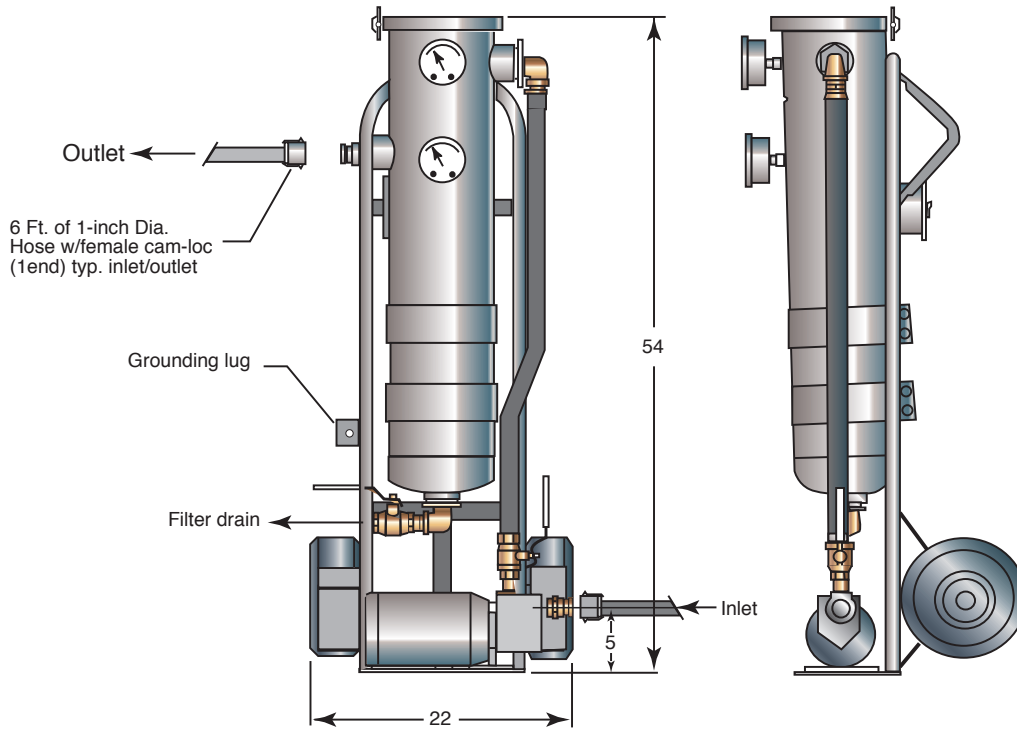

1" Self-Priming Centrifugal Pump Specs						
GPH of Water at Total Feet of Head*					Max. Head	
10ft.	20ft.	30ft.	40ft.	50ft.	Ft.	PSI
2280	1920	1440	900	360	57	25

(\*) Flow rate based on 1" pipe: flow rate and pressure will decrease with smaller pipe and/or base.

Portable Filter Cart – Ordering Code Example:			
	Housing		Options
Pre-Selected Example Code:	<b>PFC8</b>	<b>30</b>	<b>1P 125 C B PB</b>
Model No. =	PFC8		
Housing Size	30 inch = 30		
Pipe Size	1 inch female NPT = 1P		
Pressure Rating	125 psi = 125		
Housing Material	Carbon Steel = C		
Cover Seal	Buna N = B		
Basket Type	30 inch = PB		

Model 8 Suggested Bags — General Uses					
	PE	5	P	12	S
Fiber Rating					
Felt, Polyester =	PE				
Micron Rating (grade)*					
General Use =	5, 25				
Fine =	BB-12				
Very Fine =	BB-10				
Ultra Fine =	BB-1				
Bag Finish					
None =			P		
Bag Size and Dimensions					
8-3/8 x 32 =			12		
Bag Style					
Carbon Steel Plated Ring =				S	

# MATRIX

## SEPARATIONS



## STANDARD TERMS & CONDITIONS

**1. PRICING** — All price quotations are for prompt acceptance and subject to change without notice. Prices quoted are based on total quantities quoted. Increases or decreases in quantities may affect unit prices. Changes to design specifications regarding capital equipment may also affect unit prices.

Quoted prices are predicated on labor or straight time rates. Premium or overtime costs shall be added to prices quoted when overtime or weekend work is requested by customer.

All published price lists are subject to change without notice. List prices in effect at time of shipment will apply, unless otherwise specifically guaranteed.

All prices, quoted or list, are exclusive of sales, excise, federal, state, or local taxes now in effect and/or which may be later imposed.

**2. PAYMENT** — Standard payment terms for domestic orders are net 30 days, unless otherwise agreed upon and stated on invoice. Progress payments will be requested for all orders above a minimum of \$50,000.00, if quoted delivery is longer than six (6) weeks from receipt of that order.

Items quoted may, at Matrix Separation's option, be invoiced separately upon completion; or, if for reasons beyond Matrix Separation's control completion are delayed, the portion of work completed during any given month may be invoiced.

### Minimum billing for element sales is as follows:

Stocking Distributor, case quantities are our current requirement.

Drop Ship, case quantities.

Parts & Gaskets \$25.00 list per order - (if less than \$25.00 a Handling Charge of \$10.00 will be assessed)

**3. FREIGHT** — Standard freight terms are F.O.B. our manufacturing facilities. Orders for domestic customers will be shipped with freight charges collect at destination.

If quoted, any increase in freight charges on or after date of quotation shall be for customer's account. Quotation of freight charges is for shipment via least expensive means possible, unless specifically stated to contrary. Instructions resulting in higher transportation costs will be for customer's account.

**4. DELIVERY** — All shipping promises are estimated and cannot be guaranteed.

Delivery dates are based on factory workload, current economic conditions, and Matrix Separation's ability to secure labor, materials, and parts. Matrix Separation's shall incur no penalty for delay of shipment.

**5. EXPEDITED ORDERS** — All expedited orders are subject to expedited fee of 25% of the total cost of the expedited order.

**6. STORAGE** — Products ready to ship after the 45 day manufacture and hold policy, but stored at customer's request will be subject to storage charges. Matrix Separation's will invoice order upon completion; storage charges will be invoiced separately.

**7. CHANGE** — All customer requested order changes affecting price must be acknowledged by sending Matrix Separation's either a signed confirmation notice, facsimile, letter, or amended purchase order prior to order shipment.

Orders changed at customer's request may be subject to change order charges to cover the total administrative, engineering, and drafting time required for processing the charges.



## STANDARD TERMS & CONDITIONS

**8. CANCELLATION** — Orders once entered cannot be wholly or partially cancelled nor can specifications be substantially altered without payment of cancellation charges. Cancellation charges will be billed at a rate to insure against loss for labor or engineering performed, materials utilized, costs accrued, and other commitments up to time of receipt of written notice of cancellation or alteration.

**9. RETURN** — Products returned for credit will be subject to a 25% restocking fee. All products must be in new, and unused condition and packaged in the original boxes and available for resale. The freight to return any authorized products will be borne by the requesting entity. This must be authorized by Matrix Separation's prior to any return and must pass factory inspection upon receipt prior to issuance of credit.

**10. WARRANTY** — Matrix Separation's warrants to original customer that all of its products and parts thereof will be free from defects in material and workmanship under normal and proper use in service for which products are designed.

No implied warranties of merchantability nor implied warranties of fitness for a particular purpose shall extend beyond above warranty statement.

Matrix Separation's liability for damages caused by defective workmanship or material shall be limited to repairing or replacing defective parts. Matrix Separation's shall not be liable under any circumstances for loss of liquids, gases, or substances; nor for damage in transit; nor for any other direct or indirect consequential loss, cost, or damage of any nature.

**11. REPLACEMENT** — Replacement parts required by customer will be shipped and billed under normal terms. If customer desires to make a warranty claim, however, he shall notify Matrix Separation prior to making any repairs or alterations of any kind. Then, if instructed, customer must return original parts claimed defective to the factory by freight prepaid. Once factory inspection validates the claim, Matrix Separations will replace the defective parts without charge. Freight terms for warranty replacement parts are F.O.B. our manufacturing facilities and freight costs to and from factory will be for account of customer.

No warranty claims will be allowed resulting from any purchases, returned materials, labor done, materials used, or repairs or alterations to equipment made by customer without Matrix Separation's written consent.

**12. INSPECTION** — Customer inspection, if required, shall be performed at Matrix Separation's facilities. Any materials or equipment subsequently rejected after receipt by customer at destination may be repaired or replaced at Matrix Separation's option. All transportation and freight charges resulting will be for customer's account.

Factory orders which are held up due to customer delay in conducting in process and/or final product inspections are subject to customer inspection delay charges.

**13. EXCEPTION** — No change or modification of above standard terms and conditions will be recognized unless authorized in writing by the President of Matrix Separations, Mr. Ron Cloud.

## MATRIX SEPARATIONS

P.O. Box 16369

6000 Century Oaks Drive

Bonny Oaks Industrial Park

Chattanooga, TN 37416-6369

Phone 423.267.2397

Facsimile 423.267.0298

[www.matrixseparations.com](http://www.matrixseparations.com)

*The Premier Source  
for  
Filtration and Separation Products*





## THE MICRON RATING FOR MEDIA IN FLUID FILTERS

A micron rating for a fluid filter is a generalized way of indicating the ability of the filter's media to remove contaminants by the size of particles it is exposed to. The micron rating does not properly or fully describe either the efficiency or the contaminant-holding capacity of the filter media.

What does the word micron mean? The word micron is another term for micrometer (1 millionth of a meter). A micrometer is a unit of linear measure in the metric system used to measure distance from one point to another. It is used like the inch, foot, centimeter and millimeter to measure length, width or diameter of objects. Its scientific notation is  $\mu$ . Some linear equivalents are 1 inch is 25,400 microns and 1 micron is .000039 inches. Some comparative sizes are:

Diameter of average human hair 70 microns  
Lower limit of visibility (naked eye) 40 microns  
White blood cells 25 microns  
Talcum powder 10 microns  
Red blood cells 8 microns  
Bacteria 2 microns  
Carbon black 0.6 microns  
Tobacco smoke 0.5 microns

A filter that is marked or rated "10 micron" has some capability to capture particles as small as 10 micrometers. However, when you see a filter marked "10 micron", you do not know exactly what this means unless you also have a description of the test methods and standards utilized to determine the filter rating. The results from the different test methods may not be comparable as their methodology varies greatly.

The two most popular reported media ratings are a nominal micron rating (50%) and an absolute micron rating (98.7%). A nominal rating usually means the filter's media can capture a given percentage of particles of a stated size. For example, a filter might be said to have a nominal rating of 50% for particles 10 micrometers in size or larger. An absolute micron rating can be determined by single-pass or multi-pass testing and is usually obtained by passing a test fluid containing particles of a known size through a small, flat sheet of filter media.

Any particles that pass through the media are captured and measured. An absolute rating is also expressed in the form of a percentage of the size of particles captured.

Until recently, there has not been one universally accepted test method to measure or describe the media pore size or the size of particles a filter media can capture and hold. Depending on which test method was used, the same filter media could be rated with different micron ratings, thus leading to confusion regarding how well the filter's media actually performs. Fortunately, there now exists a test procedure called multi-pass testing or Beta ratio testing ( $\beta$ ) which is, a universally accepted test method that yields readily comparable test results. Multi-pass testing has been recognized by SAE (SAE J1858), ISO (ISO 4548-12, lube oil and ISO16889, hydraulic or fuel), ANSI (American National Standards Institute) and NFPA (National Fluid Power Association).

Multi-pass testing uses a specified contaminant, of known sizes, added regularly in measured quantities to the fluid which is pumped continuously through the filter. Measured samples of fluid are then taken at timed intervals from the upstream and downstream sides of the filter. The contaminant in the samples is measured for particle sizes and quantities of each size or range of sizes. From these upstream and downstream measurements, a Beta ratio is formulated by dividing the number of particles of a particular size in the upstream flow by the number of particles of the same size in the downstream flow. For example:

$$\beta_x = \frac{\# \text{ of particles upstream}}{\# \text{ of particles downstream}}$$

$$\beta_{10} = \frac{1,000}{500} \text{ or } \beta_{10} = 2$$

$\beta$  stands for Beta  
X represents the size of particle checked  
X(c) per ISO 16889

In this example, the equation provides the following infor-

## MICRON RATING FOR MEDIA IN FLUID FILTERS

mation: regarding 10-micrometer or micron size particles, the filter media tested has a Beta ratio of 2. This information is helpful but not useful without knowing what the ratio actually means. To translate the Beta ratio into meaningful information, subtract 1 from the original ratio and divide that answer by the original ratio. This answer represents the efficiency of the media at the specified particle size. For this example, take the Beta ratio of 2, subtract 1 from it and divide that answer by the original ratio of 2 or  $2 - 1 = 1 \div 2 = 50\%$  efficient at removing 10-micrometer or micron size particles. This formula is used to translate any Beta ratio into a percent efficiency at removing the size of particle tested. Here are a few Beta ratios and their corresponding efficiencies:

Beta Ratio	Efficiency
2.....	50%
10.....	90%
20.....	95%
75.....	98.7%
100.....	99%
200.....	99.5%
1000.....	99.9%

Beta ratio information can also be stated as  $\beta_{5/10/20} = 2/20/75$ . In this example, the media tested removed 50% of 5-micrometer or micron size particles, 95% of 10-micrometer or micron size particles and 98.7% of 20-micrometer or micron size particles presented to it. This same ratio information can also be stated as  $\beta_{2/20/75} = 5/10/20$ . Both equations state the same information in two different ways and are both accepted by the industry. Multi-pass testing provides an accurate, universally accepted, comparable test method to describe the efficiency of a media's ability to remove certain size contaminants. It can also determine the total contaminant holding capacity of the filter as well as some of its differential pressure capabilities. Its use eliminates the inaccuracies and confusion caused by the use of "micron ratings". For further information, see TSB 97-1R1, Hydraulic Filter Performance Criteria and TSB 04-2R1, ISO Updates to Multi-pass Liquid Filter Test Procedures.



# MATRIX SEPARATIONS



## GLOSSARY OF FILTRATION TERMS

### ABSOLUTE RATING:

Particle size in micrometers removed at a given efficiency under a manufacturer's defined test condition. Also an arbitrary term assigned by a manufacturer. Implied is 100%, but more often defined as 99%, 99.9%, 99.98%, 99.99% whatever suits the manufacturer. Typically (but not always) anything over 98% is considered absolute.

### ABSORB/ ABSORPTION:

The process of a fluid being taken into the pores of a solid.

### ACTIVATED CARBON:

Any form of carbon characterized by high adsorbive capacity for gases, vapors or colloidal solids. Carbon whose pores have been expanded for maximum adsorption capacity.

### ADSORB/ ADSORPTION:

To collect and hold a fluid on the surface of a solid. To adhere to a surface.

### AEROSOL:

A liquid or solid particle suspended in air, gas, or vapor.

### AMBIENT:

Surrounding. For example, ambient operating temperature of a vessel is temperature essentially the same as that surrounding the vessel.

### AMINE:

A class of organic compounds of nitrogen that may be considered as derived from ammonia. May be a gas, liquid, or solid. All amines are basic in nature and will usually combine readily with hydrochloric or other strong acids to form salts. In natural gas processing, typically used to strip 'sour' gas components.

### AREA:

The available apparent surface exposed to the flow of a fluid for maximum utilization. Function of area in filtration is related to initial pressure drop, rate or flow, and solids retention capacity. In many applications, proper utilization of area of media produces greater efficiency and solids retention.

Does not accurately represent 'depth' style cartridges.

### ATMOSPHERIC PRESSURE:

The pressure of approximately 14.7 pounds per square inch exerted at sea level in all directions by the atmosphere.

### BACKWASH:

To reverse flow of air, steam, or fluid through the media to effect solids removal; to wash away solid or semi-solid contaminant from filter media. Sometimes referred to as blowback.

### BATCH:

The quantity of material prepared or required for one operation. Example: a batch may be exemplified as a discontinuous process, such as batch processing of paint, soap, etc.

### BETA RATIO:

The ratio of the number of particles of a given size and larger upstream of a filter to the number of particles of the same size and larger downstream. Efficiency of a filter media is derived directly from Beta ratio.

Beta Ratio	% Efficiency
1	0
2	50
4	75
5	80
10	90
20	95
50	98
75	98.67
100	99
1000	99.9
5000	99.98
10000	99.99

### BLINDING:

Where filtered-out particles fill the openings or pores in the medium to the extent of shutting off the flow of product; the loading up of the medium so as to reduce capacity. Also referred to as blocking or plugging.

### BRIDGING:

Condition of filter loading where contaminants span the open space between adjacent sections of a filter medium, thus blocking a portion of the useful filtration area.

## GLOSSARY OF FILTRATION TERMS

### **BUBBLE POINT:**

Pressure drop in inches of water required to expel the first steady (continuous) stream of bubbles (fizz point) from a horizontal disc of wetted filter medium or a filter cartridge immersed in a liquid (usually alcohol).

### **BUBBLE POINT TEST:**

A commonly used non-destructive method to test the integrity of cartridge construction, to compare relative porosities of filter media, or as a quality control method to monitor product consistency.

### **BURST PRESSURE:**

The maximum differential pressure a cartridge will safely withstand when flow configuration is inside to outside.

### **BYPASS:**

Fluid flowing through a passage other than through the filter media. Leakage around filter media seals.

### **CARTRIDGE:**

Medium used in a vessel to perform the function of coalescing, filtering, or separating. Also referred to as element, media, repack, etc. Made in a specified physical shape, to be mounted by use of hardware designed for that purpose.

### **CATALYST:**

A substance which accelerates a chemical reaction without itself taking part in the reaction. For example, alkylation will not take place unless some substance such as sulphuric acid is present; such a substance is called a catalyst.

### **CAUSTIC:**

A class or name given to a group of chemicals, usually caustic soda or sodium hydroxide. A substance which has the power to burn, corrodes, or eats away. Used in chemical manufacturing, petroleum refining, pulp and paper, detergent, soap, textile, and vegetable oil refining.

### **CELLULOSE:**

The preponderant and essential constituent of all vegetable tissues and fibers. Basic in the textile and paper making industries. Three types exist in alpha-cellulose, beta-cellulose, and gamma-cellulose. Material used in filter media is bound by impregnation, usually a phenolic resin. Process of manufacturing controls the basic weight and pore size to specification. Filter paper, when impregnated with other properties, produces an excellent hydrophobic membrane which is non-water wetting and is used in the second stage of two stage separation/filtration equipment. Ideal cellulose material provides for a variety of filtration efficiencies, low initial pressure drop, high wet strength, and solids retention.

### **CENTIPOISE:**

One one-hundredth of poise. A poise is the unit of viscosity expressed as one dyne per second per square centimeter. At same flow rate, higher viscosity results in higher pressure drop across filter media and vice versa.

### **CENTISTOKE:**

One one-hundredth of a stoke. A stoke is equal to the viscosity in poises times the density of the fluid in grams per cubic centimeter.

### **CHANNELING:**

Tendency for process fluid and contaminant to pass through a low density area of an inconsistent filter medium or around cartridge seal points.

### **CLARIFICATION:**

Filtration of liquids containing small quantities of solids (purification).

### **CLASSIFICATION:**

A condition in which the larger particles settle out below the finer ones. Also referred to as stratification. May also be referred to as the action to sort out particles by various size groups or to some other established criteria.

### **CLEAN PRESSURE DROP:**

The differential pressure (drop) across a filter medium, measured in pounds per square inch (psi) or kilo Pascal's (kPa) at rated flow on new elements with clean product.

### **COALESCER:**

A mechanical device which unites discrete droplets of one phase prior to being separated from a second phase. Can be accomplished only when both phases are immiscible. Requires a tight media which is preferentially wettable and, by its nature of being tight, the media is also a good filtering material. Good coalescing permits gravity separation of the discontinuous phase. Coalescing may be accomplished by only a coalescer cartridge when the specific gravities of the two phases are varying widely. (As the gravities difference becomes less, the two stage principle is generally required where finely coalesced discontinuous droplets are repelled by the second stage separator cartridges. ONLY FOR WATER APPLICATIONS)

### **COALESCING:**

The action of uniting small droplets of liquid preparatory to its being separated from another liquid or gas. To grow.

### **COLLAPSE PRESSURE:**

Differential pressure across a filter cartridge or bag, great enough to cause it to collapse, with outside to inside flow configuration.



## GLOSSARY OF FILTRATION TERMS

### COLLOIDS:

Suspension of submicron particles in a continuous fluid medium that will not settle out of the medium.

### COMPATIBILITY:

Capability of two or more materials or substances to be used together without ill effect. A factor that must be considered when choosing the filter medium to be used with any fluid stream.

### CONCENTRATE:

Material to be filtered. Also referred to as feed, influent, intake, liquor, mud, prefillt, pulp, slimes, or sludge.

### CONDENSATION:

The process of cooling a vapor below its boiling point in order for it to be liquefied.

### CONTAMINANT:

The foreign, undesired matter in a fluid which is accumulated from various sources such as system dirt, residue from wear of moving parts, atmospheric solids which settle in an open system. Among others, contaminants tend to discolor a liquid, cause additional wear on moving parts, cause system upsets in process streams, or reduce the efficiency of a fluid. The presence of contaminants, whether liquid, solid or semi-solid, is the basis on which the use of filters or separator is sought.

### CORE:

Material used for the center of an element; generally of the wound design, to improve its structural integrity. May also be called a center tube when used in the coalescer, separator, or other type of filter element. May also be a tube of fibers formed into an element which has sufficient strength so as to provide its own center core.

### CORROSION:

The conversion of metals into oxides, hydrated oxides, carbonates, or other compounds due to the action of air, water, or both. Salts and sulphur are also important sources of corrosion. Removal of solids and water reduces the effect or speed of corrosion in many cases; and in other cases, corrosion inhibitors (chemicals) are used to reduce the effect of corrosion

### CYCLE LENGTH/ FILTER LIFE:

The duration, measured in time or volume that a filter can operate effectively between replacement and/or cleaning.

### CYCLONE:

Liquid or gas separation device that uses the principle of centrifugal force, which causes the contaminant to settle to be removed from process fluid without the use of filter media.

### DEHYDRATION:

Removal of water or hydrocarbon in vapor form from air or gas; Also water from another immiscible liquid. Differs from entrainment removal in that the dew point of a gas stream will be lowered by vapor removal. A form of purification.

### DENSITY:

Compactness or thickness; ratio of weight of a medium to the weight of an equal volume of fiber. In general, mass per unit volume, usually expressed in grams per cubic centimeter or pounds per cubic foot.

### DEPTH MEDIA:

Generally a filter medium that is thick and provides graded density construction. Any contaminant is trapped within the media rather than only on the surface.

### DEPTH TYPE FILTRATION:

Filtration accomplished by flowing a fluid through a mass filter media providing a tortuous path with many entrapments to stop the contaminant within the depth of the media. Flow may be cross flow such as from the outside to inside and then down the center of an element. Certain types of solids, or combinations of solids, do not lend to surface filtration where depth type filtration is found to be more suitable.

### DESICCANT:

A drying agent or medium used in dehydration of air, gas, or liquids. Examples: silica gel, activated alumina, molecular sieve, etc.

### DEW POINT:

Temperature at which air is saturated with moisture or in general the temperature at which a gas is saturated with respect to a condensable component.

### DIFFERENTIAL PRESSURE/ PRESSURE DROP:

Difference in pressure between two points in a system. In filters, this is usually measured between the inlet and outlet of the filter housing (typically this is a determining factor of filter service life).

### DIRT HOLDING CAPACITY:

The volume of contaminant a filter medium can hold before reaching the maximum allowable pressure drop. Volume will vary depending on the size and design of the element and the density of the solid particles. Usually reported by weight such as grams or pounds per element. Also called solids retention or solids holding capacity.

### DISPOSABLE:

Describes element which is to be discarded after use and replaced with an identical element. Same as replaceable. Opposite of reusable.

## GLOSSARY OF FILTRATION TERMS

### **DOUBLE OPEN END (DOE):**

Filter cartridge configurations such that both ends are open and require housings with knife edge sealing devices.

### **DOWNSTREAM:**

Portion of the product stream which has already passed through the system, or the portion of a system located after a filter, separator/filter, etc.

### **DROPLET:**

A minute drop which mates to form larger drops capable of falling by gravity.

### **EFFICIENCY:**

The ability of the filter medium to remove particles from the fluid stream, typically expressed as a percentage.

### **EFFLUENT/FILTRATE:**

The fluid that has passed through a filter.

### **ELEMENT:**

Medium used in a vessel to perform the function of coalescing, filtering, or separating. Also referred to as a cartridge.

### **ELEMENT SUPPORT PLATE:**

A cartridge mounting plate. (sometimes incorrectly referred to as Tube Sheet)

### **EMULSION:**

A suspension of small droplets of one liquid in a second liquid with which the first will not mix (two immiscible liquids).

### **END CAPS:**

Components adhered to ends of an element with adhesive or by other means to contain medium in the form designed for the element.

### **EXTRACTABLES:**

Inorganic or organic elements or compounds in the filter medium that have leached into the filtrate. Usually reported by weight or percent.

### **FDA:**

The filter media and support components must comply with FDA (Food and Drug Administration) regulations on materials that will come in contact with foods, beverages, drugs or cosmetics. Does not imply any special design features for filter housings nor performance difference than non-FDA products.

### **FIBER:**

The fundamental unit comprising a textile raw material such as cotton, wool, etc. Fibers may be elongated, single celled seed hairs like cotton; elongated, multicellular structures like wool; aggregations of elongated cells like flax; short sections of continuous filaments like a rayon staple and glass. Fibers have a length which is many times as great as their diameter. In order to be spun into a yarn, fiber must possess sufficient length, strength, pliability, and cohesiveness.

### **FIBERGLASS:**

A term used to describe a variety of products made of or with glass fibers.

### **FILTER:**

A term generally applied to a device used to remove solid or semi-solid contaminant from a liquid or gas, or separate one liquid from another liquid or gas. A filter, as referred to in the industry today, is limited to a device which removes solid and semi-solid contaminants only. If a device is used to remove solid and liquid contaminant, it is referred to in general terms as a separator, separator/filter, or entrainment separator. A filter may be one of a number of such types as: replaceable cartridge, cyclone, edge, leaf, baffle, plate and frame, precoat, centrifuge. The term filter is sometimes erroneously used to describe the media used inside the vessel or filter case. The correct term should be filter element, cartridge, etc.

### **FILTER/COALESCER:**

Single stage, vertical or horizontal vessel for coalescing and separating one immiscible fluid from another and the removal of solids. Generally recommended for use where continuous phase has a light gravity. Available with various efficiencies.

### **FILTER MEDIA:**

Plural of filter medium.

### **FILTER MEDIUM:**

The permeable material used to make a filter that separates particles from a fluid passing through it.

### **FILTER/SEPARATOR:**

A term used to describe a unit capable of separating two immiscible fluids while performing the dual function of filtering out solid contaminants. This device always consists of two stages of separation: cartridges in the first stage and a mechanical device in the second stage.

### **FILTRATION:**

The process of removing solid or semi-solid contaminant from liquid or gas by forcing them through a porous medium.



**FILTRATION EFFICIENCY:**

That fraction of suspended particles retained by the filter. Typically expressed as a percentage.

**FLASH POINT:**

The lowest temperature at which a combustible liquid will give off a flammable vapor which will burn momentarily.

**FLOW RATE:**

The volumetric rate at which a product is passed through a vessel or system generally expressed as gallons per minute, barrels per hour, barrels per day, actual or standard cubic feet per minute, hour, day, etc.

**FLUX:**

A relationship of flow to surface area; expressed as gallons per minute per square foot, meters cubed per square meter, etc.

**FULL FLOW:**

Product flow through the vessel at the rate for which the vessel is designed to operate. Also refers to all products passing through a medium. The opposite of a bypass filter which is designed to filter only a portion of the stream at a higher efficiency on a continuous basis.

**GAS SCRUBBER:**

A vessel designed to knock out liquid and associated solid contaminants from gas by impingement on a series of baffles or demister pads. A vessel specifically designed to remove liquid slugs from gas. Accomplished by drastic reduction of velocity as the gas enters the scrubber. Recent advances made in entrainment separation would expand the general use of the term to include mechanical cartridge type separators.

**GAUGE PRESSURE:**

Pressure greater than atmospheric pressure. Pressure readout from gauge without the inclusion of atmospheric pressure.

**GELS:**

A compressible or semi-solid material that can pass through filter media at an undefined and inconsistent degree. Best removed by depth medium.

**GLYCOL:**

A general term for a family of alcohols, clear, colorless, and soluble to varying degrees in water, alcohol, ether, benzene, etc. Has a wide range of usage such as coolants, antifreeze, and processes. Refer to specific type for further details.

In gas systems typically used to remove water entrained in gas.

**GRADED DENSITY:**

Variation in a cartridge that typically results in the filter medium being denser toward the core and less dense toward the outside surface. This is useful where a wide range of particle sizes exist because it allows larger particulate to be trapped toward the surface and smaller particles toward the core. Particularly useful for shear-sensitive contaminant such as iron sulfides.

**GRAVIMETRIC EFFICIENCY:**

Amount of contaminant removed by weight as determined by suspended solids analysis (ppm, mg/l).

**HOUSING:**

Container for filter cartridges or bags.

**HYDROCARBON:**

Any one of a large number of compounds composed primarily of elements carbon and hydrogen. As they increase in molecular weight and boiling point they may be respectively gases, liquids, or solids. Typically undesired in gas production.

**HYDROPHILIC:**

The tendency of a surface to wet with water (water loving).

**HYDROPHOBIC:**

The tendency of a surface not to wet with water (water hating).

**HYDROSTATIC TEST:**

A test conducted with water or other liquids at a given value over design pressure, to prove the structural integrity of a pressure vessel.

**I. D.:**

Inside diameter.

**IMMISCIBLE:**

Incapable of blending or mixing into a single homogeneous phase.

**IMPINGEMENT:**

Direct impact of particle or liquid upon the filter media.

**INITIAL DROP:**

Loss in differential pressure between two points upon the start of flow through a vessel using new elements.

**INFLUENT:**

Fluid entering the inlet of a filter or filter housing.



## GLOSSARY OF FILTRATION TERMS

### KNIFE EDGE SEAL:

A narrow, pointed ridge on the sealing surface of an end cap, center seal, or cartridge adaptor which provides a seal by "biting" into the cartridge gaskets.

### LAMINAR FLOW:

Flow rate at which liquid is in a non-turbulent state (typically 10 ft./sec. in liquid filtration) and should not be exceeded to maintain filtration integrity and consistency.

### LIFE EXPECTANCY:

The amount of use which may be expected from an element before it must be replaced; will vary according to the element's characteristics, the operating conditions, and the condition of the influent.

### LINE SIZE:

The size of line used to carry the product in a system, such as a six-inch line, etc.

### MEDIA (MEDIUM):

Material in a filter element that separates solids or semi-solid from fluid or two immiscible fluids.

### MEDIA MIGRATION:

Contamination of the effluent by fibers or other material of which the filter is constructed.

### MEDIUM:

The principal component of an element. A material of controlled pore size or mass through which a product is passed to remove foreign particles held in suspension or to repel droplets of coalesced water; or a material without controlled pore size such as glass fiber mats which contribute to filtration, coalescence, or separation of two immiscible liquids.

### MICRON:

Correct term is micrometer, which is one one-thousandth of a millimeter, or .000039 inches diameter. Human eye can see a 35 - 50 micrometer particle.

### MIST:

Visible water or hydrocarbon aerosol; floating or falling in fine drops.

### MMSCFD:

Million standard cubic feet per day.

### MMSCFH:

Million standard cubic feet per hour.

### MMSCFM:

Million standard cubic feet per minute.

### MSCFD:

Thousand standard cubic feet per day.

### MSCFH:

Thousand standard cubic feet per hour.

### MSCFM:

Thousand standard cubic feet per minute.

### MULTI-PASS PROCESS:

A process or system in which fluid is circulated indefinitely through a filter medium, e.g. engines, compressors, hydraulic equipment.

### NOMINAL:

An arbitrary term used to describe or define a degree of filtration. The filtration industry uses various methods of determining nominal ratings which are not necessarily interchangeable. Generally nominal references 90% removal of solids above a specified micron rating on a single pass basis.

### NOMINAL RATING:

Micron size removed at a given efficiency under a manufacturer's defined test condition. An arbitrary term assigned by a manufacturer. Generally 90% efficiency or less is said to be nominal, depending on manufacturer and product.

### O. D.:

Outside diameter.

### OPERATING PRESSURE:

The normal pressure at which a system operates.

### OPERATING PRESSURE, MAXIMUM:

The maximum pressure allowed in the system.

### OUTSIDE IN:

Flow of product from outside to inside of element.

### PAPER:

Medium used in many elements. A very general term applied to resin impregnated cellulose. Many types of paper or cellulose are used as filter media made to specifications.

### PARTICLE COUNT:

A practice of counting particles of solid matter in groups based on relative size. Frequently used in engineering a filter to specific task or to evaluate the performance of filter under specific operating conditions. When used as data to engineer a filter, proper consideration can be given the type of media to be used, expectant life of the media.



## GLOSSARY OF FILTRATION TERMS

### **PARTICLE REMOVAL EFFICIENCY:**

Removal of particles as a function of size as determined by counting individual particles, typically expressed in percent form.

### **PARTICLE SIZE DISTRIBUTION:**

A tabulation resulting from a particle count of solids grouped by specified micron sizes to determine the condition of either the influent or effluent stream. Usually expressed in percentage of total solids to the specific group.

Example: 31% in the 6 to 10 micron group. See particle count.

### **PERMEABILITY:**

The property of a filter medium that permits a fluid to pass through under a pressure differential (such as gpm/psi).

### **pH RANGE:**

An arbitrary scale of numbers from 0 to 14 indicating acidity or basicity of a solution. A neutral solution has a pH of 7; below 7 represents acidity, and above 7 represents basicity.

### **PIGMENT:**

A general term used to describe inorganic or organic, natural and synthetic chemical substances that are used to color paints, inks, etc.

### **PLEATED:**

Describes a physical form of a cartridge made into a convoluted form to resemble the folds in an accordion.

### **PLUGGING:**

Where filtered out particles fill the openings in the medium to the extent of shutting off the flow of product; the loading up of the medium so as to reduce capacity. Also referred to as binding or blocking.

### **POROSITY:**

A measure of the open area of a filter medium. Sometimes expressed as void volume.

### **PREFILTER:**

Filter for removing gross or large contaminant before the product stream enters a higher efficiency filter.

### **PRESSURE, ABSOLUTE:**

Gauge pressure plus 14.7 psi.

### **PRESSURE, ATMOSPHERIC:**

The force exerted by the atmosphere at sea level, which is equivalent to 14.7 psi.

### **PRESSURE, DIFFERENTIAL:**

The difference in pressure between two points, eg. Before and after a filter cartridge or filter vessel.

### **PRESSURE DROP:**

The difference in pressure (drop) across a vessel or cartridge, measured in pounds per square inch or kilo Pascals at rated flow on new elements with clean product.

### **PRESSURE DROP, MAXIMUM ALLOWABLE:**

The maximum allowed pressure differential across vessel or cartridge under specified product and flow conditions.

### **PRESSURE RELIEF VALVE:**

Valve which permits enough liquid or gas to escape from the vessel to prevent extreme pressure buildup within a vessel.

### **PSI:**

Pounds per square inch.

### **PSIA:**

Pounds per square inch absolute.

### **PSID:**

Pounds per square inch differential.

### **PSIG:**

Pounds per square inch gauge.

### **SCFD:**

Standard cubic feet per day.

### **SCFH:**

Standard cubic feet per hour.

### **SCFM:**

Standard cubic feet per minute.

### **SEPARATION:**

The action of separating solids, semisolids or liquids from fluids. May be accomplished by impingement, filtration, or by coalescing. The term "separation" is used in some circles when referring to the separation of liquids. Also used to describe the action in the second stage of two stage separation.

### **SEPARATOR:**

Vessel which is used to separate entrained liquids, semi-solids and solids from a gas stream. Typically of nominal filtration efficiency, the internals consist of a single stage vane, wire mesh or a cyclonic device. Not recommended for bulk liquid removal (see scrubber) or removal of high rate of solid contaminant.

## GLOSSARY OF FILTRATION TERMS

### SEPARATOR/FILTER:

Vessel which removes solids and entrained liquid from gas. Uses some combination of filter element in first stage and a mechanical separation device in the second stage such as vane, wire mesh or cyclones. A filter separator is always a two-stage vessel. Common application is the removal of water from gas or another immiscible liquid. General reference to term implies the equipment is capable of both separation and filtration to specific degrees of efficiencies.

### SERVICE LIFE:

The length of time an element operates before reaching the maximum allowable pressure drop or the time it is deemed as spent.

### SILICA GEL:

A regenerated adsorbent, consisting of amorphous silica. Used as a drying or dehumidifying agent for gases, liquids, or oils. Also used in certain types of packaging where moisture may be a problem.

### SINGLE OPEN END (SOE):

A filter cartridge configuration such that one end is sealed off by a closed end cap and the opposite end has a 222, 226 o-ring or other seal device. Used in housings that are designed to accept 222, 226 or other SOE cartridges.

### SINGLE PASS PROCESS:

A process in which a fluid passes through the filter medium only once before further processing.

### SPECIFIC GRAVITY:

Ratio of mass of a solid or liquid to the mass of an equal volume of distilled water, or of gas to an equal volume of air under prescribed temperature and pressure.

### SURFACE MEDIA:

A filter medium that is a thin cellulosic, microfiber or membrane material that due to its construction, generally provides high flow rate, low pressure drop, high efficiency, high surface area and high dirt holding capacity. Any solid contaminant is trapped on the surface of the media.

### SURFACTANTS:

Coined expression for surface active agents which are sometimes called emulsifiers or wetting agents. First appeared in hydrocarbons with the advent of the catalytic cracking process in refining. Caused by the forming of sodium sulfonate and sodium naphthanate molecules. Affects liquid/liquid separation by reducing interfacial tension and forming into a slime which blinds off the fibers used in coalescing media.

### SUSPENDED SOLIDS:

Mixture of solids suspended in a fluid. Expressed in weight or volume.

### THIXOTROPIC FLOW:

A fluid system where a range of viscosities can be measured at any given shear rate. The longer the material is sheared, the lower the viscosity until a lower limiting value is reached.

### THREE PHASE SEPARATOR/FILTERS:

Vessel which removes solids and entrained liquid from gas while separating two immiscible liquids within the same vessel. Generally uses cartridges in the first stage and a series of baffles, weirs and/or vanes in the second and third stages.

### THROUGHPUT:

Total volume of a fluid that passes through a filter before it must be replaced.

### TORTUOUS PATH:

Crooked, twisting, or winding path which tends to trap or stop solid particulate matter.

### TURBIDITY:

Measure of the amount of haze or cloudiness caused by fine particles in a fluid.

### TURBIDIMETRIC EFFICIENCY:

Percentage reduction of haze or cloudiness in a fluid.

### TURBULENT FLOW:

The flow rate at which laminar flow is exceeded and filtration performance is adversely affected.

### UNIFORM DENSITY:

Having the same weight per unit volume of filter media from the upstream (influent) to the downstream (effluent) side of the filter.

### UNLOADING:

Downstream release of trapped contaminant due to change in flow rate, mechanical shock and vibration, or as excessive pressure builds up; or media failure.

### UPSTREAM:

Portion of the product stream which has not yet entered the system.

### VAPOR:

A solid or a liquid in a gaseous form under normal conditions of pressure and temperature.

### VELOCITY:

The time rate of motion in a given direction and sense.

### VISCOSITY:

A measure of the resistance to flow of a liquid. Viscosity of a liquid varies appreciably with changes in temperature. Typically expressed in centipoise, centistoke or SSU values.

### WATER HAMMER:

Pressure surge produced when the linear flow of a non-compressible fluid is rapidly interrupted by devices such as fast-acting valves.





VESSEL DATA SHEET

**APPLICATION DATA SHEET**

*The Premier Source  
for  
Filtration and Separation Products*

COMPANY:  
CONTACT:  
PHONE:  
FAX:  
E-MAIL:

PROCESS DESCRIPTION:

PROCESS OPERATING DATA:

FLUID NAME & CHEMICAL COMPOSITION:

PH:

VISCOSITY:

SPECIFIC GRAVITY:

MEDIA DESIGN SPECIFICATIONS:

FLOW RATE (GPM):      MICRON REMOVAL RATING:

SOLIDS (PPM):      EFFICIENCY % :

TYPE OF CONTAMINANTS : BAG YES    CARTRIDGE YES

TYPE:

SIMPLEX YES:

DUPLEX YES QUANTITY:

DESIGN TEMPERATURE (°F):

MATERIAL OF VESSEL: IF OTHER, NAME:    DESIGN PRESSURE (PSD):

MATERIAL OF CLOSE O-RING: IF OTHER, NAME :

CONNECTION SIZE (IN.):

FLANGED:

NPT:

ASME CODE STAMP YES    MAXIMUM DIFFERENTIAL

GAUGES YES      PSI CLEAN      PSI DIRTY

REMARKS:

P.O. Box 16369

6000 Century Oaks Drive

Bonny Oaks Industrial Park

Chattanooga, TN 37416-6369





*The Premier Source*

*for*

*Filtration and Separation Products*

P.O. Box 16369

6000 Century Oaks Drive

Bonny Oaks Industrial Park

Chattanooga, TN 37416-6369

## CALCULATING TOTAL FILTRATION COST

- 1. ELEMENT PURCHASE COST \$ \_\_\_\_\_
- 2. FREIGHT COST \$ \_\_\_\_\_
- 3. DISPOSAL COST \$ \_\_\_\_\_
- 4. LABOR COST TO CHANGE ELEMENTS \$ \_\_\_\_\_
- 5. PROCESS DOWNTIME \$ \_\_\_\_\_
- 6. PRODUCT WASTE \$ \_\_\_\_\_
- 7. SERVICE LIFE \$ \_\_\_\_\_
- 8. PERFORMANCE BENEFITS \$ \_\_\_\_\_
- TOTAL** \$ \_\_\_\_\_

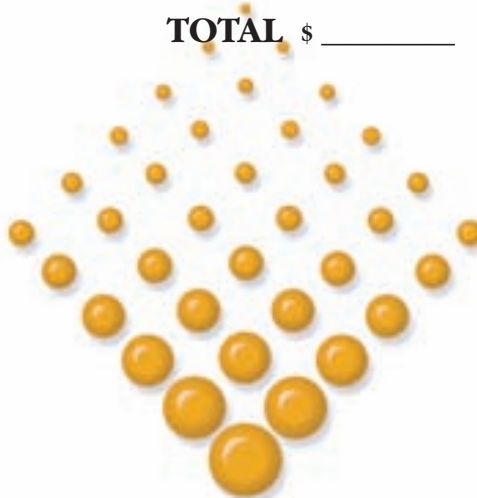

## HOW TO SELECT THE RIGHT FILTER

- 1. WHAT ARE YOUR FILTRATION OBJECTIVES?
- 2. WHAT TEST PROTOCOL DO YOU USE TO DETERMINE IF YOU HAVE MET YOUR FILTRATION OBJECTIVES?
- 3. LOOK AT THE SYSTEM TO DETERMINE WHAT TYPE OF FILTER WOULD BE COMPATIBLE WITH THE FLUID AND OPERATING TEMPERATURE
- 4. OPERATING PARAMETERS SHOULD DETERMINE THE NECESSARY MICRON RATING AND MATERIAL OF CONSTRUCTION
- 5. RECOMMENDATION, THE MOST ECONOMICAL FILTER TO MEET THE FILTRATION OBJECTIVES

Let the contaminant determine the level of filtration required

www.matrixseparations.com





*The Premier Source  
for  
Filtration and Separation Products*

P.O. Box 16369  
  
6000 Century Oaks Drive  
  
Bonny Oaks Industrial Park  
  
Chattanooga, TN 37416-6369

## **FILTRATION REQUEST FORM — GAS VESSEL**

**Contact information:**  
(name, address, telephone, email)

**Name and geographic location of installation:**  
(ie. Badger Station in Edmond, OK)

**Project Name:**  
**Type of process:**  
(ie. NG processing plant, compressor station, etc.)

**Type of gas:**  
  
(please submit gas analysis if available or  
note anything special, ie. appreciable amount  
of H2S, CO2, H2, etc.)

**Location of equipment in the process:**  
  
(ie. Before a compressor, after a dehy, etc.)  
(flow rate, normal operating pressure and temp, specific gravity)  
**Design conditions:**

(MAWP, temp, corrosion allowance, NDE)  
**Type of contaminant?**

**Removal efficiency requirements?**

**Horizontal or vertical preference?**

**Any space limitations?**

**Instrumentation needed?**

**Comments/Other:.**



APPLICATION NOTES

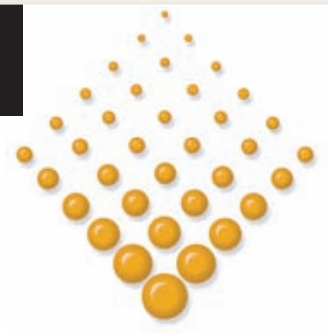

**MATRIX**  
SEPARATIONS





## PROCEDURE FOR GATHERING SPENT ELEMENTS FOR ANALYSIS

The main reason for sending in a spent element for evaluation is for dissection and observations utilizing digital imaging and size particulate layer by layer to determine if the filter element being used is performing to specifications. A microscope is fitted with a sizing reticle for sizing particles at high magnifications. Particle sizing software is utilized to obtain counts, distributions, and sizing on multi-phase fluids that could not otherwise be done using conventional laser technology.

1. Spent element needs to be dry before packaging.
  - a. Handle with care so not to disturb contaminate imbedded in the element media.
  - b. Stand in an upright position to dry.
2. Package element in at least two plastic bags and seal the end of the bag opening.
3. One element per packaging.
4. Label element with:
  - a. Manufacture and element part number.
  - b. What the process fluid is, for this application.
  - c. Customer name
  - d. Location reference
  - e. Date
  - f. Initial differential pressure (dP)
  - g. Change out differential pressure (dP)
  - h. Length of service (element life: hours, days, months)
5. A copy of the MSDS document for the process fluid must accompany the spent element.
6. Package spent element / elements in a box packed with something that will not allow the element to roll around in the box.
7. Label box with "Test Elements".

**SHIP SAMPLES TO:**  
**MATRIX SEPARATIONS**  
6000 Century Oaks Drive  
Bonny Oaks Industrial Park  
Chattanooga, TN 37416-6369  
Attn: Lori Reid



APPLICATION NOTES

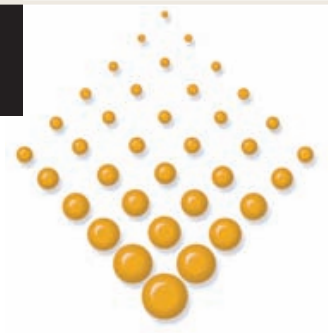



### EQUIPMENT RENTAL CONTRACT

This Equipment Rental (this "Rental") is made effective as of April\_\_ 2009, between Matrix Separations (the "Company"), 6000 Century Oaks Drive, Bonny Oaks Industrial Park, Chattanooga, Tennessee, 37416-6369, and \_\_\_\_\_ (the "Customer"),

\_\_\_\_\_, \_\_\_\_\_, \_\_\_\_\_, and \_\_\_\_\_, states the agreement of the parties as follows:

**RENTAL EQUIPMENT SUBJECT TO THIS CONTRACT.** The Company shall rent the equipment listed on the attached Exhibit "A".

**PAYMENT TERMS.** The rental payments shall be due whether or not the Customer has received notice of a payment.

**SERVICE CHARGE.** If any Rental installment is not paid within 30 day(s) after the due date, the Customer shall pay to the Company a surcharge of 1% of monies overdue per day. At this time the Rental will cease and the equipment shall be returned immediately to the Renter

**NON-SUFFICIENT FUNDS.** The Customer shall be charged \$250.00 for each check that is returned to the Company for lack of sufficient funds.

**SECURITY DEPOSIT.** The Customer shall pay a security deposit of 10% of the estimated value of the rental at the time that this Rental is signed. This deposit will be returned to the Customer at the termination of this Rental, subject to the option of the Company to apply it against Rental charges and damages. Any amounts refundable to the Customer shall be paid at the time this Rental is terminated. The security deposit shall not bear interest.

**RISK OF LOSS OR DAMAGE.** The Customer assumes all risks of loss or damage to the equipment from any cause, and agrees to return it to the Company in the condition received from the Company, with the exception of normal wear and tear. The Company or their appointed agent will determine normal wear and tear. All determinations made by the Company are final.

**INSURANCE AND INSURANCE CERTIFICATE.** The Customer shall insure the equipment for its full replacement value as stated in Appendix A under an ALL RISKS POLICY. A copy of the insurance certificate shall be provided to the Company prior to the commencement of the Rental. The sole beneficiary of the insurance will be stated on the certificate as Matrix Separations, 6000 Century Oaks Drive, Bonny Oaks Industrial Park, and Chattanooga, Tennessee 37416-6369. Failure of the insurance company to honor a claim in no way changes the obligation of the Customer to compensate The Company for the full new replacement value of the equipment. The minimum paid up term of the Insurance must be for the initial period of the Rental plus one-month.

**RENTAL TERM.** This Rental shall begin on the above effective date and shall terminate on return in fully working condition to the Company's facility. If the equipment has to be repaired to return it to a fully working state the equipment will continue to be Rented until it is repaired. The Rental period will end only when the equipment has been returned to a fully working state. At any time the Company has the right to terminate the Rental with 7 days notice. The Customer may terminate the Rental after the initial period of the Rental has been completed as defined in EXHIBIT C.

**CREDIT REFERENCES.** The customer will provide credit references prior to 1 week before the commencement of the Rental period. These will consist of

- Bank reference
- Three trade references where the value of recent credit history with those is of the same order of magnitude as is being requested by the Customer.

## EQUIPMENT RENTAL CONTRACT

**CARE AND OPERATION OF EQUIPMENT.** The equipment may only be used and operated in a careful and proper manner. Its use must comply with all laws, ordinances, and regulations relating to the possession, use, or maintenance of the equipment, including registration and/or licensing requirements, if any.

**MAINTENANCE AND REPAIR.** The Customer shall maintain the equipment in good repair and operating condition, allowing for reasonable wear and tear.

The Customer shall pay all costs required to maintain the equipment in good operating condition. Such costs shall include labor, material, parts, and similar items.

**COMPANY'S RIGHT OF INSPECTION.** The Company shall have the right to inspect the equipment during Customer's normal business hours.

**RETURN OF EQUIPMENT.** At the end of the Rental period, the Customer shall be obligated to return the equipment to the Company at the Customer's expense. Any freight, insurance or customs charges related to the rented equipment incurred during or at the end of the rental will be billed to the Customer's account.

**OPTION TO RENEW.** If the Customer is not in default upon the expiration of this rental, the Customer shall have first option to rent the equipment on such terms as the parties may agree at that time.

**ACCEPTANCE OF EQUIPMENT.** The Customer shall inspect each item of equipment delivered pursuant to this Rental. The Customer shall immediately notify the Company of any discrepancies between such item of equipment and the description of the equipment in the Equipment Schedule. If the Customer fails to provide such notice in writing within 2 day(s) after the delivery of the equipment, the Customer will be conclusively presumed to have accepted the equipment as specified in the Equipment Schedule. Any subsequent claim that the equipment was not provided in fully functional order will not be considered.

### FAILURE TO PERFORM

If the equipment fails to perform after the initial acceptance it will be the responsibility of the customer

to repair and correct the problem. The Company will not be held responsible for any failure of equipment for any reason and the equipment will remain on rental unless a dispensation is granted in writing by the Company to waive the rental fees for the period of non-performance. The company will not be held responsible for any errors or omissions due to the Customer's lack of operational or technical capability.

**OWNERSHIP AND STATUS OF EQUIPMENT.** The equipment will be deemed to be personal property, regardless of the manner in which it may be attached to any other property. The Company shall be deemed to have retained title to the equipment at all times, unless the Company transfers the title by sale. The Customer shall immediately advise the Company regarding any notice of any claim, levy, lien, or legal process issued against the equipment.

**WARRANTY.** The Company makes no warranties; express or implied, as to the equipment rented. The Customer assumes the responsibility for the condition of the equipment.

**INDEMNITY OF COMPANY FOR LOSS OR DAMAGES.** If the equipment is damaged or lost, the Company shall have the option of requiring the Customer to repair the equipment to a state of good working order, or replace the equipment with like equipment in good repair, which equipment shall become the property of the Company and subject to this contract.

**LIABILITY AND INDEMNITY.** Liability for injury, disability, and death of workers and other persons caused by operating, handling, or transporting the equipment during the term of this Rental is the obligation of the Customer, and the Customer shall indemnify and hold the Company harmless from and against all such liability. Customer shall maintain liability insurance of at least \$15,000,000.00 unless waived in writing by the Company.

**CASUALTY INSURANCE.** The Customer shall insure the equipment in an amount sufficient to cover the replacement cost of the equipment.



## EQUIPMENT RENTAL CONTRACT

**TAXES AND FEES.** During the term of this Rental, the Customer shall pay all taxes, assessments, and license and registration fees on the equipment.

**DEFAULT.** The occurrence of any of the following shall constitute default under this.

- A. The failure to make a required payment under this Rental when due.
- B. The violation of any other provision or requirement that is not corrected within 4 day(s) after written notice of the violation is given.
- C. The insolvency or bankruptcy of the Customer.
- D. The subjection of any of Customer's property to any levy, seizure, assignment, application or sale for or by any creditor or government agency.

**RIGHTS ON DEFAULT.** If the Customer is in default under this Rental, without notice to or demand on the Customer, the Company may take possession of the equipment as provided by law, deduct the costs of recovery (including attorney fees and legal costs), repair, and related costs, and hold the Customer responsible for any deficiency. The Company shall be obligated to re-rent the equipment, or otherwise mitigate the damages from the default, only as required by law.

**NOTICE.** All notices required or permitted under this Rental shall be deemed delivered when delivered in person or by mail, postage prepaid, addressed to the appropriate party at the address shown for that party at the beginning of this Rental.

**ASSIGNMENT.** The Customer shall not assign or sublet any interest in this Rental or the equipment or permit the equipment to be used by anyone other than the Customer or Customer's employees, without Company's prior written consent.

**ENTIRE AGREEMENT AND MODIFICATION.** This contract constitutes the entire agreement between the parties. No modification or amendment of this contract shall be effective unless in writing and signed by both parties. This contract replaces any and all prior agreements between the parties.

**GOVERNING LAW.** This contract shall be construed in accordance with the laws of the State of Tennessee.

**SEVERABILITY.** If any portion of this contract shall be held to be invalid or unenforceable for any reason, the remaining provisions shall continue to be valid and enforceable. If a court finds that any provision of this contract is invalid or unenforceable, but that by limiting such provision, it would become valid and enforceable, then such provision shall be deemed to be written, construed, and enforced as so limited.

**WAIVER.** The failure of either party to enforce any provision of this contract shall not be construed as a waiver or limitation of that party's right to subsequently enforce and compel strict compliance with every provision of this contract.

**CERTIFICATION.** Customer certifies that the application, statements, trade references, and financial reports submitted to Company are true and correct and any material misrepresentation will constitute default under this contract.

# EQUIPMENT RENTAL CONTRACT

Company:

Matrix Separations.

By: \_\_\_\_\_

Matt Cloud, Vice President

Customer:

\_\_\_\_\_

By: \_\_\_\_\_

\_\_\_\_\_

\_\_\_\_\_

## MATRIX SEPARATIONS TRIAL UNIT PROGRAM

- 1) User to pay all freight charges.
- 2) User to purchase all filter bags and gaskets from Matrix Separations' during the trial period.
- 3) Filter unit to be returned in working order. If necessary a clean up fee will be charged. Such a charge will be assessed at time of return dependant on the type of cleaning required.
- 4) Standard trial period is 30 days. A \$1700.00/month rental fee will be charged there after. Rental fee is 100% applicable toward purchase price, if purchased within 90 days. Rental fee applicability expires after 90 days.
- 5) Matrix Separations reserves the right to recall the filter unit anytime after 90 days.
- 6) Filter unit will be invoiced the day of shipment, however, collections will not begin until trial period expires.
- 7) A RGA # will be provided with the packing list. Please mark your package with this number. This will insure that your credit will be processed in a timely manner.

# MATERIALS SELECTION GUIDE

CHEMICALS	CONCENTRATE	TEMP deg F	MEDIA							CORES				VESSELS			
			COTTON	POLYPROPYLENE	RAYON	POLYESTER	NYLON	ACRYLIC	MODACRYLIC	FIBERGLASS	POLYPROPYLENE	TIN	304 S.S.	316 S.S.	CARBON STEEL	304 S.S.	316 S.S.
ACETALDEHYDE		250	0		0						X	0	0	0	0	0	
ACETALDEHYDE		120	0	0	0					0	X	0	0	0	0	0	0
ACETAMIDE		200	0			0	0				X			0			
ACETIC ACID	5%	200					0	0	0	0	X	0	0	X	0	0	
ACETIC ACID		100	0	0	0	0	0	0	0	0	X	0	0	X	0	0	0
ACETIC ACID	50%	180									X	0	0	X	0	0	
ACETIC ACID		70	0	0	0	0	0	0	0	0	X	0	0	X	0	0	0
ACETIC ACID	80%	180				0		0			X	0	0	X		0	
ACETIC ACID		70	0	0	0	0	0	0	0	0	X	0	0	X	0	0	0
ACETIC ACID	100%	180				0		0			X	0	0	X		0	
ACETIC ACID		70	0	0	0	0	0	0	0	0	X	0	0	X	0	0	0
ACETONE		250	0			0	0	0	X	0	0	0	0	0	0	0	
ACETONE		80	0	0	0	0	0	0	X	0	0	0	0	0	0	0	0
ACETONITRILE		70	70	70	0	70	70			0				X	0	0	70
ACETYL CHLORIDE		250							0			0	0	X	0	0	
ACETYLENE		250					0				0	0	0	0	0	0	
ACETYLENE		120	0	0			0				0	0	0	0	0	0	
ACRYLIC ACID		120		0							0	0	0	0		0	
ACRYLONITRILE		70	0	0	0	0	0	0			0	X	0	0	X	0	0
ACTOPHENONE		250				X	0										
ACTOPHENONE		120		X		X	0				X			0	0	0	X
ADIPIC ACID	5%	120	0	0	X		X	0	0	0	0			0	0	0	
AIR COMPRESSED		200	0		0	0	0	0	0	0	0	0	0	0	0	0	0
AIR COMPRESSED		120	0	0	0	0	0	0	0	0	0	0	0	0	0	0	0
ALCOHOLS			0	0	0	0	0	0	0	0	0	0	0	0	0	0	0
ALLYL ALCOHOL			0	0	0	X	0	0	0	0				0	0	0	
ALUM		70	0	0	0	0	0	0			0	X	0	0	0	0	0
ALUMINUM ACETATE		180	0		0									0	0	0	
ALUMINUM ACETATE		120	0	0	0						0			0	0	0	
ALUMINUM AMMONIUM SULFATE		120		0							0						0
ALUMINUM CHLORIDE	5%	130	0		0						X	0	0	X	0	0	
ALUMINUM CHLORIDE		70	0	0	0	0	0	0	0		0	X	0	0	X	0	0
ALUMINUM CHLORIDE	100%	120		0							0			0			0
ALUMINUM FLUORIDE	5%	70	0	0	0						0	X	0	0	X	0	0
ALUMINUM HYDROXIDE		70	0	0	0			0			0			0	0	0	0
ALUMINUM NITRATE		150	0		0									0			0
ALUMINUM NITRATE		70	0	0	0									0	0	0	0
ALUMINUM PHOSPHATE		250	0								0	0	0	0	X	0	0
ALUMINUM PHOSPHATE		120	0	0		0					0	0	0	0	X	0	0
ALUMINUM SULFATE	10%	150			0									0	0	0	0
AMINES			0	X	0	X	X			0	0	0	0	0	0	0	0
AMINO ACID		150	0		0									0	0		0
AMINOETHANOLAMINE		250	0		0									0	0		0
AMMONIA ANHYDROUS, LIQUID			X	0	0	X	X			0				0	0	0	0
AMMONIA BICARBONATE		120	0	0	0			0			0		0	0	0	0	0
AMMONIA BROMIDE	10%	70						0	0				0				0
AMMONIA CARBONATE	10%	120	0	0	0			0	0					0	0	0	0
AMMONIA CHLORIDE	10%	70	0	0	0		X	0	0		0	0	0		0	0	0
AMMONIA FLUORIDE	10%	70		0							0				0	0	0
AMMONIA GAS		100	0	0	0		0	0	X	0	0	X	0				
AMMONIA GAS WET		100	X	0	X		0	0	X	X	0	0	0				
AMMONIA GAS COLD			100	0	70		70							0	0	0	0
AMMONIA GAS DRY			100	0	70		70			300					0	0	0
AMMONIA GAS HOT					70					300					0	0	
AMMONIA HYDROXIDE	30%	100	0	0	0	0			0	X	0		0	0	0	0	0

*The Premier Source for Filtration and Separation Products*



# MATERIALS SELECTION GUIDE

CHEMICALS	CONCENTRATE	TEMP deg F	MEDIA								CORES				VESSELS			
			COTTON	POLYPROPYLENE	RAYON	POLYESTER	NYLON	ACRYLIC	MODACRYLIC	FIBERGLASS	POLYPROPYLENE	TIN	304 S.S.	316 S.S.	CARBON STEEL	304 S.S.	316 S.S.	POLYPROPYLENE
AMMONIA HYPOSULFITE	10%	150																
AMMONIA NITRATE	5%	200					X											
AMMONIA NITRATE		100	0	0	0		X											
AMMONIA OXALATE	10%	120		0														
AMMONIA PHOSPHATE		120		0														
AMMONIA SULFATE	5%	70	0	0		0												
AMMONIA THIOCYANATE		70	0	0		0												
AMMONIUM ACETATE				0	0		0											
AMMONIUM DICHROMATE				0	0													
AMMONIUM PERSULFATE			0	0	0		0											
AMMONIUM PHOSPHATE MONOBASIC				0	0	0												
AMMONIUM PHOSPHATE TRIBASIC				0	0	0												
AMMONIUM SULFIDE				0	0	X												
AMMONIUM SULFITE				0	0	0												
AMYL ACETATE		70	0	0	0	0	0	0	0	X	0	0	0	0	0	0	0	X
AMYL ALCOHOL		70	0	0	0			0			0	0	0	0	0	0	0	0
AMYL AMINE																		
AMYL BORATE																		
AMYL CHLORIDE																		
ANILINE		70	0	0		0	0	0			0	0	0	0	0	0	0	0
ANILINE DYES																		
ANILINE HYDROCHLORIDE	5%																	
ANIMAL FATS		120	0	0	0			0			0	X	0	0	X	0	0	
ANTHRAQUINONE																		
ANTIFREEZE (ALCOHOL BASE)																		
ANTIFREEZE (GLYCOL BASE)																		
AQUA REGIA		70	X	0			X		0	0	0	X	X	X	X	X	X	
ARGON																		
AROMATIC HYDROCARBONS																		
ARSENIC ACID		150	X				X			0		X	0	0	X	0	0	
ARSENIC ACID		70	X	0			X	0	0	0	0	X	0	0	X	0	0	0
ASPHALT		70	0	0	0						X	0	0	0				
ATHYL BUTYL KETONE																		
AVIATION FUEL		200	0		0		0	0	0	0	X	0	0	0	0	0	0	X
B. HYDROXIDE SUBCARBONATE		250	0		0			0					0	0	0	0	0	
BANANA OIL		70	0	0	0	0	0	0	0		X	0	0	0	0	0	0	X
BARIUM CARBONATE		200	0		0	0	0	0	0									0
BARIUM CARBONATE		70	0	0	0	0	0	0	0					0	0	0	0	X
BARIUM CYANIDE																		
BARIUM NITRATE																		
BARIUM SULFATE																		
BARIUM SULFIDE		120		0					0		0	X		0	0	0	0	
BEER		200	0									X	0	0	X	0	0	
BEER		120	0	0							0	X	0	0	X	0	0	
BEET SUGAR LIQUOR		250	0		0								0	0	X	0	0	
BEET SUGAR LIQUOR		120	0	0	0								0	0	X	0	0	
BENSYLAMINE		200							0									
BENSYLAMINE		120		0					0				0				0	
BENZALDEHYDE									0				0	0	0	0	0	
BENZENE		250	0	X	0		0	0		0	X	0	0	0	0	0	0	
BENZIN		70	0	0	0				0		0	0			0	0	0	
BENZOIC ACID	10%	200	0		0										X	0	0	
BENZOIC ACID	3%	120	0	0	0			0			0				X	0	0	
BENZOYL CHLORIDE																		
BENZYL ACETATE																		

The Premier Source for Filtration and Separation Products



# MATERIALS SELECTION GUIDE

CHEMICALS	CONCENTRATE	TEMP deg F	MEDIA							CORES				VESSELS				
			COTTON	POLYPROPYLENE	RAYON	POLYESTER	NYLON	ACRYLIC	MODACRYLIC	FIBERGLASS	POLYPROPYLENE	TIN	304 S.S.	316 S.S.	CARBON STEEL	304 S.S.	316 S.S.	POLYPROPYLENE
BENZYL ALCOHOL																		
BENZYL BENZOATE																		
BENZYL DICHLORIDE																		
BERYLLIUM CARBONATE		120		0				0		0								
BISMUTH HYDROXIDE		250	0		0			0										
BISMUTH HYDROXIDE		120	0	0	0			0		0								
BISMUTH SUBCARBONATE		120	0	0	0			0		0	0	0	0	0	0	0	0	0
BLACK LIQUOR		120	X	0	X			X		X	X	0	0		X	0		
BLEACH SOLUTIONS																		
BORAX		250	0		0					0	0	0	0		0	0	0	0
BORAX		120	0	0	0			0		0	0	0	0	0	0	0	0	0
BORIC ACID	10%	250	0		0			0		0	X	0		X	0	0	0	0
BORIC ACID		120	0	0	0			0		0	X	0		X	0	0	0	0
BRASS CYANIDE		120	0	0					0	0	0				0	0		
BROMINE ANHYDROUS																		
BROMINE (DRY)		70	0	0	0						X	X	X	X	X	X	X	X
BROMINE (WET)		70	X	0	X			X			X	X	X	X	X	X	X	X
BROMINE TRIFLUORIDE																		
BROMO BENZOIC ACID		120	0	0	0			0		0	0	0	0		0	0		
BROMOBENZENE																		
BROMOCHLOROMETHANE																		
BROMOTOLUENE																		
BRONZE CYANIDE		70	0	0	0					0				0				
BUNKER C		200	0		0			0			0	0		0	0	0		
BUNKER C		70	0	0	0			0		0	0	0		0	0	0		
BUTADIENE		120		0							0	0	0	0	0	0	0	0
BUTANE		70	0	0	0			0	0	0	0	X	0	0	0	0	0	0
BUTANOIC ACID		200	0					0		0		0		0	0	0	0	0
BUTY AMINE																		
BUTYL ACETATE		200	0		0			0	0	0	0	X	0	0		0	0	0
BUTYL ACETATE		70	0	0	0			0	0	0	0	X	0	0	0	0	0	0
BUTYL ACRYLATE																		
BUTYL ALCOHOL		200	0		0	0	0	0	0	0	0	0	0	0	0	0	0	0
BUTYL BENZOATE																		
BUTYL BROMIDE																		
BUTYL BUTYRATE																		
BUTYL CELLOSOLVE		70	0	0	0			0		0	0	0	0		0	0	0	0
BUTYL CELLOSOLVE CHLORIDE		70	0					0			0	0		0	0	0	0	0
BUTYL CELLOSOLVE STERATE		200	0		0			0				X		0	X	0		
BUTYL CELLOSOLVE STERATE		120	0	0	0			0		0		X		0	X	0		
BUTYL ETHER																		
BUTYL STEARATE																		
BUTYLENE		70	0					0	0	0	X	0	0	0	0		0	
BUTYRIC ACID		70	0	0			X		0		0	0	0				0	
CADIUM CYANIDE		70	0	0	0					0				0	0			
CADIUM FLUOBORATE		70	0	0	0					0			0		X	0		
CALCIUM ACETATE HYDRATE																		
CALCIUM BISULFATE		250			0			0			X		0	X				
CALCIUM BISULFATE		120	0	0	0			0		0	X	0	0	X		0		
CALCIUM BISULFITE																		
CALCIUM CARBONATE		250	0		0			0			X		X	0	0			
CALCIUM CARBONATE		120	0	0	0			0		0	X		X	0	0			
CALCIUM CHLORATE																		
CALCIUM CHLORIDE		200					X	0	0	0	X	X	0	0				
CALCIUM CHLORIDE		120		0		0	X	0	0	0	X	X	0	0				

*The Premier Source for Filtration and Separation Products*

**MATRIX**  
SEPARATIONS

PHONE 423.267.2397 FAX 423.267.0298



# MATERIALS SELECTION GUIDE

CHEMICALS	CONCENTRATE	TEMP deg F	MEDIA								CORES				VESSELS			
			COTTON	POLYPROPYLENE	RAYON	POLYESTER	NYLON	ACRYLIC	MODACRYLIC	FIBERGLASS	POLYPROPYLENE	TIN	304 S.S.	316 S.S.	CARBON STEEL	304 S.S.	316 S.S.	POLYPROPYLENE
CALCIUM HYDROSULFIDE																		
CALCIUM HYDROXIDE	5%	100	O	O	X		O	O	O	X	O	X		O			O	
CALCIUM HYDROXIDE	100%	100	O	O	O			O			O			O	O	O	O	
CALCIUM HYDROXIDE																		
CALCIUM HYPOCHLORIDE		120	X	O	X		X	X	O	X	O	X	X	X	X	X	X	X
CALCIUM NITRATE	10%	120		O							O		O	O	O	O	O	
CALCIUM OXALATE		120		O							O							
CALCIUM OXIDE																		
CALCIUM SILICATE																		
CALCIUM SULFATE		120	O	O	O						O			O				
CALCIUM SULFATE		70	O	O	O						O		O	O	O	O		
CALCIUM SULFIDE																		
CALCIUM SULFITE																		
CANE SUGARS LIQUORS		200	O		O		O	O	O		X	O	O	O	O	O	O	
CANE SUGARS LIQUORS		120	O	O	O	O	O	O	O		O	X	O	O	O	O	O	
CAPROLACTUM																		
CAPROLACTUM CARBOLIC ACID		70	O	O	O		X	X	X	O	O	X	X	O				
CAPRYL ALCOHOL																		
CAPRYLIC ACID																		
CARBOLIC ACID		200	O		O		X	X	X	O		X	X	O				
CARBON BISULFIDE		70	O	X							X	O	O	O			O	
CARBON DIOXIDE (DRY)		200	O		O						O	O	O	O	O	O	O	
CARBON DIOXIDE (DRY)		100	O	O	O		O	O	O	O	O	O	O	O	O	O	O	
CARBON DISULFIDE		70	O	X							X	O	O	O	O		O	
CARBON MONOXIDE											X	O	O	O	O	O	O	
CARBON TETRACHLORIDE		200	O		O		O	O	O	O	O			O	O	O	O	
CARBON TETRACHLORIDE		100	O	O	O		O	O	O	O	O	O	O	O	O	O	O	
CARBONATE CHLORIDE	5%	210	O		O						X	X		X			O	
CARBONATE CHLORIDE		120	O	O	O						O	X	X	O	X	O	O	
CARBONATE HYDROXIDE		250	O		O						X	O	O	X	O	O		
CARBONATE HYDROXIDE		120	O	O	O						O	X	O	O	X	O	O	
CARBONATED CARBONIC ACID		100	O	O	O		O	O	O		O	X	O	O	X	O	O	
CARBONATED WATER		100	O	O	O		O	O	O		O	X	O	O	O	O	O	
CASTOR OIL		250	O		O						X	O	O					
CASTOR OIL		120	O	O	O						O	X	O	O				
CAUSTIC POTASH		200					O	O						O	O		O	O
CAUSTIC POTASH		120		O			O	O						O	O	O	O	O
CAUSTIC SODA		200					O					O	O			O	O	
CAUSTIC SODA		120		O			O				O	O	O		O	O	O	
CELLOSOLVE		70	O	O	O						O				O	O	O	
CELLULOSE		120	O	O							O					O	O	
CELLULOSE ACETATE																		
CESIUM CARBONATE		120		O							O							
CETYL ALCOHOL		120	O	O	O						O						O	
CHINA WOOD OIL		200																
CHLORACETIC ACID		70	X	O	X						X	X	X	X	O	O		
CHLORINATED LIME 35% BLEACH																		
CHLORINATED WATER																		
CHLORINE DIOXIDE																		
CHLORINE GAS (DRY)		70	X	X	X		X	X	O	O	X	O	O	O	O	O	O	O
CHLORINE GAS (WET)		70	X	X	X						X	X	X	X	X	X	X	O
CHLORINE, ANHYDROUS LIQUID																		
CHLOROACETIC ACID																		
CHLOROBENZENE		200	O		O		O	O	O	O				O	O		O	O
CHLOROBENZENE		80	O	O	O	O	O	O	O	O	O	O	O	O	O	O	O	O

The Premier Source for Filtration and Separation Products



## MATERIALS SELECTION GUIDE

CHEMICALS	CONCENTRATE	TEMP deg F	MEDIA								CORES				VESSELS			
			COTTON	POLYPROPYLENE	RAYON	POLYESTER	NYLON	ACRYLIC	MODACRYLIC	FIBERGLASS	POLYPROPYLENE	TIN	304 S.S.	316 S.S.	CARBON STEEL	304 S.S.	316 S.S.	POLYPROPYLENE
CHLOROFORM (DRY)		200	0		0				0	0	0							
CHLOROFORM (DRY)		70	0	0	0	0			0	0	0	0	0	0	0	0	0	0
CHLOROSULFONIC ACID			X	X	X				0			X	X	X	0	X	X	X
CHLOROTHENE																		
CHLOROTRIFLUOROETHYLENE																		
CHROMIC ACID		250	X		X			X			0	X	X		0	0		0
CHROMIC ACID		80	X	0	X			X	0	0	0	X	X	0	0	0	0	0
CHROMIC ACID OVER 25%																		
CHROMIC ACID TO 25%																		
CIDAR		250	0						0			X	0	0	0	0	0	0
CIDAR		120	0	0	0				0			0	0	0	0	0	0	0
CITIC OILS																		
CITRIC ACID	5%	120	0		0				0	0	0	0	X	0	0	X	0	0
CITRIC ACID	15%	120	0	0	0							0	X	0	0	X	0	0
CLOROX		120	0	0								0						
COBALT CHLORIDE																		
COCONUT OIL									0						0			0
COD LIVER OIL		70	0	X	0				0			X		0	0	0	0	0
COFFEE		250	0	X	0				0			X		0	0	X	0	0
COFFEE EXTRACT		200	0	X	0				0			X		0	0	X	0	0
COLA SYRUP		70	0	0	0				0			0		0	0		0	0
COLD CREAM		200						X	0	0	0	0	X	0	0	X	0	0
COLD CREAM		120	0	0	0				0			0		0	0		0	
COPPER ACETATE																		
COPPER AMMONIA HYDROXIDE	5%	120	0	0	0				0			0					0	0
COPPER AMMONIUM ACETATE		120	0	0	0				0			0		0	0		0	
COPPER AMMONIUM CHLORIDE				0					0			0	0	X	X	X		
COPPER AMMONIUM NITRATE		120	0	0	0				0			0		0	0			0
COPPER AMMONIUM SULFATE		120	0	0	0	0		X	0	0	0	0	X	0	0	X	0	0
COPPER CHLORIDE																		
COPPER CYANIDE																		
COPPER CYANIDE		70	0	0	0							0	0	0	0	0	0	0
COPPER FLUOBORATE		70							0					0	0		0	0
COPPER FLUOROBORATE																		
COPPER NITRATE HEXAHYDRATE																		
COPPER SULFATE																		
COPPER SULFIDE																		
CORN OIL		200	0		0			0	0	0			0	0	0	0	0	0
CORN OIL		100	0	0	0			0	0	0		0	0	0	0	0	0	0
COTTON SEED OIL		200	0		0			0	0	0			0	0	0	0	0	0
COTTON SEED OIL		100	0	0	0			0	0	0		0	0	0	0	0	0	0
CREOSOL		190	0		0				0						0			
CREOSOL		80	0		0				0	0	0		0		0			
CREOSOTE		210	0		0				0				0		0	0	0	0
CREOSOTE		80	0	X	0				0	0		X	0	0		0	0	0
CRESYLIC ACID		190	0		0				0				X	0	0	X	0	0
CRESYLIC ACID		80	0	0	0				0	0	0		0	0	0	X	0	0
CUMEME (ISOPROPYLBENZENE)																		
CUTTING OIL (WATER SOLUBALE)			0	0	0	0	0				0					0	0	0
CYCLOHEXANE		70	0	X	0				0			X	0	0	0	0	0	0
CYCLOHEXANONE		70	0		0				0							0		0
CYCLOPENTANE																		
CYLCLOHEXANOL		120		0								0						
DDT SOLUTION		120	0	0	0				0			0	X					
DECYT ALCOHOL (DECANOL)																		

*The Premier Source for Filtration and Separation Products*



# MATERIALS SELECTION GUIDE

CHEMICALS	CONCENTRATE	TEMP deg F	MEDIA								CORES				VESSELS			
			COTTON	POLYPROPYLENE	RAYON	POLYESTER	NYLON	ACRYLIC	MODACRYLIC	FIBERGLASS	POLYPROPYLENE	TIN	304 S.S.	316 S.S.	CARBON STEEL	304 S.S.	316 S.S.	POLYPROPYLENE
DENATURED ALCOHOL																		
DEXTROSE		250	0		0			0			0	0	0	0	0	0	0	
DEXTROSE		120	0	0	0			0			0	0	0	0	0	0	0	
DIACETONE ALCOHOL		200	0	0	0			0			0	0	0	0	0	0	0	
DIACETONE ALCOHOL		70	0	0	0			0			0	0	0	0	0	0	0	
DIBENZYL ETHER																		
DIBUTYL AMINE																		
DIBUTYL PHTHALATE		70	0	0	0			0			0	0	0	0	0	0	0	
DIBUTYL PHTHALATE (DBP)																		
DICHLORETHENE																		
DICHLOROACETIC ACID																		
DICHLOROBENZENE																		
DICHLOROETHYL ETHER																		
DICHLOROETHYLENE		200	0		0			0	0	0				0				
DICHLOROETHYLENE		70	0	0	0			0	0	0	0			0				
DICHLOROETHYLENE																		
DICHOROETHANE		70	0	X	0			0			X	0	0			0	0	
DICYCLOHEXYLAMINE																		
DIELECTRIC		200	0		0			0								0	0	0
DIESEL FUEL		200	0		0			0	0	0	0		0	0	0	0	0	
DIESEL FUEL		120	0	0	0			0	0	0	0	0	0	0	0	0	0	
DIETHANOL AMINE		70	0		0			0			0			0				
DIETHYL AMINE																		
DIETHYL BENZENE																		
DIETHYL CARBONATE		120		0				0			0							
DIETHYL ETHER																		
DIETHYL PHTHALATE																		
DIETHYL SEBECATE																		
DIETHYLENE GLYCOL		70	0		0			0			0	0	0	0	0	0	0	
DIETHYLENE TRIAMINE																		
DILSODECYL ADIPATE (DIDA)																		
DIMETHY FORMAMIDE		200	0		0	0	0	X	X	0				0				
DIMETHY FORMAMIDE		70	0	0	0	0	0	X	X	0	0	0	0	0	0	0	0	0
DIMETHYL ETHER																		
DIMETHYL FORMAMIDE (DMF)																		
DIMETHYL PHTHALATE																		
DIMETHYL SULFOXIDE																		
DIMETHYLANILINE																		
DINITROTOUENE (DNT)																		
DIOCTYL SEBECATE																		
DIPHENYL OXIDE		70	0	0	0			0			0	0	0	0	0	0	0	0
DIPHENYL OXIDES (PHENYL ETHER)																		
DIPROPYL KETONE																		
DIPROPYL GLYCOL																		
DIPROPYLAMINE																		
DITHYLENE ETHER (DIOXANE)																		
DLISOBUTYL KETONE																		
DLISOBUTYLENE																		
DLISODECYL PHTHALATE (DIDP)																		
DLISOCTYL ADIPATE (DIOA)																		
DLISOCTYL PHTHALATE (DIOP)																		
DLISOCTYL SEBECATE (DIOS)																		
DLISOPROPYL BENZENE																		
DLISOPROPYL KETONE																		
DODECYL BENZENE																		

The Premier Source for Filtration and Separation Products



# MATERIALS SELECTION GUIDE

CHEMICALS	CONCENTRATE	TEMP deg F	MEDIA								CORES				VESSELS			
			COTTON	POLYPROPYLENE	RAYON	POLYESTER	NYLON	ACRYLIC	MODACRYLIC	FIBERGLASS	POLYPROPYLENE	TIN	304 S.S.	316 S.S.	CARBON STEEL	304 S.S.	316 S.S.	POLYPROPYLENE
DOWTHERM		250								0								
DOWTHERM		70	0	0	0				0		0		0	0	0	0	0	0
DYES		120	0	0							0	0			0			
EPICHLOROHYDRIN		70	0	0	0						0	0						
ETHANE																		
ETHANOL		200	0		0	0	0	0	0	0		0	0	0	0	0	0	
ETHANOL		120	0	0	0	0	0	0	0	0	0	0	0	0	0	0	0	0
ETHANOLAMINE		70	0	0							0	0	0	0	0	0	0	0
ETHER		200	0				0	0	0	0		0	0	0	0	0	0	0
ETHER		120	0	0			0	0	0	0	0	0	0	0	0	0	0	0
ETHYL ACETATE		250	0					0		0		0	0	0	0	0	0	0
ETHYL ACETATE		80	0	0	0	0	0	0	0	0	0	0	0	0	0	0	0	0
ETHYL ACRYLATE																		
ETHYL ALCOHOL		250	0		0			0			0	0	0	0	0	0	0	
ETHYL ALCOHOL		120	0	0	0			0			0	0	0	0	0	0	0	
ETHYL BENZENE																		
ETHYL BENZOATE		120		0				0			0							
ETHYL BROMIDE (BROMOETHANE)																		
ETHYL BUTYL ACETATE																		
ETHYL BUTYL ALCOHOL																		
ETHYL BUTYRALDEHYDE																		
ETHYL BUTYRATE																		
ETHYL CAPRYLATE																		
ETHYL CELLULOSE		70		0				0			0	X	0	0	0	0	0	
ETHYL CHLORIDE (DRY)		70	0	X	0			0			X	0	0	0	0	0	0	X
ETHYL CYANIDE (PROPIONTITE)																		
ETHYL ETHER		200	0		0			0	0	0		0	0	0	0	0	0	
ETHYL ETHER		120	0	0	0			0	0	0	0	0	0	0	0	0	0	0
ETHYL OXALATE																		
ETHYL PROPIONATE																		
ETHYL SULFATE																		
ETHYLCELLOSOLVE																		
ETHYLENE (ETHANE)																		
ETHYLENE CHLOROHYDRIN																		
ETHYLENE DIAMINE		70	0	0	0			0	0		0	0	0	0	0	0	0	0
ETHYLENE DIBROMIDE																		
ETHYLENE DICHLORIDE		120	0	0	0			0			0	X	0		0	0	0	
ETHYLENE GLYCOL		200	0		0			0	0	0		0	0	0	0	0	0	
ETHYLENE GLYCOL		70	0	0	0	0	0	0	0	0	0	0	0	0	0	0	0	0
ETHYLENE GLYCOL MONOMETHYL ETHER																		
ETHYLENE GLYCOL MONOBUTYLETHER																		
ETHYLENE OXIDE		50	0	X	0			0	X	0	X	0	0	0	0	0	0	0
ETHYLENE TRICHLORIDE																		
FATTY ACIDS		100	0	0	0			0	0	0	0	X	0	0	X	0	0	
FERRIC CHLORIC																		
FERRIC CHLORIDE	1%	200	X		X	0		0	0		X	X	X	X	X	X		
FERRIC CHLORIDE		70	X	0	X	0	0	0	0	0	X	X	X	X	X	X	0	
FERRIC CHLORIDE	100%	200	X		X	0			0		X	X	X	X	X	X		
FERRIC CHLORIDE		70	X	0	X	0	0		0	0	X	X	X	X	X	X	0	
FERRIC CYANIDE		120		0							0				X			
FERRIC HYDROXIDE		120	0	0	0			0			0				X	0	0	
FERRIC NITRATE	5%																	
FERRIC NITRATES		70		0		0		0			0		0				0	
FERRIC SULFATE	5%	70	0	0	0	0	0	0			0	X	0	0	0	0	0	0
FERROUS CHLORIDE		70	0	0	0	0	0	0			0				X		0	0

The Premier Source for Filtration and Separation Products



# MATERIALS SELECTION GUIDE

CHEMICALS	CONCENTRATE	TEMP deg F	MEDIA								CORES				VESSELS			
			COTTON	POLYPROPYLENE	RAYON	POLYESTER	NYLON	ACRYLIC	MODACRYLIC	FIBERGLASS	POLYPROPYLENE	TIN	304 S.S.	316 S.S.	CARBON STEEL	304 S.S.	316 S.S.	POLYPROPYLENE
FERROUS SULFATE																		
FISH OILS		70	0	0	0			0		0	0	0	0	0	0	0	0	
FLUOBORIC ACID		120	X	0	X			X		0		0	0	0	0	0	0	
FLUORINE (GAS)																		
FLUOROBENZENE																		
FLUOROLUBE (FLUROCARBON OILS)																		
FLUOSILICIC ACID		70	0	0	0					0	X	X		X		0		
FORMALDEHYDE	10%	200							0	0	X	0	0	X	0	0		
FORMALDEHYDE		70	0	0	0	0	0	0	0	0	0	0	0	X	0	0		
FORMALIN (FORMALDEHYDE)	40%	70	0	0	0			0		0	X	0	0	X	0	0		
FORMAMIDE																		
FORMIC ACID	3%																	
FORMIC ACID	10%																	
FORMIC ACID (CONC)		100	0	0	X		X	X	0	0	X			X	0	0		
FORMIC ACID (DILUTE)		200			X	0	X		0	0	X			X				
FORMIC ACID (DILUTE)		100	0	0	X	0	X	0	0	0	X			X	0	0		
FREON 11		200	0		0			0	0	0	0	0	0	0	0	0		
FREON 113																		
FREON 114																		
FREON 114B2																		
FREON 115																		
FREON 12		100	0		0		0	0	0	0	0	0	0	0	0	0		
FREON 13																		
FREON 13B1																		
FREON 14																		
FREON 21																		
FREON 22		200	0		0			0	0	0	0	0	0	0	0	0		
FREON 22		100	0	X	0		0	0	0	X	0	0	0	0	0	0		
FRUIT JUICES		70	0	0	0			0		0				X	0	0		
FUEL OILS		200	0		0	0	0	0	0	0	0	0	0	0	0	0		
FUEL OILS		70	0	0	0	0	0	0	0	0	0	0	0	0	0	0		
FUMING		100	X	X	X	X	X	X	X	0	X	X	0	0	X	0	0	
FURAN (FURFURAN)																		
FURFURAL		70	0	0	0			0		0	0	0	0	0	0	0		
FURFURYL ALCOHOL																		
GAS AVIATION																		
GAS-NATURAL		70	0	0	0			0		0	0	0	0	0	0	0	0	
GASOLINE (PETROL)																		
GASOLINE (UNLEADED)																		
GASOLINE AVIATION		250	0	X	0		0	0	0	X	0	0	0	0	0	0	X	
GASOLINE-MOTOR		250	0	X	0		0	0	0	X	0	0	0	0	0	0	X	
GASOLINE-SOUR		70	0	X	0		0	0	0	X	X	0	0	0	0	0	X	
GELATIN		70	0	0	0			0		0	X	0	0	0	0	0		
GLUCOSE		70	0	0						0		0	0	0	0	0		
GLUE		250	0		0			0		0	0	0	0	0	0	0		
GLUE		120	0	0	0			0		0	0	0	0	0	0	0		
GLYCERIN		70	0	0						0	0	0	0	0	0	0		
GLYCEROL		70	0	0						0	0	0	0	0	0	0		
GLYCOL		200	0		0	0		0	0	0	0	0	0	0	0	0		
GLYCOL		70	0	0	0	0	0	0	0	0	0	0	0	0	0	0		
GLYCOL MONOETHER		70	0	0	0			0		0	0	0	0	0	0	0		
GLYCOLIC ACID																		
GLYCOLS																		
GOLD CYANIDE																		
GOLD CYANIDE		120	0	0	0		0			0	0	0	0	0	0	0		

The Premier Source for Filtration and Separation Products

# MATERIALS SELECTION GUIDE

CHEMICALS	CONCENTRATE	TEMP deg F	MEDIA								CORES				VESSELS			
			COTTON	POLYPROPYLENE	RAYON	POLYESTER	NYLON	ACRYLIC	MODACRYLIC	FIBERGLASS	POLYPROPYLENE	TIN	304 S.S.	316 S.S.	CARBON STEEL	304 S.S.	316 S.S.	POLYPROPYLENE
GOLD FLUOBORATE		70	0	0					0			0						
GREASE		250	0		0				0			0	0	0	0	0	0	
GREASE		120	0	0	0				0			0	0	0	0	0	0	
GREEN LIQUOR		70	X	0	X			X	X	X		0	X	X	0	X	X	0
GUM ARABIC		70	0		0				0				0					0
HELIUM		200	0		0	0		0	0	0		0	0	0	0	0	0	
HELIUM		120	0	0	0	0		0	0	0		0	0	0	0	0	0	
HEPTANAL																		
HEPTANE																		
HEXANAL																		
HEXANE		250	0		0				0			0	0	0	0	0	0	
HEXANE		70	0	0	0				0			0	0	0	0	0	0	
HEXYL ALCOHOL																		
HONEY		200	0		0				0				0	0		0	0	
HONEY		120	0	0	0				0				0	0		0	0	
HYDRAULIC OIL (PETROLEUM BASE)																		
HYDRAULIC OIL (PHOS. ESTER)		70	0	0	0				0			0	0	0	0	0	0	
HYDRAZINE		250							0					0			0	
HYDRAZINE (DIAMINE)																		
HYDROBROMIC ACID	10%	120	X	0	X					0	0	X	X	X	X	X	X	0
HYDROBROMIC ACID		70	X	0	X	0		X		0	0	0	X	X	X	X	X	0
HYDROCHLORIC ACID	30%	200	X		X			X		0	0		X	X	X	X	X	
HYDROCHLORIC ACID		120	X	0	X			X	0	0		0	X	X	X	X	X	0
HYDROCHLORIC ACID	5%																	
HYDROCYANIC ACIDE																		
HYDROCYANIMIC ACID		70	0	0	X				X			0	X	0	0	X	0	0
HYDROFLUORIC ACID	10%	120		0				X	0	0	X	0	X	X	X	X	X	0
HYDROFLUORIC ACID		70	0	0	0	0		X	0	0	X	0	X	X	X	X	X	0
HYDROFLUORIC ACID	50%	70	X	0	X			X	0	0	X	0	X	X	X	X	X	0
HYDROFLUORIC ACID (CONC) COLD																		
HYDROFLUOSILICIC		120	X	0	0						0	X	X		X	X	0	
HYDROGEN GAS		250	0		0					0		0		0	0	0	0	
HYDROGEN GAS		120	0	0	0				0		0	0	0	0	0	0	0	0
HYDROGEN PEROXIDE	3%																	
HYDROGEN PEROXIDE	5%	100	0	0	0			X	0	0	0	0	X	0	0	X	0	0
HYDROGEN PEROXIDE	30%	100	X	0	X			X	0	0	0	0	X	0	0	X	0	0
HYDROGEN PEROXIDE	90%																	
HYDROGEN SULFIDE (DRY)		70	0	0	0							0	0	0	0	0	0	0
HYDROGEN SULFIDE (WET)		70	0	0	0							0	X	0	0	X	0	0
HYDROLIC OIL (PETRO)		250	0		0				0				0	0	0	0	0	0
HYDROLIC OIL (PETRO)		70	0	0	0				0				0	0	0	0	0	0
HYDROQUINONE		70	0	0	0				0				0	0	0		0	0
HYDROXYACETIC ACID	10%																	
HYPOCHLOROUS ACID		120	0	0	0							0	X	X	X	X	X	X
IDOFORM																		
INSULTATING OIL		70	0		0				0				0	0	0	0	0	0
IODINE		70		0								0	X			X	0	0
IRON CHLORIDE		120	X	0	X					0			X	0		X		
IRON SULFATE		120	X	0	X					0				0	0		0	
ISOBUTYL ALCOHOL																		
ISOBUTYL AMINE																		
ISOBUTYL CHLORIDE																		
ISOCTANE (TRIMETHYLPENTANE)																		
ISOPENTANE																		
ISOPROPANOL		200	0		0				0				0	0	0	0	0	0

*The Premier Source for Filtration and Separation Products*



# MATERIALS SELECTION GUIDE

CHEMICALS	CONCENTRATE	TEMP deg F	MEDIA								CORES				VESSELS			
			COTTON	POLYPROPYLENE	RAYON	POLYESTER	NYLON	ACRYLIC	MODACRYLIC	FIBERGLASS	POLYPROPYLENE	TIN	304 S.S.	316 S.S.	CARBON STEEL	304 S.S.	316 S.S.	POLYPROPYLENE
ISOPROPANOL		70	0	0	0	0		0		0			0	0	0	0	0	0
ISOPROPYL ACETATE		200	0					0		0								0
ISOPROPYL ALCOHOL		200	0		0			0		0			0	0	0	0	0	
ISOPROPYL ALCOHOL		70	0	0	0	0				0			0	0	0	0	0	0
ISOPROPYL CHLORIDE																		
ISOPROPYL ETHER		200	0		0	0	0	0		0		0	0	0	0	0	0	
JET FUELS (JP1 TO JP6)																		
KEROSENE		70	0	0	0	0	0	0		0	0	0	0	0	0	0	0	0
KETCHUP		70	0	0	0					0	X	0	0	X	0	0	0	
LACQUER SOLVENT		80	0	0	0			0		0	0	0	0	0	0	0	0	
LACTIC ACID	3%	200						0	0	0								
LACTIC ACID		70	0	0	0	0	0	0	0	0	X	X	X	X	X	X	X	
LARD OIL		200	0		0			0	0	0		0	0	0	X	0	0	
LARD OIL		80	0	0	0			0	0	0		0	0	0	X	0	0	
LATEX (NATURAL)		70	0	0	0			0		0	0	0	0	0	0	0	0	
LEAD ACETATE		200	0		0									X	0	0	0	
LEAD ACETATE		120	0	0	0					0		0	0	X	0	0	0	
LEAD ALKALI		120		0			0		0	0		0	0	0		0	0	
LEAD ALKALI FLUOBORATE		100	X		X				0			0	0		0	0	0	
LEAD CHLORIDE																		
LEAD NITRATE																		
LEAD SULFATE																		
LIME BLEACH																		
LIME-SULFUR		70	0	0	0					0			0		0	0	0	
LINOLEIC ACID		100	0	0	0		X	0	0	0	X	0	0	X	0	0	0	
LINSEED OIL		200	0		0			0	0	0		0	0	0		0	0	
LINSEED OIL		100	0	0	0	0	0	0	0	0	0	0	0	0	0	0	0	
LITHIUM BROMIDE		200	0		0								0	0		0	0	
LITHIUM BROMIDE		70	0	0	0					0	0		0	0		0	0	
LITHIUM CARBONATE		250	0		0			0										
LITHIUM CARBONATE		70	0	0	0			0		0								
LITHIUM CHLORIDE		200	0		0						0	0	0	0	0	0	0	
LITHIUM CHLORIDE		70	0	0	0					0	0	0	0	0	0	0	0	
LITHIUM HYDROXIDE		100	0	0	0		0		0	0	X	0	0	0	0	0	0	
LUBE OIL		200	0		0			0	0	0		0	0	0	0	0	0	
LUBE OIL		70	0	0	0			0	0	0	0	0	0	0	0	0	0	
LYE		120	X	0	X	X	0	X	0	X	0	X	0	0	0	0	0	
MAGNESIUM CARBONATE																		
MAGNESIUM CHLORIDE		70	0	0	0	0	0	0		0			0	X	0	0	0	
MAGNESIUM HYDROXIDE		70	0	0	0			0		0	0	0	0	0	0	0	0	0
MAGNESIUM NITRATE		100	0	0	0					0							0	
MAGNESIUM OXIDE		250	0		0			0				0	0		0	0	0	
MAGNESIUM OXIDE		120	0	0	0			0		0		0	0		0	0	0	
MAGNESIUM SULFATE		70	0	0	0					0	X	0	0	0	0	0	0	
MALEIC ACID		100	0		0												0	
MAYONNAISE		70	0	0	0					X	0	X	0	0	X	0	0	0
MELAMINE RESIN		70	0	0	0			0		0		X	X		X	X		
MERCURIC CHLORIDE	10	70	0	0	0	0				0	X	X	0	X	X	0		
MERCURIC CYANIDE																		
MERCUROUS NITRATE		70		0						0	0	0	0	0	0	0	0	
MERCURY		70	0	0	0			0		0	0	0	0	0	0	0	0	
METHANE		70	0	0	0			0		0	0	0	0	0	0	0	0	
METHANOL		200	0		0	0	0	0	0	0		0	0	0	0	0	0	
METHANOL		120	0	0	0	0	0	0	0	0	0	0	0	0	0	0	0	
METHYL ACETATE		70		0						0	X	0	0	0	0	0	0	

The Premier Source for Filtration and Separation Products



## MATERIALS SELECTION GUIDE

CHEMICALS	CONCENTRATE	TEMP deg F	MEDIA								CORES			VESSELS				
			COTTON	POLYPROPYLENE	RAYON	POLYESTER	NYLON	ACRYLIC	MODACRYLIC	FIBERGLASS	POLYPROPYLENE	TIN	304 S.S.	316 S.S.	CARBON STEEL	304 S.S.	316 S.S.	POLYPROPYLENE
METHYL ACRYLATE																		
METHYL ALCOHOL		200	0		0	0	0	0	0	0	0	0	0	0	0	0	0	0
METHYL ALCOHOL		120	0	0	0	0	0	0	0	0	0	0	0	0	0	0	0	0
METHYL AMINE																		
METHYL ANILINE																		
METHYL BROMIDE																		
METHYL BUTYL KETONE																		
METHYL BUTYRATE																		
METHYL CELLOSOLVE		70		0	0	0		0			0	0	0	0	0	0	0	0
METHYL CHLORIDE		200	0		0		X	0	0		0	0	0				0	0
METHYL CHLORIDE		120	0	0	0		X	0	0		0	0	0				0	0
METHYL DICHLORIDE																		
METHYL ETHYL KETONE		200	0		0		0	0	0		0	0	0	0	0	0	0	
METHYL ETHYL KETONE		80	0	0	0	0	0	0	0		0	0	0	0	0	0	0	0
METHYL HEXANE																		
METHYL ISOBUTYL KETONE																		
METHYL ISOPROPYL KETONE																		
METHYL METHACRYLATE		120	0	0	0			0			X		0		0			
METHYLENE BROMIDE																		
METHYLENE CHLORIDE		250	0	X	0			0			X	0	0		0	0	0	
METHYLPHENYL ETHER																		
MILK		70	0	0	0			0		X	0	0	0	0	0	0	0	0
MINERAL OIL		200	0		0	0	0	0	0	0	0	0	0	0	0	0	0	0
MINERAL OIL		70	0	0	0	0	0	0	0	0	0	0	0	0	0	0	0	0
MOLASSES		250	0		0			0			0	0	0	0	0	0	0	
MOLASSES		70	0	0	0			0			0	0	0	0	0	0	0	0
MONOBETHYLAMINE																		
MONOCHLOROBENZENE																		
MONOETHANOLAMINE (MEA)		70	0	0							0		0	0	0	0	0	
MURIATIC ACID	5%	70	X	0							0	X	X	X	X	X	X	
MUSTARD		70	0	0	0						0	X	0	0	X	0	0	
NAPHTHA		200	0		0		0	0	0		0	0	0	0	0	0	0	
NAPHTHA		70	0	0	0		0	0	0		0	0	0	0	0	0	0	0
NAPHTHALENE		70	0	0	0	0	0	0	0		0	0	0	0	0	0	0	0
NICKEL BRIGHT CHLORIDE		70	0	0	0						0		0		0	0	0	0
NICKEL CHLORIDE		200					X		0	0	X	X	X	X	X			
NICKEL CHLORIDE		70	0	0	0	0	X	0	0	0	0	X	X	X	X	X	0	
NICKEL DULL CHLORIDE		160	0		0			0			0	0			0	0		
NICKEL DULL FLUOBORATE		170						0				0						
NICKEL HYDROXIDE		250	0		0			0										
NICKEL HYDROXIDE		120	0	0	0			0			0							
NICKEL NITRATE																		
NICKEL SULFATE		70	0	0	0		X	0	0		0	X		0	X	0	0	
NITRIC ACID	10%	200				0	X	0	0	0		X	0	0		X	0	0
NITRIC ACID		70	0	0	0	0	X	0	0	0	0	X	0	0	X	0	0	
NITRIC ACID	20%	200	X			X	X		0	0		X			X		0	
NITRIC ACID	25%																	
NITRIC ACID	35%																	
NITRIC ACID		70	X	0	X	X	X		0	0	0	X	0	0	X	0	0	
NITRIC ACID	50%	200	X		X		X			0		X			X	0	0	
NITRIC ACID	70%																	
NITRIC ACID		70	X	0	X		X		0	0	0	X	0	0	X	0	0	
NITROBENZENE	10%	200	0		0	0	0	0	X				0			0	0	
NITROBENZENE		100	0	0	0	0	0	0	X	0	0	0	0		0	0	0	
NITROBENZENE	100%	200	0		0	0	0		X									

*The Premier Source for Filtration and Separation Products*





# MATERIALS SELECTION GUIDE

CHEMICALS	CONCENTRATE	TEMP deg F	MEDIA								CORES				VESSELS			
			COTTON	POLYPROPYLENE	RAYON	POLYESTER	NYLON	ACRYLIC	MODACRYLIC	FIBERGLASS	POLYPROPYLENE	TIN	304 S.S.	316 S.S.	CARBON STEEL	304 S.S.	316 S.S.	POLYPROPYLENE
NITROBENZENE		100	O	O	O	O	O	O	X									
NITROETHANE																		
NITROGEN		200	O		O	O	O	O	O	O	O	O	O	O	O	O	O	
NITROGEN		70	O	O	O	O	O	O	O	O	O	O	O	O	O	O	O	O
NITROMETHANE																		
NITROPROPANE, 1																		
NITROUS OXIDE		70	O	O	O						O	X			O	O	O	
OCTANE																		
OCTYL ALCOHOL																		
OIL CRUDE		200	O		O	O	O	O	O	O	O	O	O	O	O	O	O	O
OIL CRUDE		70	O	O	O	O	O	O	O	O	O	O	O	O	O	O	O	O
OLEIC ACID	5%	200					X		O	O		X	X	O	X	X	O	
OLEIC ACID		100	O	O	O		X	O	O	O	O	X	X	O	X	X	O	
OLEIC ACID	100%	200	X		X		X		O	O	O	X	X	O	X	X	O	
OLEIC ACID		70	X		X		X	O	O	O	O	X	X	O	X	X	O	
OLEUM		100	X	X	X		X	X	X	O	X	X	O	O	X	O	O	
OLIVE OIL		70	O	O	O						O		O	O	O	O	O	O
OXALIC ACID	5%	200					X		O	O		X	O	O		O	O	
OXALIC ACID		100	O	O	O		X	O	O	O	O	X	O	O		O	O	
OXALIC ACID (WET)	10%	200	O					O				X	O	O	X	O	O	
OXALIC ACID (WET)		70	O	O	O				O		O	X	O	O	X	O	O	
OXYGEN		100		O							O				O	O	O	
OZONE																		
P[ARACHLORO ETHLENE		200	O		O	O	O	O	O	O	O	O	O	O	O	O	O	O
P[ARACHLORO ETHLENE		70	O	O	O	O	O	O	O	O	O	O	O	O	O	O	O	O
PALM OIL		70	O	O	O						O		O	O	X	O	O	
PALMIC ACID		70	O	O							O	O	X	O	O	O	O	
PARACHLORO BENZENE		70	O	X							X	O			O			
PARAFIN		120	O	O							O		O	O	O	O	O	
PARAFORMALDEHYDE																		
PENTANE		200	O		O	O	O	O	O	O	O				O	O	O	
PENTANE		70	O	O	O	O	O	O	O	O	O	O	O	O	O	O	O	
PERCHLORIC ACID																		
PERCHLOROETHYLENE (DRY)		70	O	O	O	O	O	O	O	O	O	O	O	O	O	O	O	
PERCHLOROETHYLENE		200	O		O	O	O	O	O	O		O	O	O	O	O	O	
PETROLATUM COSMOLINE		120	O	O							O		O	O	O	O	O	
PETROLEUM ETHER		200	O		O		O	O	O	O		O	O	O	O	O	O	
PETROLEUM ETHER		70	O	O	O		O	O	O	O	O	O	O	O	O	O	O	
PETROLEUM FORMALDEHYDE RESIN		70	O									O	O	O	O	O	O	
PETROLEUM OIL (REFINED)		200	O		O	O	O	O	O	O		O	O	O	O	O	O	
PETROLEUM OIL (REFINED)		70	O	O	O	O	O	O	O	O	O	O	O	O	O	O	O	
PETROLEUM OIL (SOUR)		200	O		O	O	O	O	O				O	O	X	O	O	
PETROLEUM OIL (SOUR)		70	O	O	O	O	O	O	O		O	O	O	O	X	O	O	
PHENOL		200	O		O		X	X	X	O		X	X	O		O	O	
PHENOL		70	O	O	O		X	X	X	O	O	X	X	O	O	O	O	
PHENYLCARBINOL																		
PHOSPHORIC ACID	1%	200					O	O	O			X	O	O	X	O	O	
PHOSPHORIC ACID		100	O	O	O	O	O	O	O	O	O	X	O	O	X	O	O	
PHOSPHORIC ACID	10%	200				O		O	O			X	O	O	X	O	O	
PHOSPHORIC ACID	20%																	
PHOSPHORIC ACID		70	O	O	O	O	O	O	O	O	O	X	O	O	X	O	O	O
PHOSPHORIC ACID	50%	200	X		X		X		O			X		O	X	O	O	
PHOSPHORIC ACID	80%	200	X		X		X		O					X	X			
PHOSPHORUS OXYCHLORIDE																		
PHOSPHORUS TRICHLORIDE																		

The Premier Source for Filtration and Separation Products

## MATERIALS SELECTION GUIDE

CHEMICALS	CONCENTRATE	TEMP deg F	MEDIA							CORES				VESSELS			
			COTTON	POLYPROPYLENE	RAYON	POLYESTER	NYLON	ACRYLIC	MODACRYLIC	FIBERGLASS	POLYPROPYLENE	TIN	304 S.S.	316 S.S.	CARBON STEEL	304 S.S.	316 S.S.
PHTHALIC ACID		70		0						0	X			X		0	
PICRIC ACID		120	X	0	X			X		0	0	X	0	0	X	0	0
PINE OIL		70	0	0	0	0	0	0		0	0	0	0	0	0	0	0
PLATING SOLUTION CHROME																	
PLATING SOLUTION LEAD																	
PLATING SOLUTIONS CADMIUM																	
PLATING SOLUTIONS-ARSENIC		120	0	0	0					0				0			
POLYSULFIDE		200						0	0			0	0		0	0	
POLYSULFIDE		70	0		0			0	0		0	0	0		0	0	
POLYVINYL ACETATE EMULSION																	
POTASSIUM ACETATE	10%	70	0	0	0					0	X	0	0	X	0	0	0
POTASSIUM BICARBONATE																	
POTASSIUM BISULFATE	10%	120	X		X					0		X	0			X	0
POTASSIUM BISULFATE		70	X	0	X					0	0	X	0			X	0
POTASSIUM BROMIDE		100	0	0									0			0	
POTASSIUM CARBONATE	10%	120	0	0		X				0		0	0	0	0	0	0
POTASSIUM CHLORATE																	
POTASSIUM CHLORIDE	5%	70	0	0	0	0	0	0		0	X	0	0	X	0	0	
POTASSIUM CHROMATE	10%	70		0						0		0	0		0	0	0
POTASSIUM CYANIDE	5%	200	0				0	0			X	0	0	0	0	0	
POTASSIUM CYANIDE		120	0	0			0	0		0	X	0	0	0	0	0	
POTASSIUM DICHROMATE																	
POTASSIUM FERROCYANIDE	10%	70	0	0	0					0		0	0	0	0	0	
POTASSIUM HYDROXIDE	10%	200	0				0	0	0	X	X	0	0		0	0	
POTASSIUM HYDROXIDE		120	0	0			0	0	0	X	0	X	0	0	0	0	
POTASSIUM HYDROXIDE	30%																
POTASSIUM IODIDE																	
POTASSIUM NITRATE		120	X	0	0						0		0	0	0	0	
POTASSIUM NITRITE																	
POTASSIUM PERMANGANATE	5%	120	X	0	X						0		0	0	0	0	
POTASSIUM PHOSPHATE																	
POTASSIUM SILICATE																	
POTASSIUM SULFATE	5%	70	0	0	0					0	X	0	0	0	0	0	
POTASSIUM SULFITE																	
POTASSIUM SULFIDE																	
PROPANE		200	0		0		0	0	0	0		0	0	0	0	0	
PROPANE		100	0	0	0		0	0	0	0	0	0	0	0	0	0	
PROPIONAMIDE		120		0							0						
PROPIONIC ACID		70	0	0	0						0	X	X	0	X	X	0
PROPYL (PROPANOL)																	
PROPYL ACETATE																	
PROPYL ALCOHOL ( 1 PROPANE)																	
PROPYLENE GLYCOL		70	0	0	0			0			0		0	0	0	0	
PROPYLENE OXIDE		70	0	0	0						0						
PYRIDINE		250	0							0			0	0	0	0	
PYROLIDRONE, N-METHYL																	
RAPESEED OIL		120		0													
RUBBER LATEX EMULSIONS																	
SALICYLIC ACID		120		00											X	0	0
SALT WATER		200	0		0	0	0	0	0		X	X	X	X	X	X	
SALT WATER		120	0	0	0	0	0	0	0		0	X	X	X	X	X	
SHELLAC (BLEACHED)		250	0	0	0										0	0	0
SHELLAC (BLEACHED)		120	0	0	0										0	0	0
SHELLAC (ORANGE)		250	0	0	0										0	0	0
SHELLAC (ORANGE)		120	0	0	0										0	0	0

*The Premier Source for Filtration and Separation Products*



# MATERIALS SELECTION GUIDE

CHEMICALS	CONCENTRATE	TEMP deg F	MEDIA								CORES				VESSELS			
			COTTON	POLYPROPYLENE	RAYON	POLYESTER	NYLON	ACRYLIC	MODACRYLIC	FIBERGLASS	POLYPROPYLENE	TIN	304 S.S.	316 S.S.	CARBON STEEL	304 S.S.	316 S.S.	POLYPROPYLENE
SILICONE OILS																		
SILICONE OILS		120		O							O				O	O	O	
SILVER		80	O	O	O						O		O	O	O	O	O	O
SILVER CYANIDE																		
SILVER NITRATE																		
SILVER NITRATE		200							O	O	O		O	O	X	O	O	
SILVER NITRATE		120	O	O	O	O	O	O	O	O	O		O	O	X	O	O	
SOAP		120	O	O	O						O	O	O	O	O	O	O	
SOAP SOLUTIONS																		
SODA ASH		70	O	O	O			O	O	O		O	X	O	O	O	O	
SODIUM ACETATE		70	O	O	O							O	X	O	O	X	O	O
SODIUM ALUMINATE																		
SODIUM BICARBONATE		70	O	O	O						O	O	O	O	O	O	O	
SODIUM BISULFATE		70	X	O	X	O	X	O			O	X	X	O	X	X	O	O
SODIUM BISULFITE		120			O							X		O	X		O	
SODIUM BORATE		70	O	O	O						O	X	O	O	X	O	O	O
SODIUM BROMIDE																		
SODIUM CARBONATE		70	O	O	O	O	O	O	O		O	X	O	O	O	O	O	O
SODIUM CHLORATE		120	X	O	X						O		O	O	X	O	O	O
SODIUM CHLORIDE	10%	200	O		O	O	O	O	O			X	O	O		O	O	
SODIUM CHLORIDE		120	O	O	O	O	O	O	O		O	X	O	O	O	O	O	
SODIUM CHLORITE	2%	120		O							O							
SODIUM CHROMATE																		
SODIUM CYANIDE		200	O		X			O	O				O	O		O	O	
SODIUM CYANIDE		120	O	O	X			O	O		O	O	O	O	O	O	O	
SODIUM DICHROMATE	10%	120	X	O	X						O		X					
SODIUM FLUORIDE	5%	70	O	O	O						O	X	X	O	X	O	O	
SODIUM HYDROXIDE	5%	200	O		X			O	X	O	X	X	O	O	O	O	O	
SODIUM HYDROXIDE		120	O	O	X	O	O	X	O	X	O	X	O	O	O	O	O	O
SODIUM HYDROXIDE	20%	200			X	X	O	X	O	X		X	O	O		O	O	
SODIUM HYDROXIDE		120	O	O	X	X	O	X	O	X	O	X	O	O	O	O	O	O
SODIUM HYDROXIDE	40%	200			X	X	O	X	O	X		O	O			O	O	
SODIUM HYDROXIDE		70	O	O	X	X	O	X	O	X	O	O	O		O	O	O	
SODIUM HYPOCHLORITE	5%	100	X	O	X			O	X		X	O	X	O	O	X	O	O
SODIUM META PHOSPHATE		70	O	O	O						O	X	X	O	O	X	O	O
SODIUM METASILICATE																		
SODIUM NITRATE	5%	70	O	O	O			O	O		O	O	X	O	O	O	O	O
SODIUM PERBORATE	1%	160	O		O						X	O	O	O	O	O	O	
SODIUM PERBORATE		70	O	O	O					O	O	X	O	O	O	O	O	
SODIUM PEROXIDE		70	X	O	X	X			X		O	O	X	O	O	O	O	O
SODIUM PHOSPHATE		200						O				O	X	O	O	X	O	O
SODIUM PHOSPHATE		70	O	O	O	O	O				O	O	X	O	O	X	O	O
SODIUM SILICATE		70	O	O	O						O	O	O	O	O	O	O	O
SODIUM SULFATE		70	O	O	O	O	O	O	O		O	O	O		O	O	O	O
SODIUM SULFIDE		70	O	O	O						O	X		O	O	O	O	O
SODIUM TETRABORATE																		
SODIUM THIOCYANATE		150	O										O	O	O	O	O	
SODIUM THIOCYANATE		70	O	O	O			O			O	O		O	O	O	O	
SODIUM THIOSULFATE		70	O	O	O	O					O	O	X	O	O	O	O	O
SODIUM TRIPHOSPHATE		100		O							O					O	O	
SOYBEAN OIL		200	O		O			O	O	O	X		O	O	O	O	O	
SOYBEAN OIL		100	O	O	O			O	O	O	X		O	O	O	O	O	
STANNIC CHLORIDE	5%	70	O	O	O	O	O	O	O		O	O	X	X		X	X	O
STANNOUS CHLORIDE	5%	70	O	O	O	O	O	O	O		O	X	X	O	X	X	O	O
STARCH		70	O	O	O						O		O	O	X	O	O	

The Premier Source for Filtration and Separation Products



## MATERIALS SELECTION GUIDE

CHEMICALS	CONCENTRATE	TEMP deg F	MEDIA							CORES				VESSELS				
			COTTON	POLYPROPYLENE	RAYON	POLYESTER	NYLON	ACRYLIC	MODACRYLIC	FIBERGLASS	POLYPROPYLENE	TIN	304 S.S.	316 S.S.	CARBON STEEL	304 S.S.	316 S.S.	POLYPROPYLENE
STEAM		220	0		0	0	0	X	X		0	0	0	0	0	0	0	
STEARATE		200	0		0		0	0	0		0	0	0	0	0	0	0	
STEARATE		120	0	0	0		0	0	0		0	0	0	0	0	0	0	0
STEARIC ACID		200					X	0	0	0	0	X	0	0	X	0	0	0
STEARIC ACID		100	0	0	0		X	0	0	0	0	X	0	0	X	0	0	0
STODDARD SOLVENT		70	0	0	0	0	0	0			0	0	0	0	0	0	0	0
STRONTIUM CARBONATE		120		0							0							
STYRENE LIQUID		250	0	X	0			0			X	0	0	0	0	0	0	0
SUCROSE SOLUTIONS		250	0	0	0			0		X		0	0	0	0	0	0	0
SUCROSE SOLUTIONS		120	0	0	0			0		X	0		0	0	0	0	0	0
SUGAR LIQUORS		250	0		0			0		X		0	0		0	0	0	0
SUGAR LIQUORS		120	0	0	0			0		X	0		0	0	0	0	0	0
SULFAMIC ACID	10%	250		0							0				X		0	
SULFATE LIQUORS		70	X	0	X		X	X	X	0	0	X			X	X	0	
SULFUR		120		0							0	0	X	0	X	0	0	
SULFUR CHLORIDE		70		0							0	0	X	0	0			
SULFUR CHLORIDE																		
SULFUR DIOXIDE (DRY)		200	X		X		X	0	0	0				0		0	0	
SULFUR DIOXIDE (DRY)		120	X	0	X		X	0	0	0	0	0	0	0	0	0	0	0
SULFUR TRIOXIDE (DRY)		200	X		X		X	0	0	0			0	0	0	0	0	
SULFUR TRIOXIDE (DRY)		120	X	0	X		X	0	0	0	0	0	0	0	0	0	0	0
SULFURIC ACID	5%	250	X	X	X		X				0	X	X	0	X	X	X	
SULFURIC ACID	25%																	
SULFURIC ACID		100	0	0	0	0	X	0	0	0	0	X	0	0	X	0	0	0
SULFURIC ACID	10%	250	X	X	X			X			X	X	X	0	X	X	X	
SULFURIC ACID	50%	250	X		X		X	X		0	X	X	X	X	X	X	X	
SULFURIC ACID	60%																	
SULFURIC ACID	75%																	
SULFURIC ACID	95%																	
SULFURIC ACID	96%	250	X		X	X	X	X	X	0		X	0	0	0		0	
SULFURIC ACID		70	X	0	X	X	X	X	0	0	X	0	0	0	0	0	0	0
SULFUROUS ACID	5%	100	0	0	0			0			0	X	0	X	X	X	X	
SULFUROUS ACID	100%	250					X	0	0	0	X		X	X	X	X	X	
SULFUROUS ACID		120		0			X	0	0	0	0	X	0	X	X	X	X	
TALLOW (MOLTEN)		120	X	0	X						0				0	0	0	
TANNIC ACID	10%	140	0		0			0	0	0		X	0	0	X	0	0	
TANNIC ACID		70	0	0	0	0	0	0	0	0	0	X	0	0	X	0	0	0
TAR OIL		120	0	0	0						0	0	0		0	0	0	
TARTARIC ACID		250			0						0	X		0			0	
TARTARIC ACID		70	0	0	0						0	0	X	0	0	0	0	
TERPENES																		
TERTIARY BUTYL ALCOHOL																		
TETRACHLORETHYLENE (DRY)		200	0		0		0	0		0		0	0	0	0	0	0	
TETRACHLORETHYLENE (DRY)		70	0	0	0		0	0	0	0	0	0	0	0	0	0	0	
TETRACHLOROETHANE		70	0	0	0	0	0	0	0	0		0	0		0	0	0	
TETRAETHYL LEAD		120	0	0							0			0	X	0	0	
TETRAETHYLENE GLYCOL (TEG)			0	0	0	70	70			0					0	0	0	0
TETRAHYDROFURAN		250	0		0			X	X	0					X			
TETRAHYDROFURAN		70	0	0	0		0	X	X	0	0				X			0
TETRAHYDRONAPHTHALENE			0	X	0	X	0			0					0	0		X
TIN ACID		70		0							0		0				0	0
TIN CYANIDE		100	0	0							0			0		0	0	
TIN FLUOBORATE		100		0						0		0	0		0	0	0	
TOLUENE		250	0		0		0	0	X	0		0	0	0	0	0	0	0
TOLUENE		70	0	0	0	0	0	0	X	0	0	0	0	0	0	0	0	0

*The Premier Source for Filtration and Separation Products*



# MATERIALS SELECTION GUIDE

CHEMICALS	CONCENTRATE	TEMP deg F	MEDIA								CORES				VESSELS			
			COTTON	POLYPROPYLENE	RAYON	POLYESTER	NYLON	ACRYLIC	MODACRYLIC	FIBERGLASS	POLYPROPYLENE	TIN	304 S.S.	316 S.S.	CARBON STEEL	304 S.S.	316 S.S.	POLYPROPYLENE
TRANSFORMER OIL		70	0	0	0					0	0	0	0	0	0	0	0	0
TRIALLYL PHOSPHATE						70	0									0	0	0
TRIARYL PHOSPHATE					0					0					0	0	0	0
TRIBUTYL PHOSPHATE				0	0					0					0	0	0	0
TRICHLOROACETIC ACID																		
TRICHLOROETHANE																		
TRICHLOROETHYLENE (DRY)		250	0	X	0			0	X	0	X	0	0	0	0	0	0	X
TRICHLOROETHYLENE (DRY)		70	0	X	0	0	0	0	X	0	X	0	0	0	0	0	0	X
TRICHLOROPROPANE																		
TRIETHANOL AMINE		70	0	0	0						0	0	0	0	0	0	0	
TRIETHYLAMINE																		
TRIETHYLENE GLYCOL (TEG)			0	0			0								0	0	0	0
TRIPHENYLAMINE		120		0						0								
TRISODIUM PHOSPHATE		70	0	0	0	0	0	0		0		0	0	0	0	0	0	0
TUNG OIL		70	0	0							0	0	0	0	0	0	0	0
TURPENTINE		250	0		0		0	0		0		0	0	0	0	0	0	
TURPENTINE		70	0	0	0	0	0	0	0	0	0	0	0	0	0	0	0	0
UREA (CARBAMIDE)				0	0	0	0			0					0	0	0	0
UREA FORMALDEHYDE RESINS		70	0		0						0				0	0	0	0
VANILLA EXTRACT		200	0		0					X			0	0		0	0	
VANILLA EXTRACT		120	0	0	0					X	0		0	0		0	0	
VARNISH		200	0	X	0		0	0	X	0	X	0	0	0	0	0	0	X
VEGETABLE JUICES			0	0	X	X	0			X					X	0	0	0
VEGETABLES		200	0		0		X		X	X		0	0	0	0	0	0	
VEGETABLES		100	0	0	0		X		X	X	0	0	0	0	0	0	0	0
VINEGAR		100	0	0	0		X		X	X	0	X	0	0	X	0	0	
VINYL CHLORIDE		120	X	0	0			0							0	0	0	
WATER (ACID)		120	0	0							0	X			X	0	0	
WATER (ALKALINE)		120	0	0							0	X				0	0	
WATER (FRESH)		200	0		0	0	0	0	0			X	0	0	0	0	0	
WATER (FRESH)		120	0	0	0	0	0	0	0		0	0	0	0	0	0	0	0
WATER (SALT)		200	0	0	0	0	0	0	0		X	X	X	X	X	X	X	
WATER (SALT)		120	0	0	0	0	0	0	0		0	X	X	X	X	X	X	0
WATER DISTILLED			X	0	0	X	0			X					X	0	0	0
WATER, DELONIZED			X	0	0	0	0								X	X	0	
WAXES		250	0		0							0	0	0	0	0	0	
WAXES		70	0	0	0							0	0	0	0	0	0	
WHALE OIL		120	0	0							0					0	0	
WHISKEY		70	0		0				X						X	0	0	0
WHITE WATER			X	X	X				X		X	X	0	0		0	0	
WINE		70	0		0				X						X	0	0	0
XYLENE		250	0	X	0	0	0	0	X	0	X	0	0	0	0	0	0	
XYLOC		250	0	X	0	0	0	0	X	0	X	0	0	0	0	0	0	
ZINC BROMIDE		250					X	0		0					0			
ZINC BROMIDE	3%	120	0	0	0		X	0		0	0			0			0	
ZINC CHLORIDE	2%	120	0	0	0			0			0	X	X	0	0		0	
ZINC CYANIDE		100	0	0	0						0			0	0	0	0	0
ZINC CYANIDE		200			X		0	X	0	X								
ZINC CYANIDE		120		0	X		0	X	0	X	0	X	0	0	X	0	0	
ZINC FLUOBORATE		130							0					0				0
ZINC HYDROXIDE		120		0							0				0	0	0	
ZINC SULFATE		250						0		0	X	0	0	X	0	0	0	
ZINC SULFATE	3%	120	0	0	0			0		0	X	0	0	X	0	0	0	

The Premier Source for Filtration and Separation Products





**FISCHER-ROBERTSON, INC.**  
FILTRATION & SEPARATION

(513) 860-3445 | [Sales@fischer-robertson.com](mailto:Sales@fischer-robertson.com)