

Fischer-Robertson, Inc.

3890 Symmes Road
 Hamilton, OH 45015
 Ph 513-860-3445 Fx 513-860-4744
www.fischer-robertson.com

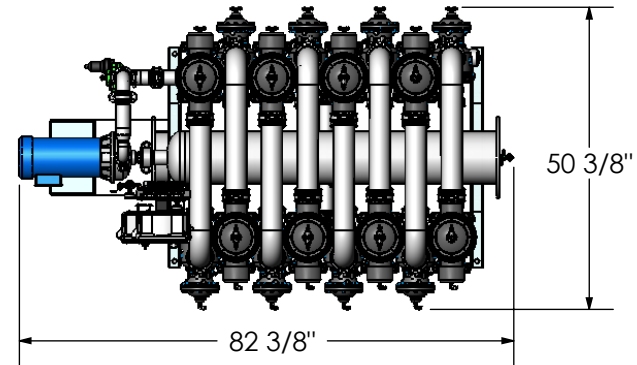
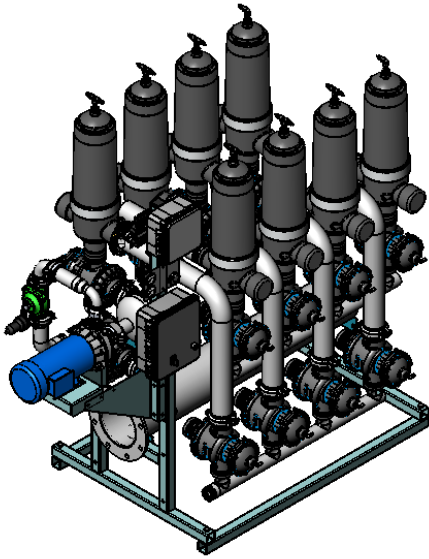

Pneumatic Valve Manifold

ATD-3NV-200 Filter
 (200 Micron)
 Polyamide Housing
 8 Places

Valve, Pressure
 Reducing

3x3 Angle Flow Valve
 Polyamide Housing
 16 Places

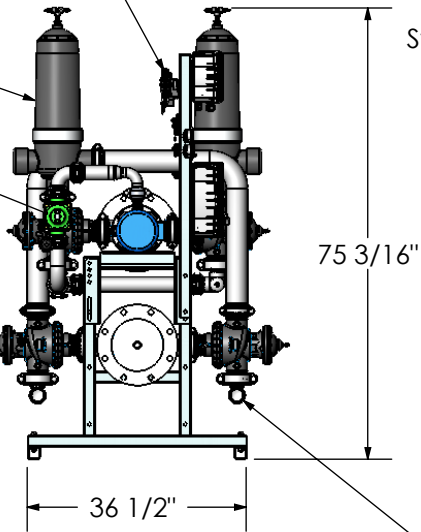

2" NPT(m) Backflush Manifold - 2 Places
 Connections may be made at either end.
 (2 threaded pipe caps are supplied)

Controller

Air Connection

System Power Feed
 & Motor Starter

316 Stainless
 Booster Pump
 5 HP

INLET, 8"
 150 Lb. Flange
 Stainless Steel

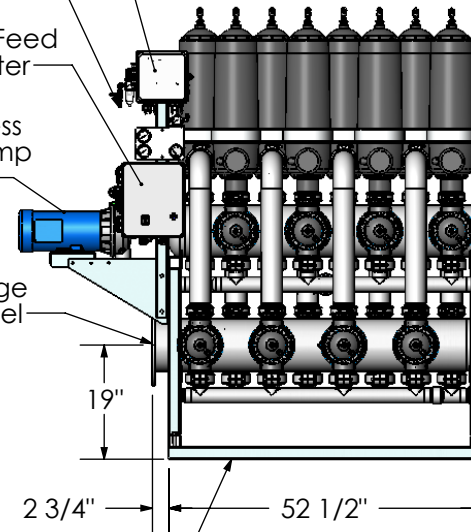

OUTLET, 8"
 150 Lb. Flange
 304 Stainless

Drain Valve with
 Hose Connection

Frame/Skid
 304 Stainless

SYSTEM REQUIREMENTS

Electrical: 230VAC/1 Phase/60Hz/21A
 Air Supply: 2 CFM@80-100 PSI
 Water Supply Pressure: 25-80 PSI
 Water Flow Rate: 100-800 GPM
 Dry Weight: 1250 Lbs.

PRODUCT SPECIFICATION

MILLER-LEAMAN INC.

800 Orange Ave. Daytona Beach FL 32114

| | | |
|-----------|-----------|---------|
| DRAWN | J. Larsen | 11/4/08 |
| CHECKED | | |
| ENG APPR. | | |
| MKT APPR. | | |

TITLE
 Automatic Turbo-Disc
 Filter Skid System
 B1H-ATD3(8)x8-200M-A-MOD1