

Fischer-Robertson, Inc.

3890 Symmes Road
 Hamilton, OH 45015
 Ph 513-860-3445 Fx 513-860-4744
www.fischer-robertson.com

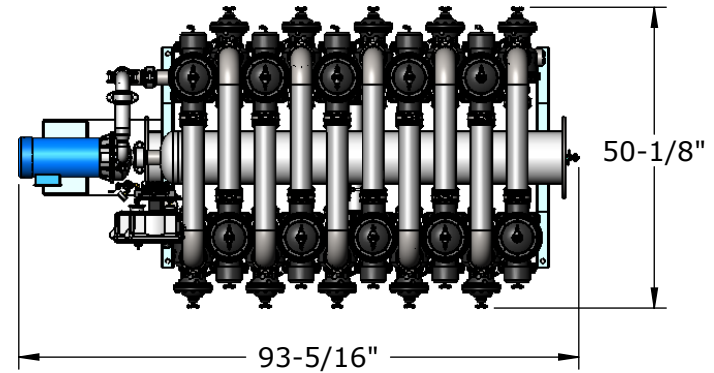
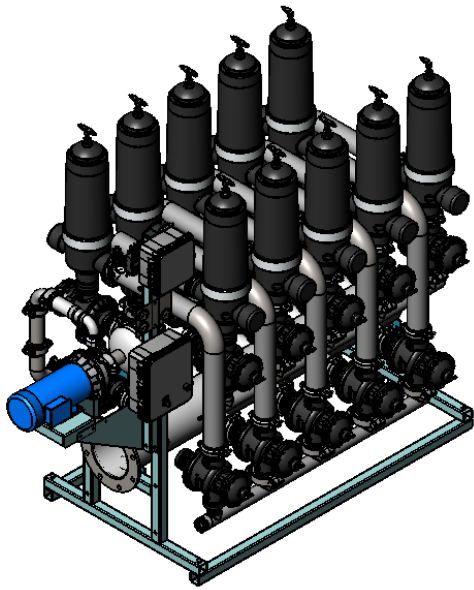

Pneumatic Valve Manifold

ATD-3NV-130 Filter
 (130 Micron)
 Polyamide Housing
 10 Places

3x3 Angle Flow Valve
 Polyamide Housing
 20 Places

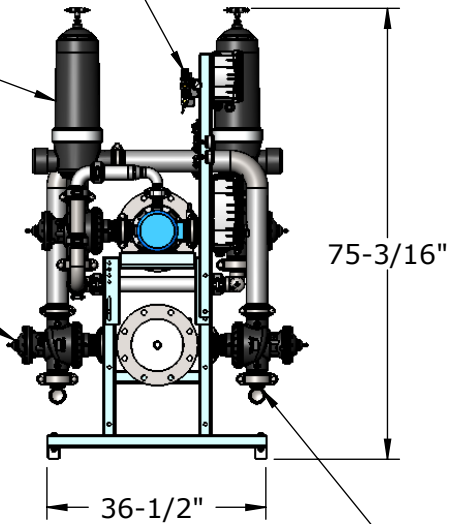

2" NPT(m) Backflush Manifold - 2 Places
 Connections may be made at either end.
 (2 threaded pipe caps are supplied)

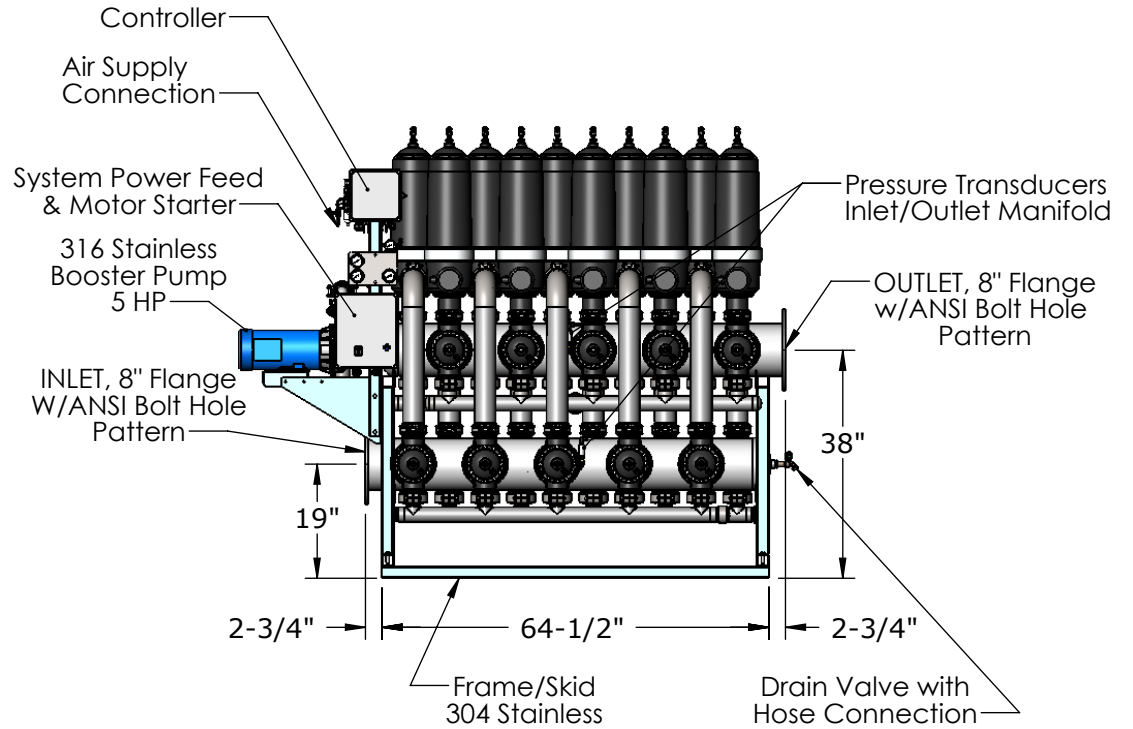

PRODUCT SPECIFICATION

MILLER LEAMAN INC

800 Orange Ave. Daytona Beach FL 32114

DRAWN	J. Larsen	1/10/11
CHECKED		
ENG APPR.		
MKT APPR.		
SHEET 1 of 1	Ref: ML21063-10A	Rev: A

SYSTEM REQUIREMENTS:
 Electrical: 460VAC/3Ph/60Hz/8A
 Air Supply: 4CFM @ 80-100 PSI
 Water Supply @ Inlet: 30-75 PSI
 Water Flow Rate: 1000 GPM Max.
 Dry Weight: 1425 lbs
 Max Pressure: 125 PSI. Max Temperature: 140°F

TITLE:
**AUTOMATIC TURBO DISC
 FILTER SKID SYSTEM
 B2-ATD3(10)x8-130M-A**