

Audible Alarm

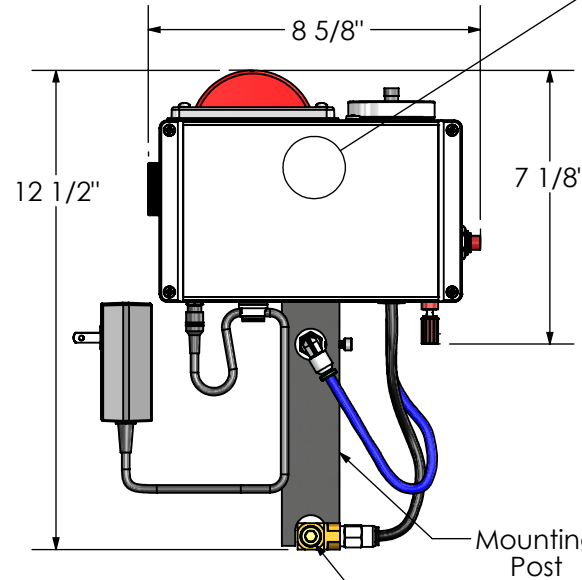

Alarm Reset Switch

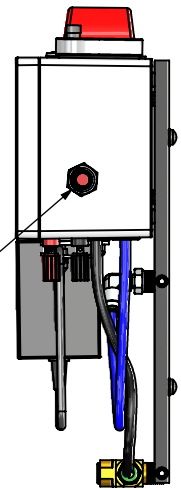

**SPECIFICATIONS:**

Maximum Static Pressure: 120 psi @ 73 deg.F  
 Maximum Readable PD: 15 psid  
 PD Limit: 30 psid  
 Power Supply: Plug-in AC/DC 25W Switching -  
 Input Power: 120VAC Nominal  
 (100-240VAC, 50/60Hz, 0.7A)  
 Output Power: 12VDC Nominal  
 (11-13VDC, 1.92-2.27A)  
 Output Power: 12VDC @ 1.5 Amps (ATF Power)  
 Alarm Setpoint: DP Gauge Knob Adjustable  
 Alarm Outputs -  
 Visual: Flashing Red Dome Light  
 Audible: Alternating Piezo-Electric Sounder (95dB)  
 Aux. Contact: Jumper Configurable Signal Output  
 available for Customer Connection at Red &  
 Black Binding Posts - Maximum Load is 0.5 Amps.  
 Alarm Reset: Side Mounted Pushbutton

Power connection  
to Pressure Differential  
Alarm

1/4" NPT Plug - Removeable for Customer  
Pressure Gauge installation.

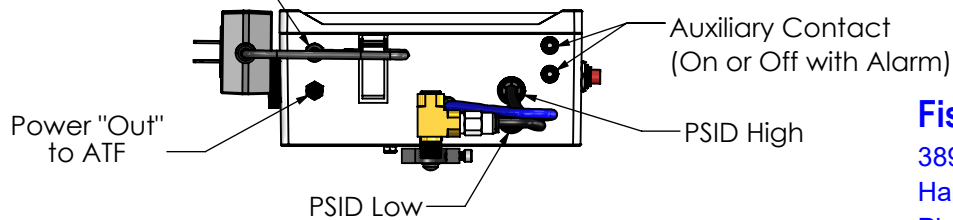

**Fischer-Robertson, Inc.**  
 3890 Symmes Road  
 Hamilton, OH 45015  
 Ph 513-860-3445 Fx 513-860-4744  
[www.fischer-robertson.com](http://www.fischer-robertson.com)

**PRODUCT SPECIFICATION**

**MILLER LEAMAN** INC

800 Orange Ave. Daytona Beach FL 32114

DRAWN	J. Larsen	10/10/05
CHECKED		
ENG APPR.		
MKT APPR.		
SHEET 1 of 1	Ref: ML20561	Rev: F

TITLE:	Pressure Differential Alarm Package # PDA
--------	---