

# Demi HSA ⊕ Z Style Filter Housing

- sanitary air / gas



- Flow efficient range of air / gas housings
- Available in 4 different housing classes: Standard (CE), ATEX, High Pressure & Oxygen Service
- Sanitary and sanitary electropolished surface finishes available
- A choice of connections, vents, drains, gaskets & surface finishes
- Parker domnick hunter 'Z' location

(PLUS product only - no STANDARD range)



## Specification

### Materials of Construction

- Housing: 316L Stainless Steel
- Body Seal: EPDM FDA  
PTFE FDA  
Silicone FDA  
Viton™/FKM FDA
- Vent / Drain Seal: PTFE FDA

### Surface Finish Options

- Sanitary
  - Internal: Polished 0.4 µm Ra (16 µIn Ra)
  - External: Polished 0.25 µm Ra (10 µIn Ra)
- Sanitary Electropolished
  - Internal: Polished 0.4 µm Ra (16 µIn Ra) and Electropolished
  - External: Polished 0.25 µm Ra (10 µIn Ra)

### Welding

All assembly welds are full penetration. All welds are crevice and undercut free. Weld finish & detail drawings available upon request.

### Directives

Housings designed in accordance with the European Council Pressure Equipment Directive (PED). ATEX (where applicable).

### Design Basis

ASME VIII Division 1.

### Approvals

EAC 010-2011, (No. TC N RU D-GB. AИ01.B.00511)  
Approval type: Import Certificate, TR CU Pressure Equipment (available on request)



ATEX Working Condition PED			Maximum Pressure	
Fluid Group	State	Temperature	01A	01B
Non Dangerous & Dangerous	Gas / Vapour	135 °C [275 °F]	10 barg (145 psig)	10 barg (145 psig)
PED Conformity Assessment Category			SEP	SEP
Volume (litres)			0.75	0.50

CE Working Condition PED			Maximum Pressure	
Fluid Group	State	Temperature	01A	01B
Non Dangerous & Dangerous	Gas / Vapour	150 °C [302 °F]	10 barg (145 psig)	10 barg (145 psig)
PED Conformity Assessment Category			SEP	SEP
Volume (litres)			0.75	0.50

High Pressure Working Condition PED			Maximum Pressure	
Fluid Group	State	Temperature	01A	01B
Non Dangerous	Gas / Vapour	205 °C [401 °F]	16 barg (232 psig)	16 barg (232 psig)
PED Conformity Assessment Category			SEP	SEP
Volume (litres)			0.75	0.50

Oxygen Service Working Condition PED			Maximum Pressure	
Fluid Group	State	Temperature	01A	01B
Dangerous	Gas / Vapour	150 °C [302 °F]	10 barg (145 psig)	10 barg (145 psig)
PED Conformity Assessment Category			SEP	SEP
Volume (litres)			0.75	0.50

Note: All housings are full vacuum rated.

## Physical Characteristics

Bowl Height	Dimensions (mm)					Typical Weight (kg)
	A'	B'	C'	C		
A Size 5" (125 mm)	106	149	172	295	177	1.5
B Size 2 1/2" (65 mm)	106	149	172	240	122	1.4

Dimensions are based on illustration shown.  
For accurate dimensions, please contact Parker domnick hunter.

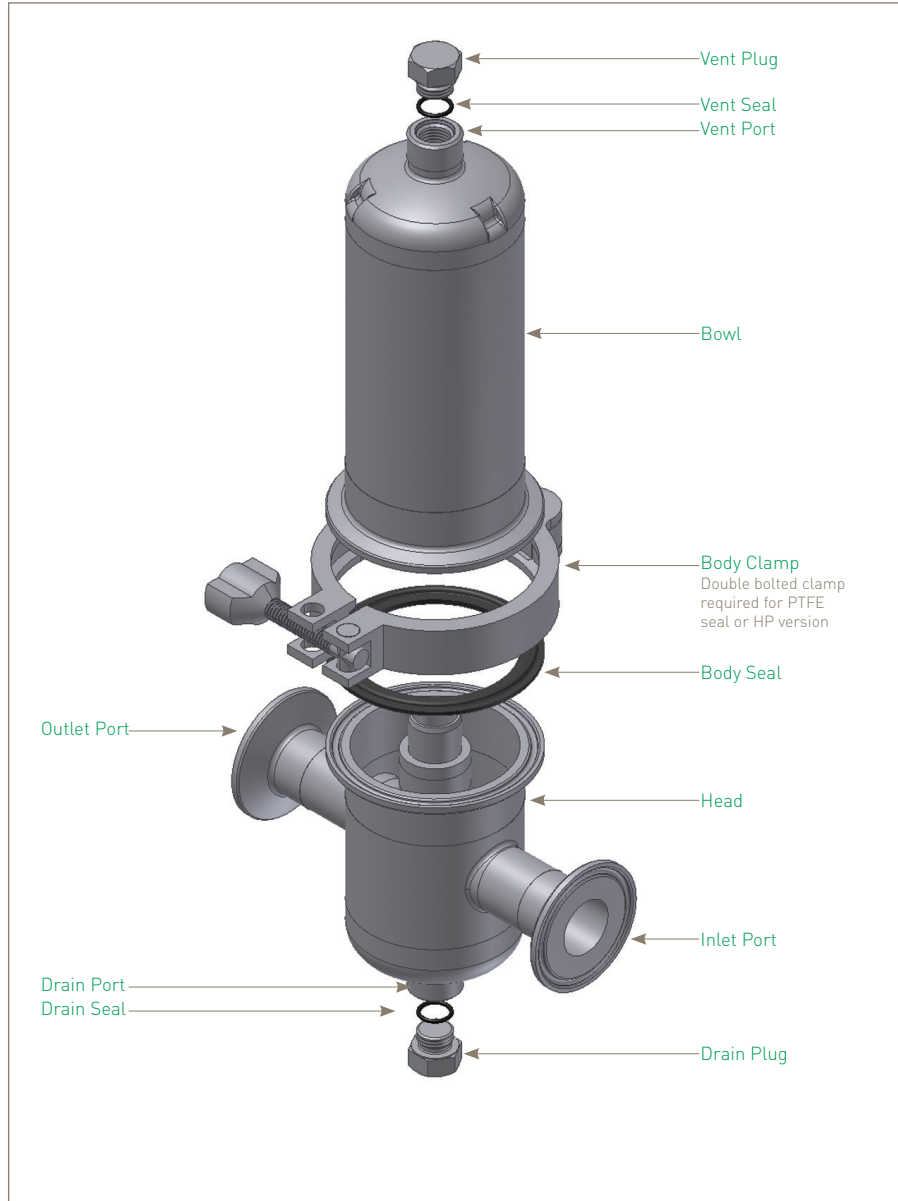
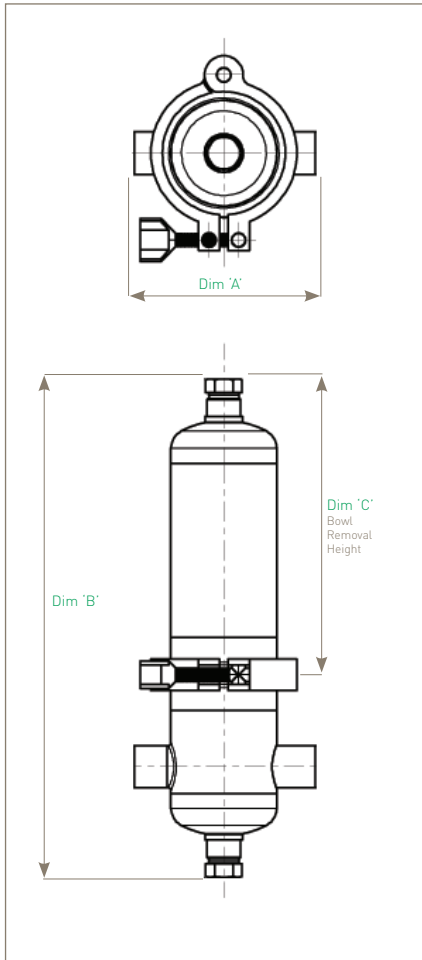

## Ordering Information

Code   Vessel Class	Code   Length (Nominal)	Code   Connection Size	Code   Standard	Code   Cartridge	Code   Seal	Code   Vent	Code   Drain
CE Standard AT ATEX HP High Pressure OX Oxygen Service	A 5" (125 mm) B 2 1/2" (65 mm)	B 1"	B BSPP (F) N NPT (F) T Tri-Clamp® W 25.4 X 1.6mm Weld end	Z 116	E EPDM P* PTFE S Silicone V Viton™/FKM	B 1/4" BSPP (G1/4") N 1/4" NPT	B 1/4" BSPP (G1/4") N 1/4" NPT

\* Double bolted clamp required

Code   Surface Finish	Internal	External
B Sanitary	0.4 µm	0.25 µm
P Sanitary Electropolished	0.4 µm EP	0.25 µm

Code   Tagged	Yes	No
T	Yes	No
X	No	Yes

For Tagged Options customer identification numbers required at time of ordering



Viton™ is a registered trademark of DuPont Performance Elastomers L.L.C.  
Tri-Clamp® is a registered trademark of Alfa-Laval, Inc.  
Note: All Tri-Clamp® Connections conform to BS4825 Pt.3

Parker domnick hunter has a continuous policy of product development and although the Company reserves the right to change specifications, it attempts to keep customers informed of any alterations. This publication is for general information only and customers are requested to contact our Process Filtration Sales Department for detailed information and advice on a products suitability for specific applications. All products are sold subject to the company's Standard conditions of sale.